



***BEACH
COMMUNITY DEVELOPMENT DISTRICT***

Advanced Meeting Package

Regular Meeting

***Monday
November 20, 2023
6:00 p.m.***

***Location:
12788 Meritage Blvd.,
Jacksonville, FL 32246***

Note: The Advanced Meeting Package is a working document and thus all materials are considered DRAFTS prior to presentation and Board acceptance, approval or adoption.

Beach Community Development District

250 International Parkway, Suite 208
Lake Mary FL 32746
321-263-0132

Board of Supervisors
Beach Community Development District

Dear Board Members:

The Regular Meeting of the Board of Supervisors of the Beach Community Development District is scheduled for **Monday, November 20, 2023, at 6:00 p.m.** at the **12788 Meritage Blvd., Jacksonville, FL 32246**

An advanced copy of the agenda for the meeting is attached along with associated documentation for your review and consideration. Any additional support material will be distributed at the meeting.

Should you have any questions regarding the agenda, please contact me at (321) 263-0132 X-193 or dmcinnes@vestapropertyservices.com. We look forward to seeing you at the meeting.

Sincerely,

David McInnes

David McInnes
District Manager

Cc: Attorney
Engineer
District Records

District: **BEACH COMMUNITY DEVELOPMENT DISTRICT**

Date of Meeting: Monday, November 20, 2023

Time: 6:00 PM

Location: 12788 Meritage Blvd.,
Jacksonville, FL 32246

Call-in Number: +1 (929) 205-6099

Meeting ID: 7055714830#

Revised Agenda

- I. Roll Call**
- II. Pledge of Allegiance**
- III. Audience Comments** – (limited to 3 minutes per individual for agenda items)
- IV. Presentation of Proof of Publication(s)** [Exhibit 1](#)
- V. Vendor Reports**
 - A. Vesta Property Services
 - 1. Lifestyle Management Report [Exhibit 2](#)
 - 2. Field Management Report [Exhibit 3](#)
 - B. Advanced Security Specialist
 - C. Tree Amigos
- VI. Consent Agenda**
 - A. **Consideration for Approval – The Minutes of the Board of Supervisors Regular Meeting Held on October 16, 2023** [Exhibit 4](#)
 - B. Consideration for Acceptance – The Revised September 2023 Unaudited Financial Statements [Exhibit 5](#)
 - C. Consideration for Acceptance – The October 2023 Unaudited Financial Statements [Exhibit 6](#)
- VII. Business Items**
 - A. Consideration & Adoption of **Resolution 2024-02**, Tree Removal on CDD ROW – *To Be Distributed*
 - B. Consideration of Charles Aquatics Amenity Center Fountain Repair Proposal Options [Exhibit 7](#)
 - C. Consideration of Amenity Center Fountain Replacement Proposal Options
 - 1. Charles Aquatics [Exhibit 8](#)
 - 2. Lake Doctors – *previously presented* [Exhibit 9](#)
 - D. Consideration of Lucas Tree Dead Tree Cutting Behind Residents on Ostia Circle Proposal [Exhibit 10](#)

VII. Business Items – continued

- E. Consideration of Acceptance of Parcels from Developer
 - 1. Proposed Parcel #1 [Exhibit 11](#)
 - 2. Proposed Parcel #2 [Exhibit 12](#)
 - 3. Proposed Parcel #3 [Exhibit 13](#)
 - 4. Proposed Parcel #4 [Exhibit 14](#)
 - 5. Proposed Parcel #5 [Exhibit 15](#)
 - 6. Parcel Numbers 165284-6050 & 167067-0475 [Exhibit 16](#)
- F. Consideration of All Weather Contractors Sidewalk Repair Proposals
 - 1. Savona Ct. [Exhibit 17](#)
 - 2. 1st Phase [Exhibit 18](#)
- G. Consideration of Holiday Lighting Proposal – *To Be Distributed*
- H. Consideration & Adoption of **Resolution 2023-04**, 2024 General Election [Exhibit 19](#)

VIII. Discussion Topics

- A. Discipline Process

IX. Staff Reports

- A. District Counsel
 - 1. Report on Research of Tree Issue
- B. District Manager
 - 1. Resident(s) Subject Disciplinary Action
 - 2. Complaint & Incident Management Tracker
 - 3. Action Item Report [Exhibit 20](#)
 - 4. Meeting Matrix [Exhibit 21](#)
 - 5. Memo to Board Regarding Items of Consensus from the 10/25/23 Workshop [Exhibit 22](#)
 - 6. Request for Clarification
 - a. Tree Stakes
 - b. Pressure Washing of Beach Blvd. Monument Fountain
- C. District Engineer

X. Supervisors' Requests

XI. Audience Comments (*limited to 3 minutes per individual for non-agenda items*)

XII. Action Items Summary

XIII. Meeting Matrix Summary

XIV. Next Meeting Quorum Check: December 18, 6:00 PM

Elena Korsakova	<input type="checkbox"/> IN PERSON	<input type="checkbox"/> REMOTE	<input type="checkbox"/> NO
Chance Wedderburn	<input type="checkbox"/> IN PERSON	<input type="checkbox"/> REMOTE	<input type="checkbox"/> NO
Sheila S. Papelbon	<input type="checkbox"/> IN PERSON	<input type="checkbox"/> REMOTE	<input type="checkbox"/> NO
Matt Calderaro	<input type="checkbox"/> IN PERSON	<input type="checkbox"/> REMOTE	<input type="checkbox"/> NO
Robert Renn	<input type="checkbox"/> IN PERSON	<input type="checkbox"/> REMOTE	<input type="checkbox"/> NO

XV. Adjournment

EXHIBIT 1

STATE OF FLORIDA,

S.S.

COUNTY OF DUVAL,

Before the undersigned authority personally appeared Nichol Stringer, who on oath says that she is the Publisher's Representative of the JACKSONVILLE DAILY RECORD, a weekly newspaper published at Jacksonville, in Duval County, Florida; that the attached copy of advertisement, being a Notice of Board of Supervisors Workshop

in the matter of Beach Community Development District

in the Court, was published in said newspaper by print in the issues of 11/9/23.

Affiant further says that the JACKSONVILLE DAILY RECORD complies with all legal requirements for publication in Chapter 50, Florida Statutes.

*This notice was published on both jaxdailyrecord.com and floridapublicnotices.com.



Nichol Stringer

Sworn to and subscribed before me this 9th day of November, 2023 by Nichol Stringer who is personally known to me.

**BEACH COMMUNITY
DEVELOPMENT DISTRICT
NOTICE OF BOARD
OF SUPERVISORS
REGULAR MEETING**

Notice is hereby given that a regular meeting of the Board of Supervisors of the Beach Community Development District (the "District") will be held on Monday, November 20, 2023, at 6:00 p.m. at 12788 Meritage Blvd. Jacksonville, FL 32246. The purpose of the meeting is to discuss any topics presented to the board for consideration.

Copies of the agenda may be obtained from the District Manager, Vesta District Services, 250 International Parkway, Suite 208, Lake Mary, Florida 32746, Telephone (321) 263-0132, Ext. 193.

The meeting is open to the public and will be conducted in accordance with the provisions of Florida law for community development districts. The meeting may be continued in progress without additional notice to a date, time, and place to be specified on the record at the meeting. There may be occasions when Staff and/or Supervisors may participate by speaker telephone.

Pursuant to provisions of the Americans with Disabilities Act, any person requiring special accommodations to participate in the meeting is asked to advise the District Manager's office at least forty-eight (48) hours before the meeting by contacting the District Manager at (321) 263-0132, Ext. 193. If you are hearing or speech impaired, please contact the Florida Relay Service at 711, for assistance in contacting the District Manager's office.

A person who decides to appeal any decision made at the meeting, with respect to any matter considered at the meeting, is advised that a record of the proceedings is needed and that accordingly, the person may need to ensure that a verbatim record of the proceedings is made, including the testimony and evidence upon which the appeal is to be based.

**Beach Community
Development District**
David McInnes, District Manager
(321) 263-0132, Ext. 193
Nov. 9 00 (23-07394D)

Seal

Notary Public, State of Florida

EXHIBIT 2



TAMAYA

BETWEEN THE CITY AND THE SEA

Manager's Report

Submitted by: Oliver Ingram & Ron Zastrocky

Date of report: November 13, 2023

Spooky story time & craft hour on 10/08/23 @ Tamaya Hall



Spooky Story Time & Craft on 10/08/23 @ Tamaya Hall

Cost: Book and backdrop for grandparents day \$45.00

Drinks and Snacks \$123.48 Total Cost: \$168.48

Total in attendance 16 children and adults

Family Halloween on 10/14/23@ Tamaya field from 12:00 pm - 2:30 pm



Family Halloween at Tamaya Field
Three bounce houses and DJ doing fun games with the kids and family. Over a hundred of people attended. Total price is combined with Oktoberfest please see below.

Oktoberfest evening event on 10/14/23@ Tamaya Hall from 6:00 pm 9:00 pm



Total Cost for Family Halloween & Oktoberfest

Catering: Food truck,
bartenders, DJ, bounce
houses, decorations
Total for event \$5,424.00
Collected \$640 event fee

Total combined attending for both Family Halloween & Oktoberfest was between 135 - 140 people.

Bourbon & Cigars event on 11/03/23 Tamaya Hall & Palm Court from 6:00 pm to 9:00 pm



Total cost for Bourbon & Cigars Event

JAXDOM USA INC. Cigars Roller Entertainment Event \$450.00

Appetizers \$233.22

Bourbon \$230.00

Total \$913.22

80 people in attendance

NOVEMBER PROGRAMMING:

- **Strength, Balance, and Flexibility With Emma**- Has resumed for October.
- **Zumba with Tangie B**- every Thursday 6:30- 7:30 PM in group fitness room.

SOCIAL CLUBS:

- Current clubs: Lunch bunch, Bible study, Bunco, Garden Club, Tamaya Chapter Chatters
- New Scrap booking club started by Paula Pesci Rodriquez.

AMENITY CENTER:

- Released November Calendar of events and newsletter.
- All Weather Engineers started the window installation at the gym on November 1st.
- New Cardio Equipment for the Gym will be installed December 7th.

TEK Control:

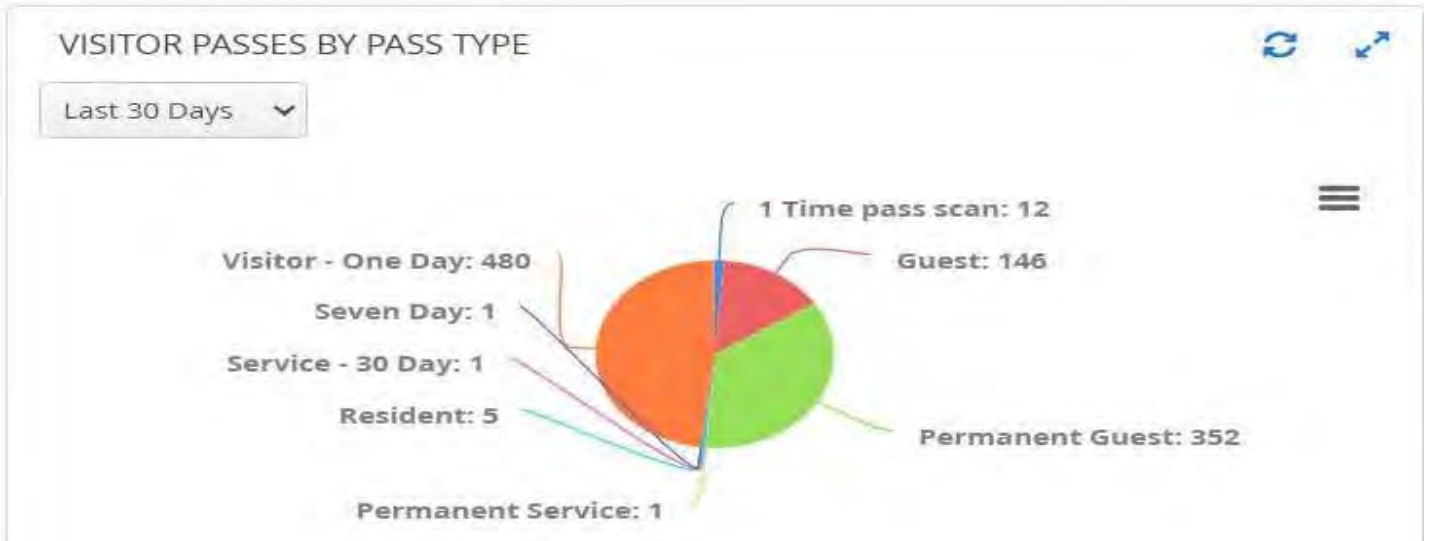
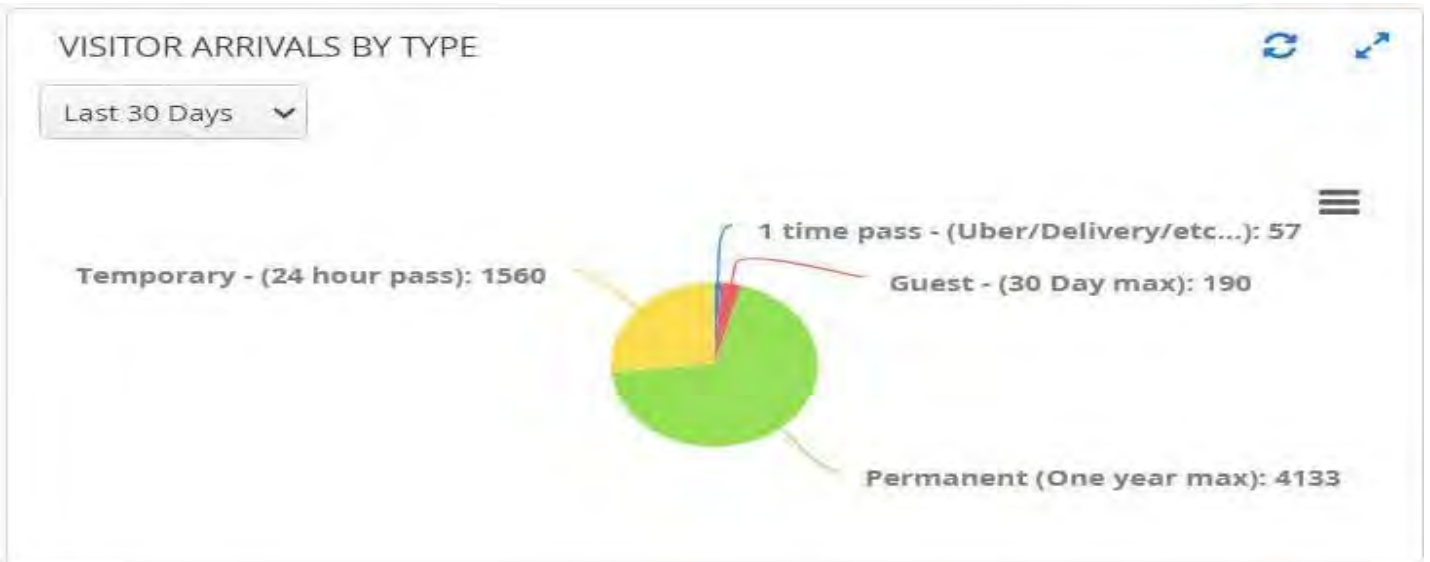

VISITOR ARR[VALS BY DAY

Last 30 Days

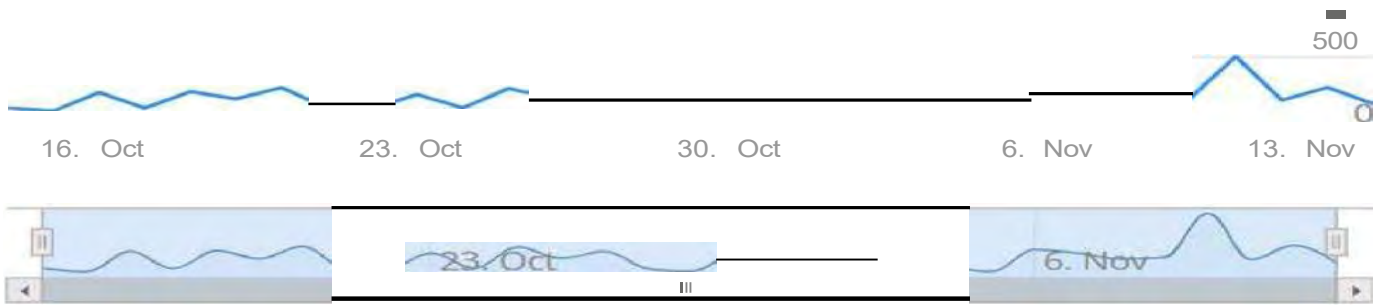

VfSITORS ADMITTED BY OFFICER

Last 30 Days



HOSTLOGINSOURCE



DAILYVISITORACTIVITY

Visitors Added By Officers	39
VisitorsAdded By Management	0
VisitorsAdded ByHosts	24
Total Passes Issued	15
TotalAdmitted	156

VISITORARRIVALSTATISTICS

Last 30 Days

191.61 **176.0**

Average Per Day Average Process Time (seconds)

VISITORARRIVALSBY HOUR

Last 30 Days



EXHIBIT 3



Field Operations Managers' Report

Date of report: 11-13-2023

Submitted by: Ron Zastrocky

Field Operations Report

Landscape update

Beach CDD: Monthly Report

October 2023

Fungus/Pest/Fertilizer: Target for this month's application was to improve the overall health, color, and growth of the turf. Insecticides and post emergent herbicides were applied for turf destroying insects and weeds, such as sedges and broadleaf weeds.

Manganese Sulfate @ 3lbs per acre

Ferrous Sulfate @ 10lbs per acre

Princep @ 64oz per acre

2, 4-D @ 8oz per acre

MSM @ .3oz per acre

Bifen @ 7oz per acre

Imidacloprid @ 26oz per acre

Maintenance: Regular weekly maintenance was serviced to all turf areas. Round-up was applied to all landscape beds inside Beach CDD. Ornamental grasses were trimmed to improve new growth. Oak trees were lifted off sidewalks and street on Meritage Blvd. Bent Water wall was sprayed with herbicide after all vegetation was removed.

Annuals: Weekly Fall maintenance was applied to all annual beds including dead heading flowers and weed pulling.

Irrigation Report: All the irrigation inside Beach CDD is properly working and has proper coverage on turf and shrubs.

Notes: As we move into the winter season we will focus on tree trimming, as well as cutting back all ornamental grasses. We hope to improve the overall look of the landscape throughout the neighborhood.

Pond update

- Completed Date: 11/2/2023 Target Pests (if applicable): Service Notes & Observations Inspected

ponds 1-9 and treated several of them for algae. Heavier algae treatment applied to pond 1. Please allow 5-7 days to see results

General Maintenance

- Pressure washed old Beach Blvd entrance



- Replaced step light by Palm Court
- Contractor started windows in fitness center office
- Replaced bulb in parking lot light
- Outside AC unit replaced for Tamaya hall
- Action item list update

9/18/2023	FOM to obtain quotes to have tree stakes removed from landscaping	10/16/2023: Tabled until 11/20 meeting. I have started to remove stakes around Amenity center
10/16/2023	FOM to send pictures of DM of Beach Fountains when Pressure Washed	On hold pending direction at 11/20 meeting.
10/16/2023	FOM to obtain a quote for fountain repair in front of Tamaya Hall and inquire about warranty	Charles Aquatics proposal in files for 11/20 meeting
10/16/2023	FOM to contact AED vendor and provide paperwork to DC for contract template	10/31: Per Wes, template not needed; sent to Chair for signature. Chair signed and waiting on install date
10/16/2023	FOM to obtain quotes for pool lighting replacement	In progress. Have price for lights and will need to get a quote for labor

<p>10/16/2023</p>	<p>FOM to obtain quotes for Tamaya Blvd. lighting and pictures of areas covered by quotes</p>	<p>In progress. Have price for lights and will need to get a quote for labor</p> 
-------------------	---	---

EXHIBIT 4

1 **MINUTES OF MEETING**

2 **BEACH**

3 **COMMUNITY DEVELOPMENT DISTRICT**

4 The Regular Meeting of the Board of Supervisors of the Beach Community Development District
5 was held on Monday, October 16, 2023 at 6:02 p.m., at 12788 Meritage Blvd., Jacksonville, Florida 32246,
6 with Zoom Conference Call available.

7 **FIRST ORDER OF BUSINESS – Roll Call**

8 Mr. McInnes called the meeting to order and conducted roll call.

9 Present and constituting a quorum were:

- | | | |
|----|-------------------|---------------------------------------|
| 10 | Matt Calderaro | Board Supervisor, Chairman |
| 11 | Robert Renn | Board Supervisor, Vice Chairman |
| 12 | Chance Wedderburn | Board Supervisor, Assistant Secretary |
| 13 | Sheila Papelbon | Board Supervisor, Assistant Secretary |
| 14 | Elena Korsakova | Board Supervisor, Assistant Secretary |

15 Also present were:

- | | | |
|----|-------------------------------|---|
| 16 | David McInnes | District Manager, Vesta District Services |
| 17 | Barry Jeskewich | District Manager, Vesta District Services |
| 18 | Wes Haber <i>(via phone)</i> | District Counsel, Kutak Rock LLP |
| 19 | Dana Harden | Regional General Manager, Vesta Property Services |
| 20 | Oliver Ingram | Amenity Manager, Vesta Property Services |
| 21 | Ron Zastrocky | Field Operations Manager, Vesta Property Services |
| 22 | Scott Wild <i>(via phone)</i> | District Engineer, ETM |
| 23 | Brittany Bell | Operations Manager, Advanced Security |
| 24 | Dave Putnam | Resident |
| 25 | Walt Repak | Resident |
| 26 | Karen Young | Resident |
| 27 | Kate Kendig | Resident |
| 28 | Daniel Thimann | Resident |

29 *The following is a summary of the discussions and actions taken at the October 16, 2023 Beach CDD Board*
30 *of Supervisors Regular Meeting. Audio for this meeting is available upon public records request.*

31 **SECOND ORDER OF BUSINESS – Pledge of Allegiance**

32 Supervisor Calderaro led all present in reciting the Pledge of Allegiance.

33 **THIRD ORDER OF BUSINESS – Audience Comments – (limited to 3 minutes per individual for agenda**
34 *items)*

35 Mr. Putnam asked for clarification on what a CDD Row was. He also asked about the District
36 Engineer’s report being presented later in the meeting and made a recommendation on a verbiage
37 change within the letter sent to property owners along Tamaya Blvd. regarding maintenance of the
38 grassy areas.

39 Mr. Repak recommended that the CDD enforce a rule regarding tree trimming along the streets that
40 the branches be trimmed to about six to seven feet above the sidewalk and ten feet above the
41 sidewalk on Meritage Blvd.

42 Ms. Young asked for clarification and specifics regarding advertising of meetings. Discussion
43 ensued.

80
81 C. Exhibit 5: Consideration for Acceptance – The September 2023 Unaudited Financial Statements
82

83 On a MOTION by Dr. Renn, SECONDED by Ms. Korsakova, WITH ALL IN FAVOR, the Board approved
84 the Consent agenda as is, for the Beach Community Development District.

85 Discussion ensued regarding whether the District had provided direction to the Trustee on the
86 investment of debt service funds being held. The Board directed the District Manager to write a
87 letter to the Trustee instructing them to invest excess funds in Florida Prime to the maximum extent
88 possible.

89 **SEVENTH ORDER OF BUSINESS – Business Items**

90 A. Exhibit 6: Consideration of Integrated Access Solutions Guest Lane Gate Arm Proposal –
91 *previously presented*
92 Supervisor Renn provided a brief explanation of the proposal. Discussion ensued.

93 On a MOTION by Dr. Renn, SECONDED by Ms. Papelbon, WITH Mr. Calderaro and Ms. Korsakova
94 voting “yea” and Mr. Wedderburn voting “nay”, the Board approved the Integrated Access Solutions Guest
95 Lane Gate Arm proposal, in an amount not-to-exceed \$8,000.00, for the Beach Community Development
96 District.

97 Discussion continued.

98 B. Exhibit 7: Consideration of AED Proposal Options - *previously presented*
99 1. American AED
100 2. HeartSmart AED

101 Supervisor Korsakova recommended that the Board consider an alternative proposal that
102 she had researched. The Board accepted Supervisor Korsakova’s recommendation of the
103 Zoll 3 AED, in the amount of \$145 per month for 36 months. Discussion ensued.

104 On a MOTION by Ms. Korsakova, SECONDED by Ms. Papelbon, WITH ALL IN FAVOR, the Board
105 approved the Zoll 3 AED proposal, in the amount of \$145 per month for 36 months, for the Beach
106 Community Development District.

107 C. Consideration & Adoption of **Resolution 2024-02**, Tree Removal on CDD ROW – *To Be*
108 *Distributed*

109 This item was tabled until the following meeting.

110 D. Exhibit 8: Consideration of 5 Star Pressure Washing Proposals

111 Discussion ensued regarding both proposals.

112 1. Old Entrance Wall & Pavers

113 On a MOTION by Mr. Calderaro, SECONDED by Ms. Korsakova, WITH ALL IN FAVOR, the Board
114 approved the 5 Star Pressure Washing proposal of the Old Entrance Wall & Pavers, in the amount of
115 \$1,050.00, for the Beach Community Development District.

116 2. Two Fountains on Beach Blvd.

117 On a MOTION by Mr. Calderaro, SECONDED by Mr. Wedderburn, WITH ALL IN FAVOR, the Board
118 approved the 5 Star Pressure Washing proposal of the Two Fountains on Beach Blvd., in the amount of
119 \$650.00, for the Beach Community Development District.

120 E. Exhibit 9: Consideration of Amenity Center Fountain Repair Proposal Options
121 Discussion ensued. This item was tabled until further notice with the direction to obtain a
122 quote for repair only with a warranty for the repair to be included.

- 123 1. Lake Doctors
- 124 2. Charles Aquatics – *To Be Distributed*

125 F. Consideration of Tree Amigos Proposals
126 1. Exhibit 10: Quote #201486 – Removal of Guava Plants Behind Basketball Court
127 Mr. Zastrocky gave a brief explanation for the proposal. Discussion ensued.

128 On a MOTION by Mr. Wedderburn, SECONDED by Mr. Calderaro, WITH ALL IN FAVOR, the Board
129 approved the Tree Amigos Quote #201486, in the amount of \$649.00, for the Beach Community
130 Development District.

- 131 2. Exhibit 11: Quote #201487 – Podocarpus Installation
132 Discussion ensued.

133 On a MOTION by Mr. Calderaro, SECONDED by Ms. Korsakova, WITH Ms. Papelbon voting “yea” and
134 Dr. Renn and Mr. Wedderburn voting “nay”, the Board approved the Tree Amigos Quote #201487, in the
135 amount of \$3,562.50, for the Beach Community Development District.

136 G. Exhibit 12: Consideration of Southeast Fitness Repair Proposal
137 Discussion ensued.

138 On a MOTION by Mr. Wedderburn, SECONDED by Ms. Papelbon, WITH ALL IN FAVOR, the Board
139 approved the Southeast Fitness Repair proposal, in the amount of \$775.60, for the Beach Community
140 Development District.

141 **EIGHTH ORDER OF BUSINESS – Staff Reports**

142 A. District Counsel
143 Mr. Haber had nothing further to report.

- 144 B. District Manager
 - 145 1. Resident(s) Subject Disciplinary Action
146 There being none, the next item followed.
 - 147 2. Complaint & Incident Management Tracker
148 Emailed to the Board prior to the meeting.
 - 149 3. Exhibit 13: Action Item Report
150
 - 151 4. Exhibit 14: Meeting Matrix

152 Supervisor Korsakova asked about the rules pertaining to what should be done when
153 there is a violation. Discussion ensued.

154 **NINTH ORDER OF BUSINESS – Vendor Reports**

155 A. Vesta Property Services

156 1. Exhibit 16: Lifestyle Amenity Management Report

157 Ms. Harden requested that the Board provide staff with directions to conduct additional
158 testing of the pool. Discussion ensued.

159 Mr. Ingram provided his report for the month to the Board. Discussion ensued.

160 Supervisor Renn asked for clarification on the process for directing staff. Discussion
161 ensued.

162 2. Exhibit 17: Field Management Report

163 Mr. Zastrocky provided his report and the landscape report for the month to the Board.
164 Discussion ensued.

165 The Board agreed to amend the agenda.

166 On a MOTION by Ms. Korsakova, SECONDED by Ms. Papelbon, WITH Mr. Calderaro and Dr. Renn
167 voting “yea” and Mr. Wedderburn voting “nay”, the Board amended the agenda to add ‘Consideration of
168 Tree Amigos Stake Removal Proposal’, for the Beach Community Development District.

169 Consideration of Tree Amigos Stake Removal Proposal

170 Discussion ensued. This item was tabled until further notice.

171 B. Tree Amigos

172 **TENTH ORDER OF BUSINESS – Discussions**

173 A. Exhibit 18: Letter to Commercial Property Owners Along Tamaya Blvd.

174 Mr. McInnes provided an update to the Board. Discussion ensued.

175 B. Number of Proposals Needed to Repair & Purchase Requests

176 Discussion ensued. The Board decided that 1 proposal was needed for anything between \$0-
177 \$5,000.00, 2 proposals were needed for anything between \$5,001.00-\$10,000.00, and 3 proposals
178 were needed for anything over \$10,001.00.

179 C. Pool Lighting & Lighting on Tamaya Blvd.

180 Mr. Zastrocky provided information regarding this discussion item. Discussion ensued.

181 D. Update on Controllers Based on Meeting with Tree Amigos

182 Supervisors Korsakova provided information regarding this from her recent meeting with Tree
183 Amigos. Discussion ensued.

184 The Board agreed to the amend the agenda to include the Consideration of Buehler Air
185 Conditioning Purchase proposal.

186 On a MOTION by Mr. Calderaro, SECONDED by Mr. Wedderburn, WITH ALL IN FAVOR, the Board
187 amended the agenda to include the Consideration of Buehler air Conditioning Purchase proposal, for the
188 Beach Community Development District.

189 Consideration of Buehler Air Conditioning Purchase Proposal

190 Mr. McInnes and Mr. Zastrocky explained the situation. Discussion ensued.

191 On a MOTION by Dr. Renn, SECONDED by Mr. Wedderburn, WITH ALL IN FAVOR, the Board
192 approved the Buehler Air Conditioning Purchase Proposal, for the Beach Community Development
193 District.

194 Supervisor Korsakova noted a commercial grade blowup slide was being offered to be purchased
195 for the district's use. Discussion ensued.

196 **ELEVENTH ORDER OF BUSINESS – Supervisors Requests**

197 Ms. Papelbon asked about having street signs on dead end streets be installed.

198 Mr. Wedderburn asked about summer camp quotes and CPR classes for residents.

199 Ms. Korsakova asked that the District Manager send the email that she received from the District
200 Counsel to the rest of the Board regarding trees in the ROW.

201 **TWELFTH ORDER OF BUSINESS – Audience Comments – New Business/Non-Agenda (limited to**
202 *3 minutes per individual)*

203 Mr. Thimann commented on the state of the District and whose responsibility it was to take care of it.
204 Discussion ensued.

205
206 Ms. Young commented on the money that was approved to be spent on items that were approved during
207 the meeting as well as the money being spent on having District Counsel present on the phone for the
208 whole meeting. Discussion ensued.

209 **THIRTEENTH ORDER OF BUSINESS – Action Items Summary**

210 The action items summary is available upon request.

211 **FOURTEENTH ORDER OF BUSINESS – Next Meeting Quorum Check: November 20, 6:00 PM**

212 All Board members present indicated that they would attend the November 20, 2023, Board
213 meeting.

214 **FIFTEENTH ORDER OF BUSINESS – Adjournment**

215 Mr. McInnes asked for final questions, comments, or corrections before requesting a motion to
216 adjourn the meeting. There being none, Dr. Renn made a motion to adjourn the meeting.

217 On a MOTION by Dr. Renn, SECONDED by Ms. Korsakova, WITH ALL IN FAVOR, the Board
218 adjourned the meeting at 9:49 p.m. for the Beach Community Development District.

219 **Each person who decides to appeal any decision made by the Board with respect to any matter considered*
220 *at the meeting is advised that person may need to ensure that a verbatim record of the proceedings is made,*
221 *including the testimony and evidence upon which such appeal is to be based.*

222 **Meeting minutes were approved at a meeting by vote of the Board of Supervisors at a publicly noticed**
223 **meeting held on November 20, 2023.**

224
225
226
227

228

229

Signature

Signature

Printed Name

Printed Name

230 **Title:** **Secretary** **Assistant Secretary**

Title: **Chairman** **Vice Chairman**

EXHIBIT 5

Beach
Community Development District

Financial Statements
(Unaudited)

Preliminary

September 30, 2023

Beach CDD
Balance Sheet
September 30, 2023

	<u>General Fund</u>	<u>Debt Service 2013A</u>	<u>Debt Service 2015A</u>	<u>Construction</u>	<u>Total</u>
1 ASSETS					
2 OPERATING ACCOUNT BU	\$ 351,134	\$ -	\$ -	\$ -	\$ 351,134
3 PAYPAL ACCOUNT BU	-	-	-	-	-
4 CHECKING ACCOUNT CS	48,525	-	-	-	48,525
5 DEBT CARD ACCOUNT CS	893	-	-	-	893
6 DEBT SERVICE ACCOUNTS:					
7 SINKING FUND	-	-	-	-	-
8 INTEREST FUND	-	-	-	-	-
9 REDEMPTION FUND	-	37	150	-	187
10 PREPAYMENT FUND	-	65,942	80,112	-	146,054
11 REVENUE FUND	-	441,641	127,737	-	569,378
12 OP REDEMPTION FUND	-	-	-	-	-
13 ACQ & CONS 2013A	-	-	-	-	-
14 ACQ & CONS 2015A	-	-	-	-	-
15 ACCOUNTS RECEIVABLE	700	-	-	-	700
16 ASSESSMENTS RECEIVABLE ON-ROLL	-	-	92,938	-	92,938
17 ASSESSMENTS RECEIVABLE OFF-ROLL	-	-	-	-	-
18 DUE FROM OTHER FUNDS	-	4,376	2,011	-	6,387
19 PREPAID	3,966	-	-	-	3,966
20 TOTAL ASSETS	\$ 405,217	\$ 511,997	\$ 302,948	\$ -	\$ 1,220,162
21 LIABILITIES					
22 ACCOUNTS PAYABLE	\$ 56,180	\$ -	\$ -	\$ -	\$ 56,180
23 DEFERRED REVENUE ON-ROLL	-	-	-	-	-
24 DEFERRED REVENUE OFF-ROLL	-	-	92,938	-	92,938
25 DUE TO OTHER FUNDS	-	-	-	-	-
26 OUTSTANDING CHECKS	-	-	-	-	-
27 TOTAL LIABILITIES	56,180	-	92,938	-	149,118
28 FUND BALANCE					
29 NONSPENDABLE					
30 PREPAID & DEPOSITS	3,966	-	-	-	3,966
31 CAPITAL RESERVES	109,319	-	-	-	109,319
32 OPERATING CAPITAL	-	-	-	-	-
33 UNASSIGNED	235,752	511,997	210,010	-	957,759
34 TOTAL FUND BALANCE	349,037	511,997	210,010	-	1,071,044
35 TOTAL LIABILITIES & FUND BALANCE	\$ 405,217	\$ 511,997	\$ 302,948	\$ -	\$ 1,220,162

Beach CDD
General Fund
Statement of Revenue, Expenditures, and Changes in Fund Balance
For the period from October 1, 2022 to September 30, 2023

	FY 2023 Adopted Budget	FY 2023 Month of September	FY 2023 Total Actual Year-to-Date	VARIANCE Over (Under) to Budget	% Actual YTD / FY Budget
1 REVENUE					
2 ASSESSMENTS ON-ROLL	\$ 1,402,321	\$ -	\$ 1,408,715	\$ 6,395	100%
3 ASSESSMENTS OFF-ROLL	216,924	-	216,924	0	100%
4 INTEREST REVENUE	-	3	29	29	
5 OTHER FINANCING SOURCES	5,000	9,811	55,013	50,013	1100%
6 CARRYFORWARD	-	-	-	-	
7 TOTAL REVENUE	\$ 1,624,245	\$ 9,814	\$ 1,680,681	\$ 56,436	103%
8 EXPENDITURES					
9 GENERAL & ADMINISTRATIVE EXPENSES					
10 TRUSTEE FEES	\$ 8,000	\$ -	\$ 8,200	\$ 200	103%
11 SUPERVISOR FEES-REGULAR MEETINGS	10,000	800	8,400	(1,600)	84%
12 SUPERVISOR FEES-WORKSHOPS	2,000	-	2,400	400	120%
13 DISTRICT MANAGEMENT	42,000	3,500	42,000	-	100%
14 ENGINEERING	2,500	-	2,157	(343)	86%
15 DISSEMINATION AGENT	2,500	-	2,500	-	100%
16 DISTRICT COUNSEL	7,500	-	22,266	14,766	297%
17 ASSESSMENT ADMINISTRATION	5,500	458	5,500	(0)	100%
18 REAMORTIZATION SCHEDULE	-	-	-	-	
19 ARBITRAGE REBATE CALCULATION	-	-	5,850	5,850	
20 AUDIT	6,000	-	3,250	(2,750)	54%
21 WEBSITE	1,515	175	2,513	998	166%
22 LEGAL ADVERTISING	1,750	296	5,138	3,388	294%
23 DUES, LICENSES & FEES	175	-	175	-	100%
24 GENERAL LIABILITY INSURANCE	4,057	-	-	(4,057)	0%
25 PUBLIC OFFICIAL INSURANCE	2,895	-	-	(2,895)	0%
26 OFFICE MISCELLANEOUS	2,000	32	8,383	6,383	419%
27 TOTAL GENERAL & ADMINISTRATIVE EXPENSES	98,392	5,261	118,731	20,339	121%
28 FIELD EXPENSES					
29 FIELD MANAGEMENT	133,553	12,517	119,225	(14,328)	89%
30 PROPERTY INSURANCE	89,054	-	88,097	(957)	99%
31 LAKE MAINTENANCE	21,600	1,767	20,460	(1,140)	95%
32 LANDSCAPING (INCLUDING MATERIALS)	402,792	500	291,892	(110,900)	72%
33 IRRIGATION (REPAIRS)	10,000	7,850	12,783	2,783	128%
34 ELECTRIC - STREET LIGHTS/IRRIGATION-JEA	188,475	17,698	246,910	58,435	131%
35 RIGHT OF WAY / LAKE MOWING	2,500	-	-	(2,500)	0%
36 ENTRY WATER FEATURE	7,500	-	-	(7,500)	0%
37 CARRYFORWARD REPLENISH	-	-	-	-	
38 CONTINGENCY - HURRICANE / STORM CLEAN UP	8,000	-	-	(8,000)	0%
39 COMMUNITY MAINTENANCE	8,000	13,822	34,070	26,070	426%
40 CAPITAL IMPROVEMENTS	39,080	-	3,575	(35,505)	9%
41 TOTAL FIELD EXPENSES	910,554	54,153	817,012	(93,542)	90%

42	AMENITY EXPENSES					
43	AMENITY MANAGEMENT	154,556	17,283	126,463	(28,093)	82%
44	BREEZEWAY STAFF	-	-	3,367	3,367	
45	LIFEGUARD	-	1,728	32,314	32,314	
46	SWIMMING POOL CHEMICALS	-	-	20,022	20,022	
47	SWIMMING POOL INSPECTION	-	-	851	851	
48	AMENITY GENERAL MAINTENANCE & REPAIRS	21,510	952	17,289	(4,221)	80%
49	AMENITY CLEANING	-	174	16,895	16,895	
50	AMENITY ELECTRIC/WATER AND SEWER	60,000	4,965	50,938	(9,062)	85%
51	AMENITY GATES/CONTROL ACCESS	5,000	188	13,606	8,606	272%
52	AMENITY WEBSITE/COMPUTER EQUIPMENT	1,590	-	2,233	643	140%
53	AMENITY INTERNET/CABLE	10,000	1,146	13,574	3,574	136%
54	AMENITY DUES & LICENSES	850	-	459	(391)	54%
55	AMENITY SECURITY	800	2,100	15,238	14,438	1905%
56	FITNESS EQUIPMENT MAINTENANCE	10,000	640	2,742	(7,258)	27%
57	LIFESTYLES PROGRAMMING	25,000	750	29,919	4,919	120%
58	AMENITY GAS	600	48	657	57	109%
59	TENNIS COURT MAINTENANCE - 4 CLAY COURTS	14,500	160	13,347	(1,153)	92%
60	LANDSCAPING MAINTENANCE AMENITY CENTER	68,400	-	25,333	(43,067)	37%
61	LANDSCAPE IMPROVEMENT	2,500	-	-	(2,500)	0%
62	AMENITY IRRIGATION (REPAIRS)	1,500	-	-	(1,500)	0%
63	PEST CONTROL	1,200	115	1,351	151	113%
64	AMENITY FIRE SYSTEM MONITORING	1,500	309	1,790	290	119%
65	ALARM	500	-	-	(500)	0%
66	TRASH COLLECTION	2,292	195	2,241	(51)	98%
67	TOTAL AMENITY EXPENSES	382,298	30,755	390,629	8,331	102%
68	ACCESS CONTROL /GATE HOUSE					
69	GUARD SERVICE	222,400	18,900	234,570	12,170	105%
70	GUARD HOUSE SUPPLIES	800	-	551	(249)	69%
71	GUARD HOUSE UTILITIES	3,800	199	2,977	(823)	78%
72	GUARD HOUSE REPAIR & MAINTENANCE	1,000	-	2,233	1,233	223%
73	BAR CODE EXPENSE	5,000	384	3,231	(1,769)	65%
74	TOTAL ACCESS CONTROL/GATE HOUSE EXPENSES	233,000	19,483	243,562	10,562	105%
75	TOTAL EXPENDITURES	1,624,245	109,653	1,569,936	(54,309)	97%
76	EXCESS OF REVENUE OVER (UNDER) EXPENDITURES	-	(99,839)	110,745	110,745	
77	OTHER FINANCING SOURCES & USES					
78	TRANSFER IN	-	-	-	-	
79	TRANSFER OUT	-	-	-	-	
80	TOTAL OTHER FINANCING SOURCES & USES	-	-	-	-	
81	FUND BALANCE - BEGINNING	239,612		238,292	(1,320)	
82	NET CHANGE IN FUND BALANCE	-	(99,839)	110,745	110,745	
83	FUND BALANCE - ENDING	\$ 239,612		\$ 349,037	\$ 109,425	
84	ANALYSIS OF FUND BALANCE					
85	NONSPENDABLE					
86	PREPAID & DEPOSITS	3,966		3,966		
87	CAPITAL RESERVES	109,319		109,319		
88	OPERATING CAPITAL	-		-		
89	UNASSIGNED	126,327		235,752		
90	TOTAL FUND BALANCE	\$ 239,612		\$ 349,037		

Beach CDD
Debt Service 2013A
Statement of Revenue, Expenditures, and Changes in Fund Balance
For the period from October 1, 2022 to September 30, 2023

	FY 2023 Adopted Budget	FY 2023 Actual Year-to-Date	VARIANCE Over (Under) to Budget
1 REVENUE			
2 ASSESSMENTS ON-ROLL	\$ 800,640	\$ 801,848	\$ 1,208
3 INTEREST REVENUE	-	8,761	8,761
4 MISC. REVENUE	-	80,614	80,614
5 TOTAL REVENUE	800,640	891,223	90,583
6 EXPENDITURES			
7 INTEREST EXPENSE			
8 November 1, 2022	-	313,908	313,908
9 May 1, 2023	313,920	311,425	(2,495)
10 November 1, 2023	308,058	-	(308,058)
11 PRINCIPAL RETIREMENT			
12 May 1, 2023	175,000	175,000	-
PRINCIPAL PREPAYMENT	-	85,000	85,000
13 TOTAL EXPENDITURES	796,978	885,333	(88,355)
14 EXCESS OF REVENUE OVER (UNDER) EXPENDITURES	3,663	5,891	2,228
15 OTHER FINANCING SOURCES (USES)			
16 TRANSFER IN	-	37	37
17 TRANSFER OUT (USES)	-	-	-
18 TOTAL OTHER FINANCING SOURCES (USES)	-	37	37
19 FUND BALANCE - BEGINNING	496,223	506,069	9,846
20 NET CHANGE IN FUND BALANCE	3,663	5,928	2,265
21 FUND BALANCE - ENDING	\$ 499,886	\$ 511,997	\$ 12,111

Beach CDD
Debt Service 2015A
Statement of Revenue, Expenditures, and Changes in Fund Balance
For the period from October 1, 2022 to September 30, 2023

	FY 2023 Adopted Budget	FY 2023 Actual Year-to-Date	VARIANCE Over (Under) to Budget
1 REVENUE			
2 ASSESSMENTS ON-ROLL	\$ 366,911	\$ 368,556	\$ 1,646
3 ASSESSMENTS OFF-ROLL	232,345	139,257	(93,087)
4 INTEREST REVENUE	-	1,177	1,177
5 MISC. REVENUE	-	76,873	76,873
6 TOTAL REVENUE	599,255	585,863	(13,392)
7 EXPENDITURES			
8 INTEREST EXPENSE			
9 November 1, 2022	-	221,988	221,988
10 May 1, 2023	221,988	221,988	-
11 November 1, 2023	217,268	-	(217,268)
12 PRINCIPAL RETIREMENT			
13 May 1, 2023	160,000	165,000	5,000
14 TOTAL EXPENDITURES	599,255	608,975	(9,720)
15 EXCESS OF REVENUE OVER (UNDER) EXPENDITURES	-	(23,112)	(23,112)
16 OTHER FINANCING SOURCES (USES)			
17 TRANSFER IN	-	149	149
18 TRANSFER OUT (USES)	-	-	-
19 TOTAL OTHER FINANCING SOURCES (USES)	-	149	149
20 FUND BALANCE - BEGINNING	96,818	232,972	136,154
21 NET CHANGE IN FUND BALANCE	-	(22,962)	(22,962)
22 FUND BALANCE - ENDING	\$ 96,818	\$ 210,010	\$ 113,192

Beach CDD Check Register - FY2023

Date	Ref. Num	Name	Memo	Deposits	Disbursements	Balance
09/30/2022		EOY Balance				295,536.89
10/01/2022	1114	Egis Insurance and Risk Advisors	FY Insurance Policy # 100122192 10/01/22-10/01/23		88,097.00	207,439.89
10/11/2022	1118	Kristin A. Robinson, MD	Refund of Deposit for rental of Pool Cabana		50.00	207,389.89
10/11/2022	100036	Advanced Security Specialist & Consulting	Invoice: T0092022A (Reference: Guard House Gate Access Management.)		8,370.00	199,019.89
10/11/2022	100037	Air Solutions Heating & Cooling Inc	Invoice: 0000094932 (Reference: Installed a new condenser fan motor, fan blade, and capacitor.)		2,038.39	196,981.50
10/11/2022	100038	Integrated Access Solutions	Invoice: 0001453 (Reference: Installation of Indoor Access Point.) Invoice: 0001472 (Referenc..		459.89	196,521.61
10/11/2022	100039	Life Fitness	Invoice: 7173030 (Reference: Clutch Kit.)		62.45	196,459.16
10/11/2022	100040	Southeast Fitness	Invoice: 100493 (Reference: Semi-annually scheduled preventative maintenance.)		640.00	195,819.16
10/11/2022	100041	Southeastern Paper Group	Invoice: 05717495 (Reference: Supplies.)		423.90	195,395.26
10/11/2022	100042	Staples	Invoice: 8067623768 (Reference: Office Supplies.)		48.07	195,347.19
10/11/2022	100043	Sun State Nursery & Landscaping, Inc	Invoice: 7821 (Reference: Irrigation Repairs.) Invoice: 7911 (Reference: Istallation of Clock...		2,236.49	193,110.70
10/11/2022	100044	Wayne Automatic Fire Sprinklers Inc.	Invoice: 952684 (Reference: Annual Extinguisher Certification Inspection.)		352.61	192,758.09
10/14/2022	100045	10-S Tennis Supply & Dinkshot Pickleball	Invoice: 156365 (Reference: Aluminum Drag Broom.) Invoice: 156337 (Reference: 10-S Linesr		437.61	192,320.48
10/14/2022	100046	Advanced Security Specialist & Consulting	Invoice: T0092022B (Reference: Guard House Gate Access Management.) Invoice: TA0092022		12,570.00	179,750.48
10/14/2022	100047	Innersync	Invoice: 20817 (Reference: Website Services.)		1,515.00	178,235.48
10/14/2022	100048	Sun State Nursery & Landscaping, Inc	Invoice: 7986 (Reference: October Landscape Maintenance.)		35,213.10	143,022.38
10/14/2022	100050	The Lake Doctors, Inc.	Invoice: 36532B (Reference: Water Management Zone 1 & 2.)		1,395.00	141,627.38
10/14/2022	100051	Turner Pest Control	Invoice: 19160304 (Reference: Monthly pest control.)		104.74	141,522.64
10/14/2022	100052	Vesta Property Services	Invoice: 403326 (Reference: September Fees.)		19,605.00	121,917.64
10/14/2022	100053	VGlobal Tech	Invoice: 4366 (Reference: Email hosting.)		50.00	121,867.64
10/14/2022	101422ACH1	JEA	Service for the month of September		27,918.90	93,948.74
10/15/2022	101522ACH1	Comcast	12788 Meritace Blvd MINI MDTA 9/28/22 to 10/27/22		535.58	93,413.16
10/17/2022	1119	Dominik Guess	Refund for Rental Cancellation		200.00	93,213.16
10/17/2022	1120	Instant PhotoCube	80's Casino Night		475.00	92,738.16
10/17/2022	101722ACH1	Comcast	12750 Meritage Blvd. GATEHOUSE 9/30-10/29/22		212.20	92,525.96
10/18/2022	101822ACH1	TECO	12545 Beach Blvd - 8/19/22 - 9/20/22		37.07	92,488.89
10/20/2022			Deposit	1,749.54		94,238.43
10/21/2022	102122ACH1	Florida Natural Gas	Fuel and Inside FGT Z3 8/19/22 - 9/18/22		17.79	94,220.64
10/22/2022	102222ACH1	Comcast	12788 Meritage Blvd. OFC 4 10/3-11/2/22		351.09	93,869.55
10/23/2022	ACH 102322	Credit Card transactions			693.49	93,176.06
10/24/2022	100054	Advanced Security Specialist & Consulting	Invoice: T0102022A (Reference: Guard House Gate Access Management.)		8,100.00	85,076.06
10/24/2022	100055	Integrated Access Solutions	Invoice: 0001945 (Reference: Service call.) Invoice: 0001950 (Reference: Service Call.) In...		900.00	84,176.06
10/24/2022	100056	Life Fitness	Invoice: 7195361 (Reference: Seat Pad.)		117.75	84,058.31
10/24/2022	100057	Southeastern Paper Group	Invoice: 05660098 (Reference: Paper Supplies.)		355.77	83,702.54
10/24/2022	100058	Staples	Invoice: 8067869974 (Reference: Office Supplies.)		400.17	83,302.37
10/26/2022	100059	Integrated Access Solutions	Invoice: 0001465 (Reference: Labor for installation, setup and testing.)		360.00	82,942.37
10/27/2022	102722ACH1	Comcast	13077 Beach Blvd. PEDESTRIAN GATE 10/10 -11/9/22		194.35	82,748.02
10/31/2022			Service Charge		1.45	82,746.57
10/31/2022		EOM Balance		1,749.54	214,539.86	82,746.57
11/03/2022			Deposit	3,000.00		85,746.57
11/07/2022	100060	DPFG M&C	Invoice: 403568 (Reference: Dissemination Agent.) Invoice: 403505 (Reference: District Manag		6,458.33	79,288.24
11/07/2022	100061	Advanced Security Specialist & Consulting	Invoice: TA0102022 (Reference: Amenities security.) Invoice: T0102022B (Reference: Guard H		11,070.00	68,218.24
11/07/2022	100062	Big Z Pool Service, LLC	Invoice: 11382 (Reference: Comp Pool, VFD Drive.)		1,970.00	66,248.24
11/07/2022	100063	Custom Pump & Controls, Inc.	Invoice: 22-314-04 (Reference: QUARTERLY LIFT STATION INSPECTION.)		150.00	66,098.24
11/07/2022	100064	GFL Environmental	Invoice: UG0000080959 (Reference: Nov 01/22 - Nov 30/22.)		162.01	65,936.23
11/07/2022	100065	Integrated Access Solutions	Invoice: 0002027 (Reference: BAI Barcodes Black on Black.) Invoice: 0002035 (Reference: ped		1,740.01	64,196.22
11/07/2022	100066	Kutak Rock LLP	Invoice: 3126899 (Reference: General Counsel.)		1,320.00	62,876.22

11/07/2022	100067	Sun State Nursery & Landscaping, Inc	Invoice: 8275 (Reference: Irrigation Repairs.) Invoice: 8273 (Reference: Irrigation Repairs. ...		779.17	62,097.05
11/07/2022	100068	TEKWave Solutions LLC	Invoice: 102622- (Reference: VMS - November 2022.)		295.00	61,802.05
11/07/2022	100069	Turner Pest Control	Invoice: 19363970 (Reference: Commercial Pest Control.)		104.74	61,697.31
11/07/2022	100070	VGlobal Tech	Invoice: 4416 (Reference: Email hosting.)		50.00	61,647.31
11/07/2022	100071	Wayne Automatic Fire Sprinklers Inc.	Invoice: 998491 (Reference: Annual Sprinkler Inspection.)		309.38	61,337.93
11/14/2022	1121	Matthew Calderaro	BOS MTG 11/7/22		200.00	61,137.93
11/14/2022	1122	Robert Renn	BOS MTG 11/7/22		200.00	60,937.93
11/14/2022	1123	Shelia Papelbon	BOS MTG 11/7/22		200.00	60,737.93
11/14/2022	1124	Stefanos Kounoupas	BOS MTG 11/7/22		200.00	60,537.93
11/16/2022	111622ACH1	JEA	Service for the month of October		23,682.22	36,855.71
11/17/2022			Deposit	187,055.02		223,910.73
11/17/2022	111722ACH1	TECO	12545 Beach Blvd - 09/21/2022 to 10/20/2022		37.08	223,873.65
11/18/2022	111822ACH1	Comcast	12788 Meritace Blvd MINI MDTA 10/28/22 to 11/27/22		534.81	223,338.84
11/21/2022	ACH11/21/22	Florida Natural Gas	Fuel and Inside FGT Z3 9/20/22 -10/20/22		15.19	223,323.65
11/21/2022	1125	FLORIDA DEPT OF ECONOMIC OPPORTUNIT	FY 2022/2023 Special District Fee Invoice/Update Form		175.00	223,148.65
11/21/2022	100072	Integrated Access Solutions	Invoice: 0002123 (Reference: Emergency Service Call.)		180.00	222,968.65
11/21/2022	100073	Game Time Game Truck, LLC	Invoice: 3014 (Reference: 2 Hour Game Truck.)		504.00	222,464.65
11/21/2022	100074	DPFG M&C	Invoice: 404412 (Reference: District Management Services.)		3,958.33	218,506.32
11/21/2022	100075	Sun State Nursery & Landscaping, Inc	Invoice: 8366 (Reference: November Landscape Maintenance.) Invoice: 8274 (Reference: Irrigat		35,533.06	182,973.26
11/21/2022	100076	The Lake Doctors, Inc.	Invoice: 45252B (Reference: Water Management Zone 1 & 2.)		1,395.00	181,578.26
11/21/2022	112122ACH1	Comcast	12750 Meritage Blvd. GATEHOUSE10/30/22 to 11/29/22		211.88	181,366.38
11/22/2022			Deposit	54,231.04		235,597.42
11/23/2022			Deposit	192.36		235,789.78
11/23/2022	ACH 112322	Credit Card transactions			1,245.71	234,544.07
11/25/2022			Deposit	284,806.31		519,350.38
11/25/2022	112522ACH1	Comcast	12788 Meritage Blvd. OFC 4 11/3/22 - 12/2/22		351.09	518,999.29
11/30/2022	113022ACH1	Comcast	13077 Beach Blvd. PEDESTRIAN GATE 11/10/22 to 12/9/22		194.35	518,804.94
11/30/2022			Service Charge		1.70	518,803.24
11/30/2022	EOM Balance			529,284.73	93,228.06	518,803.24
12/02/2022	100077	Vesta Property Services	Invoice: 404248 (Reference: October Fees.)		20,846.14	497,957.10
12/05/2022			Deposit	1,346,682.83		1,844,639.93
12/06/2022			Deposit	1,950.00		1,846,589.93
12/06/2022			Deposit	215,761.07		2,062,351.00
12/12/2022	100078	10-S Tennis Supply & Dinkshot Pickleball	Invoice: 157124 (Reference: Pro-Screen Open Mesh.)		882.34	2,061,468.66
12/12/2022	100079	Advanced Security Specialist & Consulting	Invoice: T0112022A (Reference: Guard House Gate Access Management.)		9,300.00	2,052,168.66
12/12/2022	100080	Bob's Backflow & Plumbiong Services	Invoice: 87517 (Reference: Backflow Test.)		450.00	2,051,718.66
12/12/2022	100081	Integrated Access Solutions	Invoice: 0002199 (Reference: Wireless HDMI adapter.)		369.00	2,051,349.66
12/12/2022	100083	Kutak Rock LLP	Invoice: 113022-23-1 (Reference: General Counsel.)		4,558.50	2,046,791.16
12/12/2022	100084	Southeast Fitness	Invoice: 100363 (Reference: 9/6/2022 Diagnosis or Repair.)		150.00	2,046,641.16
12/12/2022	100085	Southeastern Paper Group	Invoice: 05773688 (Reference: ECO-AIR.)		53.32	2,046,587.84
12/12/2022	100086	Sun State Nursery & Landscaping, Inc	Invoice: 8551 (Reference: Fix Breaks on the back side of wall.) Invoice: 8550 (Reference: Irr...		36,036.41	2,010,551.43
12/12/2022	100087	TEKWave Solutions LLC	Invoice: 5414 (Reference: December 2022.)		295.00	2,010,256.43
12/12/2022	100088	The Lake Doctors, Inc.	Invoice: 670593 (Reference: Monthly Water Management Service.) Invoice: 57370b (Reference:		3,095.00	2,007,161.43
12/12/2022	100089	Turner Pest Control	Invoice: 19972952 (Reference: Pest Control.)		104.74	2,007,056.69
12/12/2022	100090	Vesta Property Services	Invoice: 405450 (Reference: November Fees.)		19,793.78	1,987,262.91
12/12/2022	100091	VGlobal Tech	Invoice: 4492 (Reference: Email hosting.)		50.00	1,987,212.91
12/12/2022	100092	The Perfect Pour	Invoice: 0000151A (Reference: Bar Service for Halloween Party 10/21/22.)		625.00	1,986,587.91
12/12/2022	100093	Daytona Beach News-Journal	Invoice: 0005017635 (Reference: Oct 1 - Oct 31, 2022.)		1,003.25	1,985,584.66
12/13/2022	1126	Matthew Calderaro	BOS MTG 12/5/22		200.00	1,985,384.66
12/13/2022	1127	Robert Renn	BOS MTG 12/5/22		200.00	1,985,184.66
12/13/2022	1128	Shelia Papelbon	BOS MTG 12/5/22		200.00	1,984,984.66
12/14/2022			Deposit	192.36		1,985,177.02

12/14/2022	121422ACH1	JEA	Service for the month of November		25,621.04	1,959,555.98
12/16/2022			Deposit	165,311.36		2,124,867.34
12/19/2022	121922ACH1	Comcast	12788 Meritace Blvd MINI MDTA 11/28/22 - 12/27/22		534.81	2,124,332.53
12/20/2022	122022ACH1	Comcast	12750 Meritage Blvd. GATEHOUSE11/30/22 to 12/29/22		211.88	2,124,120.65
12/20/2022	122022ACH2	TECO	12545 Beach Blvd - 10/20/2022 -11/28/22		37.70	2,124,082.95
12/22/2022	122222ACH1	Florida Natural Gas	Fuel and Inside FGT Z3 10/20/22 to 11/28/22		14.35	2,124,068.60
12/23/2022	100094	DPFG M&C	Invoice: 405570 (Reference: District Management Services.)		3,958.33	2,120,110.27
12/23/2022	100095	Advanced Security Specialist & Consulting	Invoice: TA0112022 (Reference: Amenities security.) Invoice: T0112022B (Reference: Guard H		11,460.00	2,108,650.27
12/23/2022	100096	Integrated Access Solutions	Invoice: 0002285 (Reference: Gate Repair.) Invoice: 0002291 (Reference: Guard House Gate Ac		3,192.16	2,105,458.11
12/23/2022	100097	Southeastern Paper Group	Invoice: 05765238 (Reference: Supplies.) Invoice: 05748187 (Reference: Supplies.)		824.54	2,104,633.57
12/23/2022	100098	Staples	Invoice: 8068566313 (Reference: Office Supplies.)		383.73	2,104,249.84
12/23/2022	100099	Vesta Property Services	Invoice: 403470 (Reference: Billable Expenses.)		3,170.38	2,101,079.46
12/23/2022	100100	Daytona Beach News-Journal	Invoice: 0005119397 (Reference: Advertising.)		1,324.92	2,099,754.54
12/23/2022	ACH 122322	Credit Card transactions			301.35	2,099,453.19
12/27/2022	1129	Matthew Calderaro	BOS MTG 12/19/22		200.00	2,099,253.19
12/27/2022	1130	Robert Renn	BOS MTG 12/19/22		200.00	2,099,053.19
12/27/2022	1131	Shelia Papelbon	BOS MTG 12/19/22		200.00	2,098,853.19
12/27/2022	1132	Stefanos Kounoupas	BOS MTG 12/19/22		200.00	2,098,653.19
12/27/2022	122722ACH1	Comcast	12788 Meritage Blvd. OFC 4 12/3/22 - 1/2/23		351.09	2,098,302.10
12/28/2022	1133	DPFG M&C	August Billable Expenses		30.63	2,098,271.47
12/30/2022			Deposit	308.38		2,098,579.85
12/30/2022	123022ACH1	Comcast	13077 Beach Blvd. PEDESTRIAN GATE 12/10/22 to 1/9/23		194.35	2,098,385.50
12/31/2022			Service Charge		1.75	2,098,383.75
12/31/2022	EOM Balance			1,730,206.00	150,625.49	2,098,383.75
01/03/2023	1135	Magnetix DJ Services	Reference: Emcee & DJ Polar Plunge. https://dpfg.payableslockbox.com/DocView/InvoiceViewer		400.00	2,097,983.75
01/03/2023	1136	Shannon Brooke Thomas	Reference: Halloween Paint and Sip Event. https://dpfg.payableslockbox.com/DocView/InvoiceVi		150.00	2,097,833.75
01/03/2023	1137	Art-Z-Faces, Inc.	Reference: Santa Appearance. https://dpfg.payableslockbox.com/DocView/InvoiceViewer.aspx?i=		300.00	2,097,533.75
01/03/2023	100101	Advanced Security Specialist & Consulting	Invoice: T0122022A (Reference: Guard House Gate Access Management.)		9,000.00	2,088,533.75
01/03/2023	100102	Southeastern Paper Group	Invoice: 05783796 (Reference: Supplies.)		258.71	2,088,275.04
01/03/2023	100103	Vesta Property Services	Invoice: 404351 (Reference: Billable Expenses.)		2,894.83	2,085,380.21
01/03/2023	100104	Daytona Beach News-Journal	Invoice: 0005097697 (Reference: Advertising.)		14.83	2,085,365.38
01/04/2023			Deposit	875.00		2,086,240.38
01/05/2023	1140	BNY Mellon Tax Distributions	Tax Distributions 2013A		689,260.69	1,396,979.69
01/05/2023	1141	BNY Mellon Tax Distributions	Tax Distributions 2015A		316,807.18	1,080,172.51
01/06/2023			Deposit	79,101.86		1,159,274.37
01/09/2023			Deposit	54,231.04		1,213,505.41
01/09/2023	100105	Advanced Security Specialist & Consulting	Invoice: TA0122022 (Reference: Amenities security.) Invoice: T0122022B (Reference: Guard H		12,060.00	1,201,445.41
01/09/2023	100106	Bob's Backflow & Plumbiong Services	Invoice: 88072 (Reference: Backflow Test.)		227.49	1,201,217.92
01/09/2023	100107	Integrated Access Solutions	Invoice: 0002350 (Reference: Service Call.) Invoice: 0001921 (Reference: Comcast modem bad		272.00	1,200,945.92
01/09/2023	100108	Kutak Rock LLP	Invoice: 3158252 (Reference: General Counsel.)		1,092.50	1,199,853.42
01/09/2023	100109	Sun State Nursery & Landscaping, Inc	Invoice: 8943 (Reference: January Landscape Maintenance.)		35,213.10	1,164,640.32
01/09/2023	100110	TEKWave Solutions LLC	Invoice: 5467 (Reference: Community Visitor Management Software.)		295.00	1,164,345.32
01/09/2023	100111	The Lake Doctors, Inc.	Invoice: 63731B (Reference: Water Management.)		1,767.00	1,162,578.32
01/09/2023	100112	Turner Pest Control	Invoice: 20497453 (Reference: Commercial Pest Control.)		104.74	1,162,473.58
01/09/2023	100113	VGlobal Tech	Invoice: 4623 (Reference: Email hosting.)		50.00	1,162,423.58
01/09/2023	100114	Wayne Automatic Fire Sprinklers Inc.	Invoice: 1014988 (Reference: WayneNet Fire Alarm Monitoring.)		750.00	1,161,673.58
01/09/2023	100115	Oxi Fresh Carpet Cleaning	Invoice: 1050 (Reference: Tile and Grout & Carpet Cleaning.) Invoice: 1051 (Reference: Tile a.		2,355.25	1,159,318.33
01/09/2023	100116	Bouncers, Slides, and More Inc.	Invoice: 12152022.03 (Reference: Movie Night.) Invoice: 10082022.16 (Reference: Obstacle Cc		1,330.00	1,157,988.33
01/15/2023	11523ACH1	Comcast	12788 Meritace Blvd MINI MDTA 12/28/22 - 1/27/23		547.90	1,157,440.43
01/17/2023	11723ACH1	Comcast	12750 Meritage Blvd. GATEHOUSE12/30/22 to 1/29/23		215.97	1,157,224.46
01/17/2023	100117	DPFG M&C	Invoice: 404329 (Reference: October Billable Expenses.)		48.95	1,157,175.51
01/18/2023	11823ACH1	TECO	12545 Beach Blvd - 11/28/22 - 12/19/22		40.25	1,157,135.26

01/18/2023			Deposit	192.36		1,157,327.62
01/19/2023	11922ACH1	JEA	Service for the month of December		27,981.75	1,129,345.87
01/20/2023	100118	DPFG M&C	Invoice: 406418 (Reference: December Billable Expenses.) Invoice: 406478 (Reference: District		4,104.61	1,125,241.26
01/20/2023	100119	Integrated Access Solutions	Invoice: 0002427 (Reference: Labor for installation, setup and testing.)		899.63	1,124,341.63
01/20/2023	100121	Sun State Nursery & Landscaping, Inc	Invoice: 8548 (Reference: Irrigation Repairs made during Inspection.)		142.18	1,124,199.45
01/20/2023	100122	Coastal Maintenance M.E. LLC	Invoice: 4165 (Reference: Holiday Lights.)		5,578.00	1,118,621.45
01/22/2023	12223ACH1	Comcast	12788 Meritage Blvd. OFC 4 1/3/23 - 2/2/23		361.28	1,118,260.17
01/23/2023	ACH012323	Florida Natural Gas	Fuel and Inside FGT Z3 11/28/22 to 12/19/22		23.99	1,118,236.18
01/23/2023	1142	Chance Wedderburn	BOS MTG 1/16/23		200.00	1,118,036.18
01/23/2023	1143	Matthew Calderaro	BOS MTG 1/16/23		200.00	1,117,836.18
01/23/2023	1144	Robert Renn	BOS MTG 1/16/23		200.00	1,117,636.18
01/23/2023	1145	Shelia Papelbon	BOS MTG 1/16/23		200.00	1,117,436.18
01/23/2023	1151	Stefanos Kounoupas	BOS MTG 1/16/23		200.00	1,117,236.18
01/23/2023	ACH 012323	Credit Card transactions			908.87	1,116,327.31
01/24/2023	1152	Brian T. Shirley	Stand-Up Comedy Show for Valentine's Day Cocktail Party		400.00	1,115,927.31
01/24/2023	1153	Ebony Lunsford	Cocktail Service		500.00	1,115,427.31
01/24/2023			Deposit	127,429.74		1,242,857.05
01/25/2023	100123	Advanced Security Specialist & Consulting	Invoice: T0012023A (Reference: Guard House Gate Access Management.)		9,300.00	1,233,557.05
01/25/2023	100124	Custom Pump & Controls, Inc.	Invoice: 23-314-01 (Reference: QUARTERLY LIFT STATION INSPECTION.)		150.00	1,233,407.05
01/25/2023	100125	E.T.M.	Invoice: 0206237 (Reference: Engineering Services.)		1,073.25	1,232,333.80
01/25/2023	100126	GFL Environmental	Invoice: UG0000087355 (Reference: Trash Service.)		193.73	1,232,140.07
01/25/2023	100127	Southeastern Paper Group	Invoice: 05806313 (Reference: PURELL HAND SANITIZING.)		175.71	1,231,964.36
01/25/2023	100128	Sun State Nursery & Landscaping, Inc	Invoice: 9019 (Reference: Irrigation Repairs Made During Monthly Inspection.)		151.79	1,231,812.57
01/25/2023	100129	Vesta Property Services	Invoice: 406387 (Reference: Billable Expenses.)		2,193.93	1,229,618.64
01/25/2023	100130	Daytona Beach News-Journal	Invoice: 0005202822 (Reference: Advertising.)		578.28	1,229,040.36
01/27/2023	1154	BNY Mellon Payment/Trustee Fees	Trustee Fees 2013A: November 01, 2022 to October 31, 2023		4,100.00	1,224,940.36
01/27/2023	1155	BNY Mellon Payment/Trustee Fees	Trustee Fees 2015A: November 01, 2022 to October 31, 2023		4,100.00	1,220,840.36
01/27/2023			Deposit	1,975.00		1,222,815.36
01/30/2023	1156	Magnetix DJ Services	Reference: Emcee & DJ Member Music Bingo Night		350.00	1,222,465.36
01/30/2023	13023ACH1	Comcast	13077 Beach Blvd. PEDESTRIAN GATE Jan 10, 2023 to Feb 09, 2023		199.35	1,222,266.01
01/31/2023			Service Charge		2.55	1,222,263.46
01/31/2023		EOM Balance		263,805.00	1,139,925.29	1,222,263.46
02/09/2023			Deposit	192.36		1,222,455.82
02/09/2023	100131	Advanced Security Specialist & Consulting	Invoice: T0012023B (Reference: Guard House Gate Access Management.)		9,600.00	1,212,855.82
02/09/2023	100132	Kutak Rock LLP	Invoice: 3170780 (Reference: General Counsel.)		1,897.50	1,210,958.32
02/09/2023	100133	Southeastern Paper Group	Invoice: 05817499 (Reference: Paper Supplies.)		297.63	1,210,660.69
02/09/2023	100134	Sun State Nursery & Landscaping, Inc	Invoice: 9158 (Reference: Valve Replacement.) Invoice: 9159 (Reference: Repair of break.) ...		36,225.90	1,174,434.79
02/09/2023	100135	TEKWave Solutions LLC	Invoice: 5523 (Reference: Visitor Management Software-JAN.)		295.00	1,174,139.79
02/09/2023	100136	The Lake Doctors, Inc.	Invoice: 72574B (Reference: Water Management.)		1,767.00	1,172,372.79
02/09/2023	100137	Turner Pest Control	Invoice: 20597624 (Reference: Pest Control.)		115.21	1,172,257.58
02/09/2023	100138	VGlobal Tech	Invoice: 4735 (Reference: Email:Email hosting.)		50.00	1,172,207.58
02/09/2023	100139	Community Advisors, LLC	Invoice: 1537 (Reference: Reserve Analysis.)		4,900.00	1,167,307.58
02/13/2023	100140	GFL Environmental	Invoice: UG000090424 (Reference: Trash Service.)		177.88	1,167,129.70
02/15/2023	21523ACH1	JEA	Service for the month of January		20,109.16	1,147,020.54
02/17/2023			Deposit	9,913.18		1,156,933.72
02/21/2023	22123ACH1	Comcast	12788 Meritace Blvd MINI MDTA 1/28/22 - 2/27/23		548.46	1,156,385.26
02/21/2023	22123ACH2	Comcast	12750 Meritage Blvd. GATEHOUSE1/30/23 to 2/28/23		216.20	1,156,169.06
02/21/2023	22123ACH3	TECO	12545 Beach Blvd - 12/20/22 - 1/23/23		56.44	1,156,112.62
02/23/2023	100141	Integrated Access Solutions	Invoice: 0002621 (Reference: Service Call.)		264.00	1,155,848.62
02/23/2023	100142	Southeastern Paper Group	Invoice: 05802879 (Reference: Paper Supplies.)		386.21	1,155,462.41
02/23/2023	100143	Vesta Property Services	Invoice: 406329 (Reference: December Fees.) Invoice: 405487 (Reference: Billable Expenses.)		46,194.31	1,109,268.10
02/23/2023	22323ACH1	Florida Natural Gas	Fuel and Inside FGT Z3 12/19/22 - 1/23/23		42.56	1,109,225.54

02/23/2023	ACH 022323	Credit Card transactions		1,977.35	1,107,248.19
02/27/2023	100144	DPFG M&C	Invoice: 407496 (Reference: January Billable Expenses.) Invoice: 407582 (Reference: District ...	4,066.06	1,103,182.13
02/27/2023	100145	Advanced Security Specialist & Consulting	Invoice: T0022023A (Reference: Guard House Gate Access Management.) Invoice: TA0012023	10,980.00	1,092,202.13
02/27/2023	100146	Bob's Backflow & Plumbing Services	Invoice: 89479 (Reference: Backflow Test.)	225.00	1,091,977.13
02/27/2023	100147	GFL Environmental	Invoice: UG0000093668 (Reference: Trash Service.)	177.88	1,091,799.25
02/27/2023	100148	Integrated Access Solutions	Invoice: 0002655 (Reference: BAI Barcodes Black on Black.)	383.78	1,091,415.47
02/27/2023	100149	Sun State Nursery & Landscaping, Inc	Invoice: 9472 (Reference: Irrigation Repairs made during Inspection.)	493.19	1,090,922.28
02/27/2023	100150	Turner Pest Control	Invoice: 20704326 (Reference: Pest Control.)	115.21	1,090,807.07
02/27/2023	100151	Vesta Property Services	Invoice: 407489 (Reference: Billable Expenses.)	592.85	1,090,214.22
02/27/2023	1157	Chance Wedderburn	BOS MTG 2/20/23	200.00	1,090,014.22
02/27/2023	1158	Matthew Calderaro	BOS MTG 2/20/23	200.00	1,089,814.22
02/27/2023	1159	Robert Renn	BOS MTG 2/20/23	200.00	1,089,614.22
02/27/2023	1160	Shelia Papelbon	BOS MTG 2/20/23	200.00	1,089,414.22
02/27/2023	1161	Stefanos Kounoupas	BOS MTG 2/20/23	200.00	1,089,214.22
02/27/2023		Deposit		1,375.00	1,090,589.22
02/27/2023		Deposit		3,297.16	1,093,886.38
02/28/2023		Service Charge		1.40	1,093,884.98
02/28/2023	EOM Balance			14,777.70	143,156.18
03/01/2023	ACH030123	Bank United	Check 126 deposited 02/27 Chargeback Fee	35.00	1,093,849.98
03/02/2023	030223ACH1	Comcast	13077 Beach Blvd. PEDESTRIAN GATE 2/10/23 - 3/9/23	199.35	1,093,650.63
03/03/2023	1162	Live Entertainment Solutions, LLC	DJ for Trivia Night on 3/16/23 including supplies	275.00	1,093,375.63
03/06/2023		Deposit		6,849.03	1,100,224.66
03/08/2023		Deposit		192.36	1,100,417.02
03/09/2023	100152	Advanced Security Specialist & Consulting	Invoice: TA0022023 (Reference: Amenities security.) Invoice: T0022023B (Reference: Guard H	9,960.00	1,090,457.02
03/09/2023	100153	Kutak Rock LLP	Invoice: 3182997 (Reference: General Counsel.)	1,901.50	1,088,555.52
03/09/2023	100154	TEKWave Solutions LLC	Invoice: 5578 (Reference: Visitor Management Software.)	295.00	1,088,260.52
03/09/2023	100155	First Coast Mulch	Invoice: 4831 (Reference: Mulch Installation:Playground Chips.)	3,575.00	1,084,685.52
03/13/2023	100156	Southeastern Paper Group	Invoice: 05829171 (Reference: Supplies.)	376.43	1,084,309.09
03/13/2023	100157	Sun State Nursery & Landscaping, Inc	Invoice: 9616 (Reference: March Landscape Maintenance.)	35,213.10	1,049,095.99
03/13/2023	100158	The Lake Doctors, Inc.	Invoice: 76968B (Reference: Water Management.)	1,767.00	1,047,328.99
03/13/2023	100159	Vesta Property Services	Invoice: 408152 (Reference: Amenity Management.)	18,973.93	1,028,355.06
03/13/2023	100160	VGlobal Tech	Invoice: 4781 (Reference: Email hosting.)	50.00	1,028,305.06
03/13/2023	100161	Wayne Automatic Fire Sprinklers Inc.	Invoice: 1030521 (Reference: Annual Extinguisher Certification Inspection.) Invoice: 1030371 .	346.73	1,027,958.33
03/14/2023	1163	Matthew Calderaro	BOS MTG 3/09/23	200.00	1,027,758.33
03/14/2023	1164	Stefanos Kounoupas	BOS MTG 3/9/23	200.00	1,027,558.33
03/16/2023		Deposit		61,862.73	1,089,421.06
03/17/2023	31723ACH1	JEA	Service for the month of February	18,352.18	1,071,068.88
03/20/2023	ACH032023	TECO	12545 Beach Blvd - 1/24/23 - 2/21/23	41.09	1,071,027.79
03/20/2023	032023ACH1	Comcast	12750 Meritage Blvd. GATEHOUSE 3/01/23 to 3/29/23	216.20	1,070,811.59
03/20/2023	32023ACH2	Comcast	12788 Meritace Blvd MINI MDTA 2/28/22 - 3/27/23	548.42	1,070,263.17
03/23/2023	ACH032323	Florida Natural Gas	Fuel and Inside FGT Z3 1/23/23 - 2/21/23	16.08	1,070,247.09
03/23/2023	100162	DPFG M&C	Invoice: 408425 (Reference: District Management Services.) Invoice: 408367 (Reference: Billab	4,224.33	1,066,022.76
03/23/2023	100163	Advanced Security Specialist & Consulting	Invoice: T0032023A (Reference: Guard House Gate Access Management.)	9,000.00	1,057,022.76
03/23/2023	100165	Vesta Property Services	Invoice: 408342 (Reference: Billable Expenses.)	603.48	1,056,419.28
03/23/2023	ACH 032323	Credit Card transactions		2,530.22	1,053,889.06
03/27/2023	22723ACH1	Comcast	12788 Meritage Blvd. OFC 4 2/3/23 - 3/2/23	361.29	1,053,527.77
03/27/2023	1165	Chance Wedderburn	BOS MTG 3/20/23	200.00	1,053,327.77
03/27/2023	1166	Matthew Calderaro	BOS MTG 3/20/23	200.00	1,053,127.77
03/27/2023	1167	Robert Renn	BOS MTG 3/20/23	200.00	1,052,927.77
03/27/2023	1168	Shelia Papelbon	BOS MTG 3/20/23	200.00	1,052,727.77
03/27/2023	100166	GFL Environmental	Invoice: UG0000096764 (Reference: Trash Service.)	195.31	1,052,532.46
03/27/2023	100167	Integrated Access Solutions	Invoice: 0002826 (Reference: Installation, set-up & testing.)	1,383.00	1,051,149.46

03/27/2023	032723ACH1	Comcast	12788 Meritage Blvd. OFC 4 3/3/23 - 4/2/23		361.24	1,050,788.22
03/28/2023			Deposit	600.00		1,051,388.22
03/30/2023	030323ACH1	Comcast	13077 Beach Blvd. PEDESTRIAN GATE Mar 10, 2023 to Apr 09, 2023		199.35	1,051,188.87
03/31/2023	100168	Bob's Backflow & Plumbiong Services	Invoice: 90342 (Reference: replace the existing backflow preventer.)		1,597.00	1,049,591.87
03/31/2023	100169	Southeastern Paper Group	Invoice: 05856941 (Reference: Paper Supplisr.) Invoice: 05853072 (Reference: Paper Supplies.		423.65	1,049,168.22
03/31/2023	100170	Sun State Nursery & Landscaping, Inc	Invoice: 9802 (Reference: Irrigation Repairs.)		925.95	1,048,242.27
03/31/2023	100171	TEKWave Solutions LLC	Invoice: 5632 (Reference: VMS - APRIL.)		295.00	1,047,947.27
03/31/2023	100172	Turner Pest Control	Invoice: 617040310 ()		115.21	1,047,832.06
03/31/2023	100173	Beaches Electrical Service, Inc.	Invoice: 11802 (Reference: Service Call.)		187.50	1,047,644.56
03/31/2023			Service Charge		1.80	1,047,642.76
03/31/2023		EOM Balance		69,504.12	115,746.34	1,047,642.76
04/03/2023	1169	Weinglass Music	Musician 4/13/23		500.00	1,047,142.76
04/06/2023	100174	Advanced Security Specialist & Consulting	Invoice: TA0032023 (Reference: Amenities security.) Invoice: T0032023B (Reference: Guard H		12,330.00	1,034,812.76
04/06/2023	100175	Integrated Access Solutions	Invoice: 0002866 (Reference: Service call response to check Amenity NVR HDD.) Invoice: 000.		528.00	1,034,284.76
04/06/2023	100176	Life Fitness	Invoice: 7337480 (Reference: Parts.) Invoice: 7336389 (Reference: Parts.)		46.86	1,034,237.90
04/06/2023	100177	Southeast Fitness	Invoice: 101452 (Reference: Semi-annually scheduled preventative maintenance.)		640.00	1,033,597.90
04/06/2023	100178	Sun State Nursery & Landscaping, Inc	Invoice: 9947 (Reference: April Landscape Maintenance.)		35,213.10	998,384.80
04/06/2023	100179	The Lake Doctors, Inc.	Invoice: 84489B (Reference: Water Management.)		1,767.00	996,617.80
04/11/2023			Deposit	192.36		996,810.16
04/11/2023			Deposit	18,840.21		1,015,650.37
04/14/2023	100180	Custom Pump & Controls, Inc.	Invoice: 23-314-02 (Reference: QUARTERLY LIFT STATION INSPECTION.)		150.00	1,015,500.37
04/14/2023	100181	Integrated Access Solutions	Invoice: 0002934 (Reference: Main Control Board & Liftmaster Motor.)		1,308.91	1,014,191.46
04/14/2023	100182	Kutak Rock LLP	Invoice: 3197846 (Reference: Beach CDD - General Counsel.)		3,028.00	1,011,163.46
04/14/2023	100183	Southeastern Paper Group	Invoice: 05870004 (Reference: Supplies.)		568.49	1,010,594.97
04/14/2023	100184	Vesta Property Services	Invoice: 409165 (Reference: Amenity Management.) Invoice: 409239 (Reference: Billable Expe		21,301.36	989,293.61
04/14/2023	100185	VGlobal Tech	Invoice: 4929 (Reference: Email hosting.)		50.00	989,243.61
04/14/2023	100186	JT's Home Solutions LLC	Invoice: 197 (Reference: Touch up painting - Fitness Room.)		750.00	988,493.61
04/17/2023	0417ACH1	JEA	Service for the month of March		21,430.34	967,063.27
04/18/2023	1170	The Perfect Pour	Event at Tamaya 4/13/23		450.00	966,613.27
04/18/2023	0418ACH1	Comcast	12788 Meritace Blvd MINI MDTA 3/28/22 - 4/27/23		548.42	966,064.85
04/19/2023	0419ACH1	TECO	12545 Beach Blvd - 2/22/23 - 3/22/23		36.35	966,028.50
04/19/2023			Deposit	3,451.56		969,480.06
04/20/2023			Deposit	54,231.04		1,023,711.10
04/20/2023	Wire042023	BNY Mellon Payment/Trustee Fees	Off Roll Assessment 2015A-1		139,418.70	884,292.40
04/20/2023	0420ACH1	Comcast	12750 Meritage Blvd. GATEHOUSE 3/30/23 - 4/29/23		216.20	884,076.20
04/20/2023			Deposit	139,406.70		1,023,482.90
04/21/2023	ACH042123	Florida Natural Gas	Fuel and Inside FGT Z3 2/23/23 - 3/22/23		10.23	1,023,472.67
04/24/2023	1171	Chance Wedderburn	BOS MTG 4/17/23		200.00	1,023,272.67
04/24/2023	1172	Matthew Calderaro	BOS MTG 4/17/23		200.00	1,023,072.67
04/24/2023	1173	Robert Renn	BOS MTG 4/17/23		200.00	1,022,872.67
04/24/2023	100187	Advanced Security Specialist & Consulting	Invoice: T0042023A (Reference: Guard House Gate Access Management.)		9,000.00	1,013,872.67
04/24/2023	100188	Big Z Pool Service, LLC	Invoice: 12240 (Reference: warranty sump pumps.)		392.00	1,013,480.67
04/24/2023	100189	Integrated Access Solutions	Invoice: 0002962 (Reference: Service Call Driveway resident entry barrier arm.) Invoice: 0002...		954.14	1,012,526.53
04/24/2023	100190	B.A.B Tennis Courts	Invoice: 1 (Reference: Tennis Center Resurfacing Project.)		5,950.00	1,006,576.53
04/24/2023	100191	Vesta District Services	Invoice: 409333 (Reference: District Management Services.)		3,958.33	1,002,618.20
04/24/2023	ACH 042423	Credit Card transactions			2,026.15	1,000,592.05
04/25/2023	0425ACH1	Comcast	12788 Meritage Blvd. OFC 4 4/3/23 - 5/2/23		361.24	1,000,230.81
04/27/2023			Deposit	1,320.00		1,001,550.81
04/30/2023			Service Charge		2.85	1,001,547.96
04/30/2023		EOM Balance		217,441.87	263,536.67	1,001,547.96
05/01/2023	1174	Chance Wedderburn	BOS Workshop 4/26/23		200.00	1,001,347.96
05/01/2023	1175	Matthew Calderaro	BOS Workshop 4/26/23		200.00	1,001,147.96

05/01/2023	1176	Robert Renn	BOS Workshop 4/26/23		200.00	1,000,947.96
05/01/2023	0501ACH1	Comcast	13077 Beach Blvd. PEDESTRIAN GATE Apr 09, 2023 to May 10, 2023		199.35	1,000,748.61
05/02/2023			Deposit	661.00		1,001,409.61
05/04/2023	100192	Magnetix DJ Services	Invoice: 3513 (Reference: Emcee & DJ Member Trivia Night.)		350.00	1,001,059.61
05/04/2023			Deposit	18,233.94		1,019,293.55
05/05/2023	100193	Advanced Security Specialist & Consulting	Invoice: T0042023B (Reference: Guard House Gate Access Management.) Invoice: TA0042023		11,520.00	1,007,773.55
05/05/2023	100194	Integrated Access Solutions	Invoice: 0003005 (Reference: Service Call.) Invoice: 0003024 (Reference: Service Call - Fitne...		411.00	1,007,362.55
05/05/2023	100195	Kutak Rock LLP	Invoice: 3211113 (Reference: General Counsel.)		1,938.00	1,005,424.55
05/05/2023	100196	TEKWave Solutions LLC	Invoice: 5684 (Reference: Visitor Management Software.)		295.00	1,005,129.55
05/05/2023	100197	The Lake Doctors, Inc.	Invoice: 91916B (Reference: Water Management.)		1,767.00	1,003,362.55
05/05/2023	100198	VGlobel Tech	Invoice: 5000 (Reference: Email hosting.)		50.00	1,003,312.55
05/05/2023	100199	SS Live Entertainment, LLC	Invoice: 2854 (Reference: Live Entertainment 4.22.23.)		500.00	1,002,812.55
05/05/2023	100200	Bouncers, Slides, and More Inc.	Invoice: 042423- (Reference: Bounce House & Obstacle Course.)		500.00	1,002,312.55
05/05/2023	100201	Beaches Electrical Service, Inc.	Invoice: 11957 (Reference: Service call on Fountain.)		125.00	1,002,187.55
05/05/2023	100202	Vesta District Services	Invoice: 409273 (Reference: Billable Expenses - March 2023.)		127.76	1,002,059.79
05/10/2023	01ACH051023	Florida Department of Health	Pool permit 16-60-1627485		325.35	1,001,734.44
05/10/2023	02ACH051023	Florida Department of Health	Pool permit 16-60-1627490		325.35	1,001,409.09
05/10/2023	03ACH051023	Florida Department of Health	Pool permit16-60-1679058		200.35	1,001,208.74
05/10/2023	0510ACH1	GFL Environmental	Trash Service		195.31	1,001,013.43
05/11/2023			Deposit	192.36		1,001,205.79
05/12/2023	1177	TEKWave Solutions LLC			1,180.00	1,000,025.79
05/12/2023	100203	Buehler Air Conditioning	Invoice: 106529 (Reference: Service Call.)		491.10	999,534.69
05/12/2023	100204	Jacksonville Daily Record	Invoice: 050423- (Reference: Advertising Supervisors Meeting.) Invoice: 041323- (Reference: .		282.76	999,251.93
05/12/2023	100205	Southeastern Paper Group	Invoice: 05895051 (Reference: Supplies.)		512.01	998,739.92
05/12/2023	100206	Sun State Nursery & Landscaping, Inc	Invoice: 10106 (Reference: Irrigation Repairs during Inspection.)		284.75	998,455.17
05/12/2023	100207	Vesta Property Services	Invoice: 410072 (Reference: Amenity Management.) Invoice: 410012 (Reference: Billable Expe		20,729.65	977,725.52
05/12/2023	100208	SS Live Entertainment, LLC	Invoice: 2860 (Reference: Live Entertainment 5/28 & 5/29/23.)		1,000.00	976,725.52
05/12/2023	100209	Trice Music Services, Inc.	Invoice: 00515 (Reference: Entertainment - May 27th.)		375.00	976,350.52
05/15/2023	1178	Chance Wedderburn	BOS Workshop 5/10/23		200.00	976,150.52
05/15/2023	1179	Matthew Calderaro	BOS Workshop 5/10/23		200.00	975,950.52
05/15/2023	1180	Robert Renn	BOS Workshop 5/10/23		200.00	975,750.52
05/15/2023	1181	Shelia Papelbon	BOS Workshop 5/10/23		200.00	975,550.52
05/16/2023			Deposit	361.00		975,911.52
05/16/2023	0516ACH1	JEA	Service for the month of April		25,925.31	949,986.21
05/18/2023	0518ACH1	Comcast	12788 Meritace Blvd MINI MDTA 4/28/22 - 5/27/23		548.20	949,438.01
05/19/2023	100210	LLS Tax Solutions, Inc.	Invoice: 003010 (Reference: Arbitrage Services.) Invoice: 003011 (Reference: Arbitrage Servic..		5,850.00	943,588.01
05/19/2023	0519ACH1	TECO	12545 Beach Blvd - 3/23/23 - 4/21/23		36.91	943,551.10
05/22/2023	1182	Chance Wedderburn	BOS Meeting 5/15/23		200.00	943,351.10
05/22/2023	1183	Matthew Calderaro	BOS Meeting 5/15/23		200.00	943,151.10
05/22/2023	1184	Robert Renn	BOS Meeting 5/15/23		200.00	942,951.10
05/22/2023	1185	Shelia Papelbon	BOS Meeting 5/15/23		200.00	942,751.10
05/22/2023	0522ACH1	Comcast	12750 Meritage Blvd. GATEHOUSE 4/30/23 - 5/29/23		216.11	942,534.99
05/23/2023	0523ACH1	Florida Natural Gas	Fuel and Inside FGT Z3 3/22/23 - 4/23/23		10.47	942,524.52
05/23/2023	ACH 052323	Credit Card transactions			2,865.90	939,658.62
05/24/2023	100211	Magnetix DJ Services	Invoice: 3514 (Reference: Trivia Night.)		350.00	939,308.62
05/25/2023	100212	10-S Tennis Supply & Dinkshot Pickleball	Invoice: 159439 (Reference: Tennis Net & Scarifler.)		347.45	938,961.17
05/25/2023	100213	Advanced Security Specialist & Consulting	Invoice: T0052023A (Reference: 05.01.23 TO 05.15.23 GUARD HOUSE GATE ACCESS MAN.		9,000.00	929,961.17
05/25/2023	100214	Integrated Access Solutions	Invoice: 0003115 (Reference: BAI Barcodes Black on Black.) Invoice: 0003117 (Reference: Cor		782.78	929,178.39
05/25/2023	100215	Vesta District Services	Invoice: 410165 (Reference: Additional Workshop Hours.) Invoice: 410183 (Reference: District		4,923.25	924,255.14
05/25/2023	100216	Lucas Tree Service, Inc.	Invoice: 8407 (Reference: Drop dead pine tree.)		500.00	923,755.14
05/25/2023	0525ACH1	Comcast	12788 Meritage Blvd. OFC 4 5/3/23 - 6/2/23		361.24	923,393.90
05/26/2023			Deposit	19,081.04		942,474.94

05/30/2023	0530ACH1	Comcast	13077 Beach Blvd. PEDESTRIAN GATE May 10, 2023 - June 09, 2023	199.35	942,275.59
05/31/2023	100217	Jacksonville Daily Record	Invoice: 052523- (Reference: Legal Advertising.)	96.50	942,179.09
05/31/2023	100218	Southeastern Paper Group	Invoice: 05909762 (Reference: Janitorial Supplies.)	375.12	941,803.97
05/31/2023	100219	TEKWave Solutions LLC	Invoice: 5753 (Reference: VMS - JUNE.)	295.00	941,508.97
05/31/2023			Service Charge	2.60	941,506.37
05/31/2023		EOM Balance		38,529.34	98,570.93
06/01/2023	100220	First Coast Fun and Games	Invoice: 5430 (Reference: Lazer Tag.)	600.00	940,906.37
06/06/2023	100221	Integrated Access Solutions	Invoice: 0003176 (Reference: BAI Barcodes Black on Black.)	383.78	940,522.59
06/06/2023	100222	Kutak Rock LLP	Invoice: 3226004 (Reference: General Counsel.)	2,574.00	937,948.59
06/06/2023	100223	TEKWave Solutions LLC	Invoice: 5750 (Reference: Remote Device Set Up.)	200.00	937,748.59
06/06/2023	100224	Lucas Tree Service, Inc.	Invoice: 8470 (Reference: Drop 4 dead trees.)	1,000.00	936,748.59
06/07/2023			Deposit	3,754.82	940,503.41
06/08/2023	100225	The Lake Doctors, Inc.	Invoice: 720157 (Reference: Water Management - Zone 1,Water Management - Zone 2.)	1,767.00	938,736.41
06/08/2023	100226	VGlobal Tech	Invoice: 5102 (Reference: Monthly email hosting.)	50.00	938,686.41
06/08/2023	0608ACH1	GFL Environmental	Trash Service	195.31	938,491.10
06/12/2023	100227	Jacksonville Daily Record	Invoice: 060823- (Reference: Legal Advertising.)	96.50	938,394.60
06/12/2023	100228	Turner Pest Control	Invoice: 617256835 (Reference: Pest Control.)	115.21	938,279.39
06/12/2023	100229	Vesta Property Services	Invoice: 410821 (Reference: Billable Expenses.)	2,093.40	936,185.99
06/12/2023	100230	B.A.B Tennis Courts	Invoice: 2 (Reference: Final Draw Tennis Center Resurfacing Project.)	5,950.00	930,235.99
06/13/2023	0613ACH1	JEA	Service for the month of May	27,905.24	902,330.75
06/14/2023			Deposit	192.36	902,523.11
06/15/2023	1186	Turner Pest Control	Pest Control	115.21	902,407.90
06/15/2023	100231	Sun State Nursery & Landscaping, Inc	Invoice: 10176 (Reference: May Landscape Maintenance.)	35,213.10	867,194.80
06/15/2023	100232	Vesta Property Services	Invoice: 410762 (Reference: Amenity Management.)	23,020.64	844,174.16
06/15/2023	100233	Vesta District Services	Invoice: 410771 (Reference: Billable Expenses - May 2023.)	149.50	844,024.66
06/15/2023			Deposit	10,319.55	854,344.21
06/20/2023	100234	Advanced Security Specialist & Consulting	Invoice: T0062023A (Reference: 06.01.23 TO 06.15.23.)	9,000.00	845,344.21
06/20/2023	100235	TEKWave Solutions LLC	Invoice: 5776 (Reference: Vehicle Passes.)	935.00	844,409.21
06/20/2023	100236	Poker Face Comedy, LLC	Invoice: 000014 (Reference: Comedian for Father's Day Brunch.)	650.00	843,759.21
06/20/2023	0620ACH1	Comcast	12750 Meritage Blvd. GATEHOUSE 5/30/23 - 6/29/23	216.11	843,543.10
06/20/2023	0620ACH2	Comcast	12788 Meritace Blvd MINI MDTA 5/28/23 - 6/27/23	546.50	842,996.60
06/20/2023	0620ACH3	TECO	12545 Beach Blvd - 4/22/23 - 5/23/23	36.91	842,959.69
06/22/2023	01ACH062223	Florida Natural Gas	Fuel and Inside FGT Z3 4/21/23-5/23/23	10.67	842,949.02
06/23/2023	100237	Advanced Security Specialist & Consulting	Invoice: T0052023B (Reference: 05.16.23 TO 05.31.23.) Invoice: T0052023 (Reference: 5/1/23	12,682.50	830,266.52
06/23/2023	100238	Southeastern Paper Group	Invoice: 05928476 (Reference: Janitorial Supplies.)	359.87	829,906.65
06/23/2023	100239	Wayne Automatic Fire Sprinklers Inc.	Invoice: 1054267 (Reference: Quarterly Sprinkler Inspection.)	75.00	829,831.65
06/23/2023	100240	Vesta District Services	Invoice: 410895 (Reference: District Management Services.)	3,958.33	825,873.32
06/23/2023	100241	Wild Wonders	Invoice: 052423- (Reference: Scaly Sensations.)	300.00	825,573.32
06/23/2023	ACH 062323	Credit Card transactions		2,005.18	823,568.14
06/26/2023	0626ACH1	Comcast	12788 Meritage Blvd. OFC 4 6/3/23 - 7/2/23	359.30	823,208.84
06/28/2023	1189	Duval's Cleanest LLC	Pressure Washing Pillars & Entrance Sign	500.00	822,708.84
06/28/2023	1190	Magnetix DJ Services	MC/DJ Member Independence Pool Party	400.00	822,308.84
06/28/2023	1191	Screening One	Screening of Trainers	180.00	822,128.84
06/28/2023	1192	Tampa Print Services, Inc.	Printing Services	539.16	821,589.68
06/29/2023			Deposit	6,561.00	828,150.68
06/30/2023	0630ACH1	Comcast	13077 Beach Blvd. PEDESTRIAN GATE June 10, 2023 - July 9, 2023	199.35	827,951.33
06/30/2023			Service Charge	1.90	827,949.43
06/20/2023	100236	Poker Face Comedy, LLC	Invoice: 000014 (Reference: Comedian for Father's Day Brunch.)	Cancelled	-650.00
06/30/2023		EOM Balance		20,827.73	134,384.67
07/01/2023	1187	BNY Mellon Tax Distributions	Tax Distributions 2013A	118,057.53	710,541.90
07/01/2023	1188	BNY Mellon Tax Distributions	Tax Distributions 2015A	51,237.53	659,304.37
07/03/2023	68		Returned NSF check #319 dated 4/25/23 Wm Revels	200.00	659,104.37

07/03/2023	68		Returned NSF check #319 dated 4/25/23 Wm Revels - check fee		10.00	659,094.37
07/05/2023	100242	Jacksonville Daily Record	Invoice: 062223- (Reference: Legal Advertising.) Invoice: 062923- (Reference: Legal Advertisi..		625.00	658,469.37
07/05/2023	100243	Kutak Rock LLP	Invoice: 3239803 (Reference: General Counsel.)		2,985.50	655,483.87
07/05/2023	100244	Southeastern Paper Group	Invoice: 05935934 (Reference: Janitorial Supplies.)		457.84	655,026.03
07/05/2023	100245	TEKWave Solutions LLC	Invoice: 5804 (Reference: VMS - JULY.)		295.00	654,731.03
07/05/2023	100246	Vesta District Services	Invoice: 411076 (Reference: District Management Services.)		3,958.33	650,772.70
07/05/2023	100247	Ancient City Hardscapes, LLC	Invoice: 2020318 (Reference: Assorted Paver Repairs.)		475.00	650,297.70
07/05/2023	100248	Nathan Pokipala	Invoice: 1235 (Reference: 4th of July Entertainment.)		1,775.00	648,522.70
07/10/2023	100249	Southeastern Paper Group	Invoice: 05938316 (Reference: Supplies.)		179.92	648,342.78
07/10/2023	100250	Vesta Property Services	Invoice: 411576 (Reference: Amenity Services.)		32,532.91	615,809.87
07/10/2023	0710ACH1	GFL Environmental	Trash Service		178.03	615,631.84
07/12/2023	100251	Advanced Security Specialist & Consulting	Invoice: T0062023 (Reference: Security @ Tamaya 6/1 - 6/30/23.)		2,450.00	613,181.84
07/12/2023	100252	Sun State Nursery & Landscaping, Inc	Invoice: 10505 (Reference: June Landscape Maintenance.)		35,213.10	577,968.74
07/12/2023	100253	The Lake Doctors, Inc.	Invoice: 106688B (Reference: Water Management.)		1,767.00	576,201.74
07/12/2023	100254	VGlobal Tech	Invoice: 5218 (Reference: Email hosting.)		50.00	576,151.74
07/12/2023	100255	All Weather Contractors, Inc.	Invoice: 161697 (Reference: Plumbing Call Floor Drain Fitness Center.)		195.00	575,956.74
07/14/2023	100256	Advanced Security Specialist & Consulting	Invoice: T0062023B (Reference: 06.16.23 TO 06.30.23.)		9,300.00	566,656.74
07/14/2023	100257	Integrated Access Solutions	Invoice: 0003448 (Reference: Service Call.)		132.00	566,524.74
07/18/2023			Deposit	4,175.00		570,699.74
07/18/2023			Deposit	7,875.00		578,574.74
07/18/2023	0718ACH1	Comcast	12788 Meritace Blvd MINI MDTA 6/28/23 - 7/27/23		550.50	578,024.24
07/18/2023	0718ACH2	JEA	Service for the month of June		30,205.87	547,818.37
07/19/2023	1193	Maximum Entertainment Trivia	Monthly Trivia July 20th		200.00	547,618.37
07/19/2023	0719ACH1	TECO	12545 Beach Blvd - 5/24/23 - 6/22/23		36.35	547,582.02
07/19/2023			Account Closing Transfer	100.00		547,682.02
07/20/2023	0720ACH1	Comcast	12750 Meritage Blvd. GATEHOUSE 6/30/23 - 7/29/23		217.11	547,464.91
07/24/2023	0724ACH1	Florida Natural Gas	Fuel and Inside FGT Z3 5/23/23 - 6/22/23		10.28	547,454.63
07/24/2023	0724CC1	Credit Card transactions			2,464.79	544,989.84
07/25/2023			Deposit	192.36		545,182.20
07/25/2023	0725ACH1	Comcast	12788 Meritage Blvd. OFC 4 Jul 03, 2023 to Aug 02, 2023		359.30	544,822.90
07/26/2023	1194	Frederick Marshall Moore	Refund of Reservation		700.00	544,122.90
07/26/2023	1195	Chance Wedderburn	BOS Meeting 7/17/23		200.00	543,922.90
07/26/2023	1196	Elena Korsakova	BOS Meeting 7/17/23		200.00	543,722.90
07/26/2023	1197	Matthew Calderaro	BOS Meeting 7/17/23		200.00	543,522.90
07/26/2023	1198	Robert Renn	BOS Meeting 7/17/23		200.00	543,322.90
07/26/2023	1199	Shelia Papelbon	BOS Meeting 7/17/23		200.00	543,122.90
07/26/2023	100258	Advanced Security Specialist & Consulting	Invoice: T0072023A (Reference: 07.01.23 TO 07.15.23.)		9,300.00	533,822.90
07/26/2023	100259	Custom Pump & Controls, Inc.	Invoice: 51318 (Reference: COJ OWNERS SIGN.) Invoice: 23-314-03 (Reference: QUARTERI		445.63	533,377.27
07/26/2023	100260	Integrated Access Solutions	Invoice: 0003505 (Reference: BAI Barcodes Black on Black.)		383.78	532,993.49
07/26/2023	100261	Southeastern Paper Group	Invoice: 05946343 (Reference: Supplies.)		398.05	532,595.44
07/26/2023	100262	TEKWave Solutions LLC	Invoice: 5848 (Reference: VMS - August.)		295.00	532,300.44
07/31/2023	0731ACH1	Comcast	13077 Beach Blvd. PEDESTRIAN GATE July 10, 2023 - Aug 9, 2023		199.35	532,101.09
07/31/2023			Service Charge		1.60	532,099.49
7/31/2023		EOM Balance			12,342.36	308,842.30
08/01/2023	100263	Vesta District Services	Invoice: 411747 (Reference: District Management Services.)		3,958.33	528,141.16
08/02/2023			Deposit	54,231.04		582,372.20
08/03/2023			Deposit	2,680.00		585,052.20
08/04/2023	100264	Southeast Fitness	Invoice: 102279 (Reference: Diagnosis of Rear Delt Machine.)		179.83	584,872.37
08/04/2023	100265	Southeastern Paper Group	Invoice: 05953385 (Reference: Janitorial Supplies.)		243.07	584,629.30
08/04/2023	100266	The Lake Doctors, Inc.	Invoice: 113881B (Reference: Water Management.)		1,767.00	582,862.30
08/04/2023	100267	VGlobal Tech	Invoice: 5292 (Reference: Email hosting.)		50.00	582,812.30
08/07/2023	100268	Advanced Security Specialist & Consulting	Invoice: T0072023B (Reference: 07.16.23 TO 07.31.23 guard service.) Invoice: T0072023 (Refi		11,805.00	571,007.30

08/09/2023	100269	Jacksonville Daily Record	Invoice: 080323- (Reference: Board of Supervisors Meeting.)	110.00	570,897.30
08/09/2023	100270	Kutak Rock LLP	Invoice: 3264063 (Reference: General Legal Matters.)	365.00	570,532.30
08/09/2023	100271	Magnetix DJ Services	Invoice: 3520 (Reference: Outdoor Teen Foam Party.)	275.00	570,257.30
08/09/2023	100272	Leisure Creations	Invoice: 00078396 (Reference: Replacement Seat Sling.)	499.52	569,757.78
08/09/2023	100273	Dibartolomeo, McBee, Hartley & Barnes, PA	Invoice: 90093309 (Reference: CPA Services FYE 09.30.22.)	3,250.00	566,507.78
08/09/2023	100274	The Jacksonville Party Company	Invoice: 07292023.07 (Reference: "Welcome to Vegas" Party.)	3,002.10	563,505.68
08/09/2023	0809ACH1	GFL Environmental	Trash Service	178.03	563,327.65
08/11/2023			Deposit	192.36	563,520.01
08/14/2023	100275	Jacksonville Daily Record	Invoice: 081023- (Reference: Legal Advertising.)	99.88	563,420.13
08/14/2023	100276	Vesta Property Services	Invoice: 412318 (Reference: Amenity Management.) Invoice: 412392 (Reference: Billable Expe	41,435.59	521,984.54
08/14/2023	100277	Maximum Entertainment	Invoice: 2 (Reference: Trivia 8.18.23.)	200.00	521,784.54
08/15/2023	100278	Big Z Pool Service, LLC	Invoice: 12679 (Reference: Black Algae Scrub.)	1,780.00	520,004.54
08/15/2023	100279	Integrated Access Solutions	Invoice: 0003605 (Reference: Move Antenna.) Invoice: 0003606 (Reference: 5 Port PoE switch	532.98	519,471.56
08/15/2023	100280	Vesta District Services	Invoice: 411642 (Reference: Billable Expenses - June 2023.)	11.40	519,460.16
08/15/2023	100281	Lucas Tree Service, Inc.	Invoice: 8867 (Reference: Drop 4 dead pine trees.)	1,000.00	518,460.16
08/16/2023	100282	Bouncers, Slides, and More Inc.	Invoice: 08112023.11 (Reference: Bounce House & Obstacle Course.)	500.00	517,960.16
08/16/2023	0816ACH1	JEA	Service for the month of July	28,065.77	489,894.39
08/17/2023	1201	KS State Bank	3361927	1,539.95	488,354.44
08/17/2023	1202	KS State Bank	3361927	1,539.95	486,814.49
08/18/2023	100283	Southeastern Paper Group	Invoice: 05967335 (Reference: Paper Supplies.)	468.19	486,346.30
08/18/2023	100284	First Coast Foam Party LLC	Invoice: 2023-08-11-03 (Reference: Glow party 8/11/23.)	1,050.00	485,296.30
08/18/2023	0818ACH1	TECO	12545 Beach Blvd - 6/23/23 - 7/20/23	36.35	485,259.95
08/18/2023	018ACH1	Comcast	12788 Meritace Blvd MINI MDTA 7/28/23 - 8/27/23	544.45	484,715.50
08/21/2023			Deposit	3,787.00	488,502.50
08/21/2023	0821ACH1	Comcast	12750 Meritage Blvd. GATEHOUSE Jul 30, 2023 to Aug 29, 2023	215.92	488,286.58
08/22/2023	0822ACH1	Florida Natural Gas	Fuel and Inside FGT Z3 6/22/23 - 7/20/23	10.79	488,275.79
08/23/2023	1203	Magnetix DJ Services	Outdoor Carnival	400.00	487,875.79
08/23/2023	ACH 082323	Credit Card transactions		2,817.25	485,058.54
08/23/2023	69		Resident bounced check	700.00	484,358.54
08/23/2023	69		Resident bounced check fee	10.00	484,348.54
08/24/2023	100285	Advanced Security Specialist & Consulting	Invoice: T0082023A (Reference: 08.01.23 TO 08.15.23.)	9,000.00	475,348.54
08/24/2023	100286	Big Z Pool Service, LLC	Invoice: 12680 (Reference: Black Algae Scrub family pool.)	1,980.00	473,368.54
08/24/2023	100287	Integrated Access Solutions	Invoice: 0003711 (Reference: Service Call Entry Arm.)	188.43	473,180.11
08/24/2023	100288	All Weather Contractors, Inc.	Invoice: 165174 (Reference: Installed Faucet & adjusted flush valves.) Invoice: 165333 (Refer...	2,461.25	470,718.86
08/25/2023	1200	Gabriele M. Beyer	Refund from Lost Keycard found	25.00	470,693.86
08/25/2023	825ACH1	Comcast	12788 Meritage Blvd. OFC 4 Aug 03, 2023 to Sep 02, 2023	359.30	470,334.56
08/28/2023	1205	Elena Korsakova	BOS Meeting 8/21/23	200.00	470,134.56
08/28/2023	1206	Matthew Calderaro	BOS Meeting 8/21/23	200.00	469,934.56
08/28/2023	1207	Robert Renn	BOS Meeting 8/21/23	200.00	469,734.56
08/29/2023			Deposit	1,000.00	470,734.56
08/29/2023	100289	Buehler Air Conditioning	Invoice: 114952 (Reference: Commercial Diagnostic.)	129.00	470,605.56
08/29/2023	100290	TEKWave Solutions LLC	Invoice: 5932 (Reference: VMS - SEPT.)	295.00	470,310.56
08/30/2023	0830ACH1	Comcast	13077 Beach Blvd. PEDESTRIAN GATE Aug 10, 2023 to Sep 09, 2023	199.35	470,111.21
08/31/2023			Deposit	1,980.08	472,091.29
08/31/2023			Service Charge	2.40	472,088.89
8/31/2023		EOM Balance		63,870.48	123,881.08
09/05/2023	100291	Vesta District Services	Invoice: 412517 (Reference: Management Services.)	3,958.33	468,130.56
09/05/2023	100292	J.C. Pappas Ent Inc.	Invoice: 241 (Reference: Live music show 9/9/23.)	1,800.00	466,330.56
09/06/2023	100293	Advanced Security Specialist & Consulting	Invoice: T0082023 (Reference: Amenity Security - August.) Invoice: T0082023B (Reference: Gi	11,700.00	454,630.56
09/06/2023	100294	Buehler Air Conditioning	Invoice: 115001 (Reference: HVAC Maint..)	2,061.00	452,569.56
09/06/2023	100295	Integrated Access Solutions	Invoice: 0003753 (Reference: Gate service call.)	164.00	452,405.56
09/06/2023	100296	Kutak Rock LLP	Invoice: 3268637 (Reference: Legal Services - July.)	1,925.00	450,480.56

09/06/2023	100297	Onsight Industries LLC	Invoice: 002-23-34-347905-1 (Reference: Signage.)	374.00	450,106.56
09/06/2023	100298	The Lake Doctors, Inc.	Invoice: 121562B (Reference: lake maint. Sept.)	1,767.00	448,339.56
09/06/2023	100299	VGlobal Tech	Invoice: 5387 (Reference: website hosting Sept..)	50.00	448,289.56
09/07/2023			Deposit	5,515.00	453,804.56
09/08/2023	0908ACH1	GFL Environmental	Trash Service	229.87	453,574.69
09/11/2023	1209	Shelia Papelbon	BOS Meeting 8/21/23	200.00	453,374.69
09/12/2023	10024477	Vesta Property Services, Inc.		2,820.00	456,194.69
09/13/2023	100300	E.T.M.	Invoice: 0205815 (Reference: Engineering Services thru 11/26/22.)	1,083.75	455,110.94
09/13/2023	100301	Jacksonville Daily Record	Invoice: 23-06055D (Reference: Legal Advertising.) Invoice: 23-06056D (Reference: Legal Adv	152.51	454,958.43
09/13/2023	100302	Vesta Property Services	Invoice: 413246 (Reference: Billable Expenses.)	3,957.12	451,001.31
09/13/2023	100303	Wayne Automatic Fire Sprinklers Inc.	Invoice: 1071749 (Reference: Annual Sprinkler & Alarm inspection.)	309.38	450,691.93
09/13/2023	100304	Florida Backyard by Ebel, Inc	Invoice: 31035 (Reference: Outdoor furniture.)	13,822.08	436,869.85
09/13/2023	1210	Brenna & Christopher Morgan	Pool Cabana Deposit Refund 7.18.23	150.00	436,719.85
09/14/2023	0914ACH1	JEA	Service for the month of August	25,722.17	410,997.68
09/15/2023	1211	Screening One	Screening of Trainer	38.00	410,959.68
09/15/2023	100305	Buehler Air Conditioning	Invoice: 116088 (Reference: Commercial Diagnostic.)	508.00	410,451.68
09/15/2023	100306	Southeast Fitness	Invoice: 102573 (Reference: Semi-annually scheduled preventative maintenance.)	640.00	409,811.68
09/15/2023	100307	Southeastern Paper Group	Invoice: 05988268 (Reference: Janitorial Supplies.)	444.24	409,367.44
09/15/2023	100308	The Tree Amigos Outdoor Services, Inc.	Invoice: 200822 (Reference: Repairs made during Irrigation System Inspection.) Invoice: 20129.	7,850.00	401,517.44
09/18/2023	0918ACH1	TECO	12545 Beach Blvd - 7/21/23 - 8/18/23	36.97	401,480.47
09/18/2023	091823ACH1	Comcast	12788 Meritace Blvd MINI MDTA 8/28/23 - 9/27/23	548.18	400,932.29
09/20/2023	0920ACH1	Comcast	12750 Meritage Blvd. GATEHOUSE Aug 30, 2023 to Sep 29, 2023	216.85	400,715.44
09/21/2023			Deposit	192.36	400,907.80
09/21/2023			Deposit	901.88	401,809.68
09/21/2023	0921ACH1	Florida Natural Gas	Fuel and Inside FGT Z3 7/21/23 - 8/21/23	11.35	401,798.33
09/25/2023	1213	Chance Wedderburn	BOS Meeting 9/18/23	200.00	401,598.33
09/25/2023	1214	Elena Korsakova	BOS Meeting 9/18/23	200.00	401,398.33
09/25/2023	1215	Robert Renn	BOS Meeting 9/18/23	200.00	401,198.33
09/25/2023	1216	Shelia Papelbon	BOS Meeting 9/18/23	200.00	400,998.33
09/25/2023	100309	10-S Tennis Supply & Dinkshot Pickleball	Invoice: 160967 (Reference: Light Bulbs.)	160.19	400,838.14
09/25/2023	100310	Advanced Security Specialist & Consulting	Invoice: T0092023A (Reference: Guard House Gate Access September 1, 2023 - September 15, 20	9,300.00	391,538.14
09/25/2023	100311	Integrated Access Solutions	Invoice: 0003900 (Reference: BAI Barcodes Black on Black.)	383.78	391,154.36
09/25/2023	100312	Jacksonville Daily Record	Invoice: 091423- (Reference: Legal Advertising.)	143.75	391,010.61
09/25/2023	100313	Vesta Property Services	Invoice: 413222 (Reference: Amenity Management.)	27,974.49	363,036.12
09/25/2023	100314	Vesta District Services	Invoice: 412400 (Reference: Billable Expenses - Jul 2023.) Invoice: 413158 (Reference: Billab...	86.34	362,949.78
09/25/2023	100315	Maximum Entertainment	Invoice: 3 (Reference: Karaoke 9.22.23.)	250.00	362,699.78
09/25/2023	100316	Ramon Cruz	Invoice: 101 (Reference: Music on the Patio.)	500.00	362,199.78
09/25/2023	100317	The Tree Amigos Outdoor Services, Inc.	Invoice: 201223 (Reference: Refresh all flower beds.)	500.00	361,699.78
09/25/2023	0925ACH1	Comcast	12788 Meritage Blvd. OFC 4 Sep 03, 2023 to Oct 02, 2023	359.30	361,340.48
09/25/2023	ACH 092523	Credit Card transactions		3,599.43	357,741.05
09/27/2023	1217	BNY Mellon Tax Distributions	Tax Distributions 2013A	4,375.72	353,365.33
09/27/2023	1218	BNY Mellon Tax Distributions	Tax Distributions 2015A	2,011.23	351,354.10
09/28/2023	100318	Integrated Access Solutions	Invoice: 0003917 (Reference: Troubleshoot motor pulley slipping.)	188.43	351,165.67
09/30/2023			Service Charge	31.85	351,133.82
9/30/2023		EOY Balance		9,429.24	130,384.31
					351,133.82

EXHIBIT 6

Beach
Community Development District

Financial Statements
(Unaudited)

Preliminary

October 31, 2023

Beach CDD
Balance Sheet
October 31, 2023

	General Fund	Reserve Fund	Debt Service 2013A	Debt Service 2015A	Construction	Total
1 ASSETS						
2 OPERATING ACCOUNT BU	\$ 267,815	\$ -	\$ -	\$ -	\$ -	\$ 267,815
3 PAYPAL ACCOUNT BU	-	-	-	-	-	-
4 CHECKING ACCOUNT CS	49,243	-	-	-	-	49,243
5 DEBT CARD ACCOUNT CS	893	-	-	-	-	893
6 DEBT SERVICE ACCOUNTS:						
7 SINKING FUND	-	-	-	-	-	-
8 INTEREST FUND	-	-	305,035	217,120	-	522,155
9 REDEMPTION FUND	-	-	37	150	-	187
10 PREPAYMENT FUND	-	-	65,942	113,048	-	178,990
11 REVENUE FUND	-	-	142,478	5,935	-	148,413
12 OP REDEMPTION FUND	-	-	-	-	-	-
13 ACQ & CONS 2013A	-	-	-	-	-	-
14 ACQ & CONS 2015A	-	-	-	-	-	-
15 ACCOUNTS RECEIVABLE	700	-	-	-	-	700
16 ASSESSMENTS RECEIVABLE ON-ROLL	1,699,665	86,878	791,231	365,292	-	2,943,065
17 ASSESSMENTS RECEIVABLE OFF-ROLL	256,709	13,122	-	327,167	-	596,998
18 DUE FROM OTHER FUNDS	12,761	-	-	-	-	12,761
19 PREPAID	3,966	-	-	-	-	3,966
20 TOTAL ASSETS	\$ 2,291,752	\$ 100,000	\$ 1,304,724	\$ 1,028,710	\$ -	\$ 4,725,186
21 LIABILITIES						
22 ACCOUNTS PAYABLE	\$ 35,798	\$ -	\$ -	\$ -	\$ -	\$ 35,798
23 DEFERRED REVENUE ON-ROLL	1,699,665	86,878	791,231	365,292	-	2,943,065
24 DEFERRED REVENUE OFF-ROLL	256,709	13,122	-	327,167	-	596,998
25 DUE TO OTHER FUNDS	-	12,761	-	-	-	12,761
26 OUTSTANDING CHECKS	-	-	-	-	-	-
27 TOTAL LIABILITIES	1,992,172	112,761	791,231	692,458	-	3,588,622
28 FUND BALANCE						
29 NONSPENDABLE						
30 PREPAID & DEPOSITS	3,966	-	-	-	-	3,966
31 CAPITAL RESERVES	109,319	-	-	-	-	109,319
32 OPERATING CAPITAL	-	-	-	-	-	-
33 UNASSIGNED	186,295	(12,761)	513,493	336,252	-	1,023,279
34 TOTAL FUND BALANCE	299,580	(12,761)	513,493	336,252	-	1,136,564
35 TOTAL LIABILITIES & FUND BALANCE	\$ 2,291,752	\$ 100,000	\$ 1,304,724	\$ 1,028,710	\$ -	\$ 4,725,186

Beach CDD
General Fund
Statement of Revenue, Expenditures, and Changes in Fund Balance
For the period from October 1, 2023 to October 31, 2023

	FY 2024 Adopted Budget	FY 2024 Month of October	FY 2024 Total Actual Year-to-Date	VARIANCE Over (Under) to Budget	% Actual YTD / FY Budget
1 REVENUE					
2 ASSESSMENTS ON-ROLL	\$ 1,699,665	\$ -	\$ -	\$ (1,699,665)	0%
3 ASSESSMENTS OFF-ROLL	256,709	67,458	67,458	(189,252)	26%
4 INTEREST REVENUE	-	3	3	3	
5 OTHER FINANCING SOURCES	-	3,107	3,107	3,107	
6 TOTAL REVENUE	\$ 1,956,374	\$ 70,569	\$ 70,569	\$ (1,885,805)	4%
7 EXPENDITURES					
8 GENERAL & ADMINISTRATIVE EXPENSES					
9 TRUSTEE FEES	\$ 9,500	\$ -	\$ -	\$ (9,500)	0%
10 SUPERVISOR FEES-REGULAR MEETINGS	12,000	1,000	1,000	(11,000)	8%
11 SUPERVISOR FEES-WORKSHOPS	2,000	600	600	(1,400)	30%
12 DISTRICT MANAGEMENT	43,680	4,117	4,117	(39,563)	9%
13 ENGINEERING	5,000	-	-	(5,000)	0%
14 DISSEMINATION AGENT	2,600	2,600	2,600	-	100%
15 DISTRICT COUNSEL	18,000	4,406	4,406	(13,594)	24%
16 ASSESSMENT ADMINISTRATION	5,720	-	-	(5,720)	0%
17 ARBITRAGE REBATE CALCULATION	3,300	-	-	(3,300)	0%
18 AUDIT	3,450	-	-	(3,450)	0%
19 WEBSITE	2,150	1,565	1,565	(585)	73%
20 LEGAL ADVERTISING	7,000	190	190	(6,810)	3%
21 DUES, LICENSES & FEES	175	-	-	(175)	0%
22 GENERAL LIABILITY INSURANCE	129,560	72,332	72,332	(57,228)	56%
23 OFFICE MISCELLANEOUS	3,500	3	3	(3,497)	0%
24 DISTRICT CONTINGENCY	150,000	-	-	(150,000)	0%
25 TOTAL GENERAL & ADMINISTRATIVE EXPENSES	397,635	86,812	86,812	(310,823)	22%
26 FIELD EXPENSES					
27 FIELD MANAGEMENT	139,333	-	-	(139,333)	0%
28 LAKE MAINTENANCE	23,500	1,767	1,767	(21,733)	8%
29 LANDSCAPING (INCLUDING MATERIALS)	389,046	-	-	(389,046)	0%
30 MULCH AND PINE STRAW	32,000	-	-	(32,000)	0%
31 IRRIGATION (REPAIRS)	4,000	-	-	(4,000)	0%
32 UTILITIES/SEWERS/PROPANE GAS	291,000	199	199	(290,801)	0%
33 CONTINGENCY - HURRICANE / STORM CLEAN UP	8,000	-	-	(8,000)	0%
34 COMMUNITY MAINTENANCE	8,000	2,500	2,500	(5,500)	31%
35 TOTAL FIELD EXPENSES	894,879	4,466	4,466	(890,413)	0%

36	AMENITY EXPENSES					
37	AMENITY MANAGEMENT	128,551	-	-	(128,551)	0%
38	LIFEGUARD	23,305	-	-	(23,305)	0%
39	AMENITY/FITNESS CENTER STAFFING	73,000	-	-	(73,000)	0%
40	SWIMMING POOL CHEMICALS	28,600	-	-	(28,600)	0%
41	POOL/ENTRY WATER FEATURE MAINTENANCE	25,529	-	-	(25,529)	0%
42	SWIMMING POOL INSPECTION	850	-	-	(850)	0%
43	AMENITY GENERAL MAINTENANCE & REPAIRS	21,000	1,358	1,358	(19,642)	6%
44	HOLIDAY DECORATIONS	10,000	-	-	(10,000)	0%
45	AMENITY CLEANING	24,000	1,388	1,388	(22,612)	6%
46	AMENITY GATES/CONTROL ACCESS	12,000	295	295	(11,705)	2%
47	AMENITY GATE REPAIRS	4,000	326	326	(3,674)	8%
48	AMENITY WEBSITE/COMPUTER EQUIPMENT	1,700	-	-	(1,700)	0%
49	AMENITY INTERNET/CABLE	15,000	359	359	(14,641)	2%
50	FITNESS EQUIPMENT LEASE	16,000	-	-	(16,000)	0%
51	LIFESTYLES PROGRAMMING	33,000	-	-	(33,000)	0%
52	TENNIS COURT MAINTENANCE - 4 CLAY COURTS	2,500	-	-	(2,500)	0%
53	LANDSCAPE IMPROVEMENT	2,500	-	-	(2,500)	0%
54	PEST CONTROL	1,600	115	115	(1,485)	7%
55	AMENITY FIRE SYSTEM MONITORING	1,425	-	-	(1,425)	0%
56	TRASH COLLECTION	2,300	195	195	(2,105)	8%
57	TOTAL AMENITY EXPENSES	426,860	4,037	4,037	(422,823)	1%
58	ACCESS CONTROL /GATE HOUSE					
59	GUARD SERVICE	232,000	20,520	20,520	(211,480)	9%
60	BAR CODE EXPENSE	5,000	384	384	(4,616)	8%
61	TOTAL ACCESS CONTROL/GATE HOUSE EXPENSES	237,000	20,904	20,904	(216,096)	9%
62	TOTAL EXPENDITURES	1,956,374	116,219	116,219	(1,840,155)	6%
63	EXCESS OF REVENUE OVER (UNDER) EXPENDITURES	-	(45,650)	(45,650)	(45,650)	
64	OTHER FINANCING SOURCES & USES					
65	TRANSFER IN	-	-	-	-	
66	TRANSFER OUT	-	-	-	-	
67	TOTAL OTHER FINANCING SOURCES & USES	-	-	-	-	
68	FUND BALANCE - BEGINNING	238,292		235,911	(2,381)	
69	NET CHANGE IN FUND BALANCE	-	(45,650)	(45,650)	(45,650)	
70	FUND BALANCE - ENDING	\$ 238,292		\$ 190,261	\$ (48,031)	
71	ANALYSIS OF FUND BALANCE					
72	NONSPENDABLE					
73	PREPAID & DEPOSITS	886		3,966		
74	CAPITAL RESERVES	109,319		109,319		
75	OPERATING CAPITAL	-		-		
76	UNASSIGNED	128,087		186,295		
77	TOTAL FUND BALANCE	\$ 238,292		\$ 299,580		

Beach CDD
Capital Reserve Fund (CRF)
Statement of Revenue, Expenditures, and Changes in Fund Balance
For the period from October 1, 2023 to October 31, 2023

	FY 2024 Amended Budget	FY 2024 Total Actual Year-to-Date	VARIANCE Over (Under) to Budget
1 REVENUE			
2 ASSESSMENTS ON-ROLL	\$ 86,878	\$ -	\$ (86,878)
3 ASSESSMENTS OFF-ROLL	13,122	-	(13,122)
4 INTEREST & MISCELLANEOUS	-	-	-
5 TOTAL REVENUE	100,000	-	(100,000)
6 EXPENDITURES			
7 CAPITAL IMPROVEMENT PLAN (CIP)	-	9,325	9,325
8 CONTINGENCY	-	3,437	3,437
9 TOTAL EXPENDITURES	-	12,761	12,761
10 EXCESS OF REVENUE OVER (UNDER) EXPENDITURES	100,000	(12,761)	(112,761)
11 OTHER FINANCING SOURCES & USES			
12 TRANSFERS IN	-		
13 TRANSFERS OUT	-	-	
14 TOTAL OTHER FINANCING SOURCES & USES	-	-	-
15 FUND BALANCE - BEGINNING	-		-
16 NET CHANGE IN FUND BALANCE	100,000	(12,761)	(112,761)
17 FUND BALANCE - ENDING	\$ 100,000	\$ (12,761)	\$ (112,761)
18 ANALYSIS OF FUND BALANCE			
19 ASSIGNED			
20 FUTURE CAPITAL IMPROVEMENTS			
21 WORKING CAPITAL			
22 UNASSIGNED	100,000	(12,761)	
23 FUND BALANCE - ENDING	\$ 100,000	\$ (12,761)	

Beach CDD
Debt Service 2013A
Statement of Revenue, Expenditures, and Changes in Fund Balance
For the period from October 1, 2023 to October 31, 2023

	FY 2024 Adopted Budget	FY 2024 Actual Year-to-Date	VARIANCE Over (Under) to Budget
1 REVENUE			
2 ASSESSMENTS ON-ROLL	\$ 795,300	\$ -	\$ (795,300)
3 ASSESSMENTS OFF-ROLL	-	-	-
4 INTEREST REVENUE	-	1,497	1,497
5 MISC. REVENUE	-	-	-
6 TOTAL REVENUE	795,300	1,497	(793,803)
7 EXPENDITURES			
8 INTEREST EXPENSE			
9 November 1, 2023	-	-	-
10 May 1, 2024	305,575	-	(305,575)
11 November 1, 2024	299,378	-	(299,378)
12 PRINCIPAL RETIREMENT			
13 May 1, 2024	185,000	-	(185,000)
14 PRINCIPAL PREPAYMENT	-	-	-
15 TOTAL EXPENDITURES	789,953	-	789,953
16 EXCESS OF REVENUE OVER (UNDER) EXPENDITURES	5,348	1,497	(3,851)
17 OTHER FINANCING SOURCES (USES)			
18 TRANSFER IN	-	-	-
19 TRANSFER OUT (USES)	-	-	-
20 TOTAL OTHER FINANCING SOURCES (USES)	-	-	-
21 FUND BALANCE - BEGINNING	511,997	511,997	-
22 NET CHANGE IN FUND BALANCE	5,348	1,497	(3,851)
23 FUND BALANCE - ENDING	\$ 517,344	\$ 513,493	\$ (3,851)

Beach CDD
Debt Service 2015A
Statement of Revenue, Expenditures, and Changes in Fund Balance
For the period from October 1, 2023 to October 31, 2023

	FY 2024 Adopted Budget	FY 2024 Actual Year-to-Date	VARIANCE Over (Under) to Budget
1 REVENUE			
2 ASSESSMENTS ON-ROLL	\$ 365,292	\$ -	\$ (365,292)
3 ASSESSMENTS OFF-ROLL	234,228	92,938	(141,290)
4 INTEREST REVENUE	-	369	369
5 MISC. REVENUE	-	32,936	32,936
6 TOTAL REVENUE	599,520	126,242	(473,278)
7 EXPENDITURES			
8 INTEREST EXPENSE			
9 November 1, 2023	-	-	-
10 May 1, 2024	217,268	-	(217,268)
11 November 1, 2024	212,253	-	(212,253)
12 PRINCIPAL RETIREMENT			
13 May 1, 2024	170,000	-	(170,000)
14 PRINCIPAL PREPAYMENT	-	-	-
15 TOTAL EXPENDITURES	599,520	-	599,520
16 EXCESS OF REVENUE OVER (UNDER) EXPENDITURES	-	126,242	126,242
17 OTHER FINANCING SOURCES (USES)			
18 TRANSFER IN	-	-	-
19 TRANSFER OUT (USES)	-	-	-
20 TOTAL OTHER FINANCING SOURCES (USES)	-	-	-
21 FUND BALANCE - BEGINNING	210,010	210,010	-
22 NET CHANGE IN FUND BALANCE	-	126,242	126,242
23 FUND BALANCE - ENDING	\$ 210,010	\$ 336,252	\$ 126,242

Beach CDD Check Register - FY2024

Date	Ref. Num	Name	Memo	Deposits	Disbursements	Balance
09/30/2023		EOY Balance				351,133.82
10/01/2023	1219	Egis Insurance and Risk Advisors	FY Insurance Policy # 100123192 10/01/23-10/01/24		278,801.82	278,801.82
10/02/2023	1002ACH1	Comcast	13077 Beach Blvd. PEDESTRIAN GATE Sep 10, 2023 to Oct 09, 2023		199.35	278,602.47
10/03/2023	100319	Advanced Security Specialist & Consulting	Invoice: T0092023B (Reference: 09.16.23 TO 09.30.23 Security.) Invoice: T0092023 (Referenc		11,520.00	267,082.47
10/03/2023	100320	Innersync	Invoice: 21751 (Reference: Website Services.)		1,515.00	265,567.47
10/03/2023	100321	The Lake Doctors, Inc.	Invoice: 128865B (Reference: Water Management Zone 1 & 2.)		1,767.00	263,800.47
10/03/2023	100322	Vesta District Services	Invoice: 413498 (Reference: District Management Services.) Invoice: 413499 (Reference: Annu:		6,716.67	257,083.80
10/04/2023	100323	VGlobal Tech	Invoice: 5502 (Reference: Email hosting.)		50.00	257,033.80
10/06/2023	1220	Turner Pest Control			345.63	256,688.17
10/11/2023	1011ACH1	GFL Environmental	Trash Service		195.31	256,492.86
10/12/2023	100324	Jacksonville Daily Record	Invoice: 23-06605D (Reference: Legal Advertising.)		96.50	256,396.36
10/12/2023	100325	Kutak Rock LLP	Invoice: 3292492 (Reference: Legal services for August.)		1,975.00	254,421.36
10/17/2023			Deposit	192.36		254,613.72
10/17/2023			Deposit	2,200.00		256,813.72
10/17/2023	100326	Buehler Air Conditioning	Invoice: 117878 (Reference: Leak Check.) Invoice: 117745 (Reference: - Commercial Diagnosti		921.00	255,892.72
10/17/2023	100327	Custom Pump & Controls, Inc.	Invoice: 23-314-04 (Reference: QUARTERLY LIFT STATION INSPECTION.)		150.00	255,742.72
10/17/2023	100328	Integrated Access Solutions	Invoice: 0004071 (Reference: BAI Barcodes Black on Black.)		383.78	255,358.94
10/17/2023	100329	Jacksonville Daily Record	Invoice: 23-06781D (Reference: Legal Advertising.)		93.13	255,265.81
10/17/2023	100330	Southeastern Paper Group	Invoice: 06009873 (Reference: Janitorial Supplies.)		437.00	254,828.81
10/17/2023	100331	Lucas Tree Service, Inc.	Invoice: 9150 (Reference: Remove Pine Trees.)		1,000.00	253,828.81
10/17/2023	1017ACH1	JEA	Service for the month of September		22,662.66	231,166.15
10/18/2023	1018ACH1	Turner Pest Control	Pest Control		115.21	231,050.94
10/18/2023	1018ACH2	Comcast	12788 Meritace Blvd MINI MDTA Sep 28, 2023 to Oct 27, 2023		548.45	230,502.49
10/19/2023	100332	Advanced Security Specialist & Consulting	Invoice: T0102023A (Reference: October 1, 2023 - October 15, 2023 Guard Gate.)		9,000.00	221,502.49
10/19/2023	100333	Vesta District Services	Invoice: 414258 (Reference: Billable Expenses - Sep 2023.)		69.13	221,433.36
10/19/2023	100334	Jani-King of Jacksonville	Invoice: JAK10230486 (Reference: Commercial Cleaning.)		1,387.84	220,045.52
10/19/2023	1019ACH1	TECO	12545 Beach Blvd - 8/18/23 - 9/20/23		36.97	220,008.55
10/19/2023	1019ACH2	Turner Pest Control	Pest Control		115.21	219,893.34
10/20/2023	1020ACH1	Comcast	12750 Meritage Blvd. GATEHOUSE Sep 30, 2023 to Oct 29, 2023		238.20	219,655.14
10/23/2023	ACH102323	Florida Natural Gas	Fuel and Inside FGT Z3 8/18/23 - 9/20/23		11.37	219,643.77
10/23/2023	100335	Integrated Access Solutions	Invoice: 0004107 (Reference: Direct ALL-IN-ONE OEM replacement.) Invoice: 0004108 (Refer		6,490.28	213,153.49
10/23/2023	100336	Vesta District Services	Invoice: 414351 (Reference: Excess Meetings Held FY2023.)		1,600.00	211,553.49
10/23/2023	ACH 102323	Credit Card transactions			2,138.42	209,415.07
10/24/2023	1221	Chance Wedderburn	BOS Meeting 10/16/23		200.00	209,215.07
10/24/2023	1222	Elena Korsakova	BOS Meeting 10/16/23		200.00	209,015.07
10/24/2023	1223	Matthew Calderaro	BOS Meeting 10/16/23		200.00	208,815.07
10/24/2023	1224	Robert Renn	BOS Meeting 10/16/23		200.00	208,615.07
10/24/2023	1225	Shelia Papelbon	BOS Meeting 10/16/23		200.00	208,415.07
10/25/2023			Deposit	67,457.77		275,872.84
10/25/2023	ACH 102523	Comcast	12788 Meritage Blvd. OFC 4 Oct 03, 2023 to Nov 02, 2023		359.30	275,513.54
10/27/2023	100337	Buehler Air Conditioning	Invoice: #118622 (Reference: Carrier 5 Ton Heat Pump Condenser.)		6,271.00	269,242.54
10/27/2023	100338	Integrated Access Solutions	Invoice: 0004127 (Reference: Service Call.)		326.00	268,916.54
10/27/2023	100339	Beaches Electrical Service, Inc.	Invoice: 12671 (Reference: Service Call.)		299.95	268,616.59
10/30/2023	1226	Elena Korsakova	BOS Workshop 10/25/23		200.00	268,416.59
10/30/2023	1227	Robert Renn	BOS Workshop 10/25/23		200.00	268,216.59
10/30/2023	1228	Shelia Papelbon	BOS Workshop 10/25/23		200.00	268,016.59
10/30/2023	1030ACH1	Comcast	13077 Beach Blvd. PEDESTRIAN GATE Oct 10, 2023 to Nov 09, 2023		199.35	267,817.24

10/31/2023		Service Charge		2.60	267,814.64
10/31/2023	EOM Balance		69,850.13	153,169.31	267,814.64

HomeGoods

ATLANTIC WEST
11824 ATLANTIC BLVD. #300
JACKSONVILLE, FL 32225
United States
904-646-1989

REGULAR SALE

41 - KITCHEN/ACCESS	148246	\$9.99	T
55 - STATIONERY	857789	\$3.99	T
55 - STATIONERY	841957	\$4.99	T
34 - GLASSWARE	351197	\$9.99	T
34 - GLASSWARE	342116	\$6.99	T
55 - STATIONERY	857796	\$3.99	T
31 - DINNERWARE/CER	810293	\$14.99	T
41 - KITCHEN/ACCESS	128786	\$16.99	T

Subtotal \$71.92
FL 7.50% Sales Tax \$5.39

Total \$77.31

VISA \$77.31

----- TRANSACTION RECORD -----

*****7978

PURCHASE

EXPIRES **/** CONTACTLESS

AUTH# 905215

ATD: A000000031010

APPLICATION LABEL VISA CREDIT

Signature Captured

511/1 41475 08-25-2023 10:51:15

APPROVED

Change \$0.00

HomeGoods VALUES YOUR FEEDBACK!!!

Tell us what you think about
your store visit today and
enter a monthly drawing to win a
\$500 HomeGoods Gift Card!

Visit www.HOMEGOODSFEEDBACK.com

Respond by 9/8/23

You will need to reference
your receipt

Survey number: 0781020190

SEE WEBSITE FOR COMPLETE RULES

Sold Item Count = 8



α T 1131KYEC114111CD4AXJMK α

280781 2 190 08/25/2023 10:49:09 1027

Customer Copy

THANK YOU FOR SHOPPING AT HOMEGOODS

REFUNDS WITHIN 30 DAYS WITH RECEIPT

Store Credit Only With Gift Receipt

Other restrictions may apply



DOLLAR TREE

Store# 3993
 11824-3 Atlantic Blvd
 Jacksonville FL 32225-2918

(904) 380-6169

DESCRIPTION	QTY	PRICE	TOTAL
TABLECOVER BLACK 54X108 PLASTI	1	1.25	1.25T
BAG A BASKET 2PK CLEAR CR	1	1.25	1.25T
BAG A BASKET 2PK CLEAR CR	1	1.25	1.25T

Sub Total \$3.75
 SALES TAX \$0.28
 Total \$4.03
 Visa \$4.03
 *****7978 Approved
 Purchase Cntctless
 Auth/Trace Number: 015201/021422

NOW SHOP ON-LINE AT DOLLARTREE.COM

 * We will gladly exchange any unopened item *
 * with original receipt. We do not offer refunds. *

2416 03993 02 021 27640132 8/25/23 11:10
 Sales Associate: Shawnee

Publix

Kernan Square Shopping Center
12620 Beach Boulevard
Jacksonville, FL 32246
Store Manager: Saneathia McIntyre
904-564-3580

ICE 16 LB	4.49	T F
ICE 16 LB	4.49	T F
CREAM CHS BROWNIES	5.49	F
CREAM CHS BROWNIES	5.49	F
PLAIN BROWNIES 9CT	5.29	F
PLAIN BROWNIES 9CT	5.29	F
ICE 16 LB	4.49	T F
ICE 16 LB	4.49	T F
BH MED NAAN L	39.99	T F
PBX NIBBLER PLTR L	54.99	T F
PBX NIBBLER PLTR L	54.99	T F
BH PROSCIUTTO M	49.99	T F
BH PROSCIUTTO M	49.99	T F
DEVILED EGG PLTR M	29.99	T F
LRG.CAPT.PLATTER	52.99	T F
LRG.CAPT.PLATTER	52.99	T F
LRG.CAPT.PLATTER	52.99	T F
LIMES PERSIAN	4.99	F
ALL AMERICAN PLTR	54.99	T F
LEMONS		
2 @ 0.78	1.56	F
NAVEL ORANGES		
0.74 lb @ 2.19/ lb	1.62	F
SOLO CUP CLEAR		
3 @ 5.49	16.47	T
VISA \$50 GC	50.00	
Account #XXXXXXXXXX7086		
GIFT CARD SVC FEE	5.95	

TAX EXEMPT

Order Total	614.01
Grand Total	614.01
Credit Payment	614.01
Change	0.00

TAX FORGIVEN 39.62

Receipt ID: 0644 8QN 068 105

PRESTO!
Trace #: 060008
Reference #: 0455687340
Acct #: XXXXXXXXXXXX7978
Purchase VISA
Amount: \$614.01
Auth #: 715230

CREDIT CARD	PURCHASE
A000000031010	VISA CREDIT
Entry Method:	Cntctless
Mode:	Issuer

Your cashier was Samuel

08/25/2023 18:03 S0644 R106 8105 C0268

Join the Publix family!
Apply today at apply.publix.jobs.
We're an equal opportunity employer.

Publix

Kernan Square Shopping Center
12620 Beach Boulevard
Jacksonville, FL 32246
Store Manager: Saneathia McIntyre
904-564-3580



0644 8QN 597 662

TAX EXEMPT

TITO'S VODKA		
2 @ 32.63		65.26
MAKERS MARK 750ML		
2 @ 24.99		49.98
Promotion		-10.00
JIM BEAM BOURBON		
2 @ 24.99		49.98
Promotion		-10.00
Order Total		145.22
Grand Total		145.22
Credit	Payment	145.22
Change		0.00

TAX FORGIVEN 10.89

Savings Summary

Special Price Savings 20.00

+ Your Savings at Publix +
+ 20.00 +

Receipt ID: 0644 8QN 597 662

PRESTO!
Trace #: 590540
Reference #: 0455765993
Acct #: XXXXXXXXXXXX/978
Purchase VISA
Amount: \$145.22
Auth #: 715273

CREDIT CARD	PURCHASE
A000000031010	VISA CREDIT
Entry Method:	Contactless
Mode:	Issuer

Cashier Confirmed - Age Over 21

Your cashier was Paul-LQ

08/25/2023 18:37 S0644 R159 7662 C0134

Join the Publix family!
Apply today at apply.publix.jobs.
We're an equal opportunity employer.

Publix Super Markets, Inc.



Final Details for Order #114-4915469-1671430

Order Placed: August 24, 2023
PO number : ron
Amazon.com order number: 114-4915469-1671430
Order Total: \$17.98

Business order information
Location: DSD - Tamaya GL code: 14000 Prepaid Expense Billable / Non-Billable: Non-Billable Cost center: Northeast

Shipped on August 26, 2023	
Items Ordered	Price
2 of: Hayward SP1026 Vinyl/Fiberglass Inlet Fittings for Pools, Spas and Hot Tubs Sold by: Mark's Pool Store (seller profile) Condition: New	\$8.99
Shipping Address: Ron Zastrocky 12788 MERITAGE BLVD JACKSONVILLE, FL 32246-0705 United States	Item(s) Subtotal: \$17.98 Shipping & Handling: \$0.00 ----- Total before tax: \$17.98 Sales Tax: \$0.00 -----
Shipping Speed: FREE Prime Delivery	Total for This Shipment: \$17.98 -----

Payment information	
Payment Method: Visa Last digits: 7978	Item(s) Subtotal: \$17.98 Shipping & Handling: \$0.00 -----
Billing address Ron Zastrocky 12788 MERITAGE BLVD JACKSONVILLE, FL 32246-0705 United States	Total before tax: \$17.98 Estimated Tax: \$0.00 ----- Grand Total: \$17.98
Credit Card transactions	Visa ending in 7978: August 26, 2023: \$17.98

To view the status of your order, return to [Order Summary](#) .

Office DEPOT OfficeMax

JACKSONVILLE - (904) 721-3331

08/25/2023 9:48 AM



VPVT5UXP6R5Y5XBRB

SALE	6491-2-3880-603142-23.6.1
348037 PAPER, COPY, OD,	88.69SS
Instant Savings	-34.70
You Pay	53.99SS
322846 LBL, RMV, 3.5X4.	25.09 SS
Subtotal:	79.08
Fl. 7.0% Sales Tax	5.94
Total:	85.02
Visa 7978:	85.02

AUTH CODE 805294

TDS Contactless

AID A0000000031010 VISA CREDIT

TVR 0000000000

CVS No Signature Required

Total Savings:

\$34.70

XX

WE WANT TO HEAR FROM YOU!

Visit survey.officedepot.com

and enter the survey code below

16KB 1F37 7G86

or scan the below QR code





How doers
get more done.

12721 ATLANTIC BLVD
JACKSONVILLE, FL 32225 (904)2200822

6365 00009 88675 08/26/23 03:41 PM
SALE CASHIER EMARI

044600311227 CLEANUP GAL <A>
CLX APC BLEACH REFILL 128OZ
2@16.28 32.56N
827854010340 FABLAV169OZ <A>
FABULOSO 2X APC LAVENDER 169OZ
2@9.98 19.96

SUBTOTAL 52.52
SALES TAX 1.50
TOTAL \$54.02

XXXXXXXXXXXX7978 VISA USD\$ 54.02
AUTH CODE 416224/4091464 TA
Chip Read
AID A0000000031010 VISA CREDIT

PRO XTRA MEMBER STATEMENT

PRO XTRA ###-###-2277 SUMMARY
THIS RECEIPT PO/JOB NAME: 0

2023 PRO XTRA SPEND 08/25: \$1,469.89
INCLUDES:
2023 PROXTRA SAVINGS 08/25: \$10.09

As of 08/26/2023 your Paint Rewards
level is Member; Spend 993.02 more in
qualifying paint purchases to earn
Bronze (10.0% off) on select paint
items.

Get the CREDIT LINE your business needs
PLUS earn Perks 4X FASTER when you join
Pro Xtra, register, & use your Pro Xtra
Credit Card. Apply and SAVE UP TO \$100.
Learn more at homedepot.com/credit

6365 08/26/23 03:41 PM



6365 09 88675 08/26/2023 8925

RETURN POLICY DEFINITIONS
POLICY ID DAYS POLICY EXPIRES ON
A 1 90 11/24/2023

DID WE NAIL IT?

Take a short survey for a chance TO WIN



Credit Services - Receipt LookUp Receipt

Printed on: 08/26/2023 1

Transaction Identifier : [6365, 08/26/2023, 62, 4288]

Receipt Image



How doers get more done.

12721 ATLANTIC BLVD
JACKSONVILLE, FL 32225 (904)2200822

6365 00062 42887 08/26/23 03:27 PM
SALE SELF CHECKOUT

736511500622 62SARGENTKEY <A>	
62 SARGENT	
3@3.97	11.91
736511500684 68SCHLAGEKEY <A>	
68 KEY SCHLAGE	
3@3.97	11.91
	SUBTOTAL 23.82
	SALES TAX 1.79
	TOTAL \$25.61

XXXXXXXXXXXX7978 VISA USD\$ 25.61
 AUTH CODE 416292/4622577 TA
 Chip Read
 AID A0000000031010 VISA CREDIT

PRO XTRA MEMBER STATEMENT

PRO XTRA ###-###-2277 SUMMARY
THIS RECEIPT PO/JOB NAME: 0000

2023 PRO XTRA SPEND 08/25:	\$1,446.07
INCLUDES:	
2023 PROXTRA SAVINGS 08/25:	\$10.09

As of 08/26/2023 your Paint Rewards level is Member; Spend 993.02 more in qualifying paint purchases to earn Bronze (10.0% off) on select paint items.

Get the CREDIT LINE your business needs PLUS earn Perks 4X FASTER when you join Pro Xtra, register, & use your Pro Xtra Credit Card. Apply and SAVE UP TO \$100. Learn more at homedepot.com/credit

6365 08/26/23 03:27 PM

Account Details

Xref number	Account Number	Type	ExpDate	Signature
XXXXXXXXXXXX7978	XXXXXXXXXXXX7978	VI	06/27	Y
EMV Brand	Application ID A0000000031010	EMV brand application name :		VISA CREDI
CVM code :	7	CVM description :		SIGNA
Display CVM code :	SIGNATURE	EMV fallback indicator :		NA

Miscellaneous Details

Sales Posting Date : 08/26/2023

Publix

Kernan Square Shopping Center
12620 Beach Boulevard
Jacksonville, FL 32246
Store Manager: Saneathia McIntyre
904-564-3580



0644 8WN 036 603

PUBLIX SPRNG 24PK
4 @ 2 FOR 8.00 16.00 F
You Saved 2.36

Order Total 16.00
Sales Tax 0.00
Grand Total 16.00
Credit Payment 16.00
Change 0.00

Savings Summary
Special Price Savings 2.36

* Your Savings at Publix *
* 2.36 *

Receipt ID: 0644 8WN 036 603

PRESTO!
Trace #: 035438
Reference #: 0602057379
Acct #: XXXXXXXXXXXX7978
Purchase VISA
Amount: \$16.00
Auth #: 011323

CREDIT CARD PURCHASE
A0000000031010 VISA CREDIT
Entry Method: Cntless
Mode: Issuer

Your cashier was Bennett

08/31/2023 11:32 S0644 R103 6603 C0204

The UPS Store #3547
12620 BEACH BLVD STE 3
JACKSONVILLE, FL 32246-7130
904-642-1070

Terminal....: POS3547A Date.: 9/5/2023
Employee....: 262049 Time.: 03:27 PM

ITEM NAME	QTY	PRICE	TOTAL
Ground Commercial			\$11.98
	1 @	\$11.98	
Tax			\$0.00
MNYBR3HNPGB3			
Tracking Number - 1ZAG01730349571947			
Photo Fiberboard- 5.75x8.25			\$1.99
	1 @	\$1.99	
Tax			\$0.15
Book of Stamps 20			\$13.50
	1 @	\$13.50	
Tax			\$0.00
Subtotal			\$27.47
Shipping/Other Charges			\$0.00
Total tax			\$0.15
Total			\$27.62
Cards			\$27.62

Items Designated NR are NOT eligible
for Returns, Refunds or Exchanges.

US Postal Rates Are Subject to Surcharge.



View the UPS Store, Inc.'s privacy notice at
<https://www.theupsstore.com/privacy-policy>

Win a \$250 gift card

Tell us how we're doing for your chance to win
a \$250 gift card. Scan the QR code or visit
the URL below to...

ol
Publix

Kernan Square Shopping Center
 12620 Beach Boulevard
 Jacksonville, FL 32246
 Store Manager: Saneathia McIntyre
 904-564-3580



0644 98N 070 791

RITZ PARTY SIZE	7.29	F
PUB RICH N CRISP	3.99	F
CHINET PLATE DINNR	18.99	T
PUB CUP COLOR 18OZ	6.99	T
PUB CUP COLOR 18OZ	6.99	T
SOLO CUP CLEAR	5.49	T
SOLO CUP CLEAR	5.49	T
SOLO CUP CLEAR	5.49	T
SOLO CUP CLEAR	5.49	T
SOLO CUP CLEAR	5.49	T
SOLO CUP CLEAR	5.49	T
SOLO CUP CLEAR	5.49	T
SOLO CUP CLEAR	5.49	T
SOLO CUP CLEAR	5.49	T
SOLO CUP CLEAR	5.49	T
SOLO CUP CLEAR	5.49	T
SOLO CUP CLEAR	5.49	T
VANITY FAIR BEV NK	2.99	
VANITY FAIR BEV NK	2.99	
VANITY FAIR BEV NK	2.99	
VANITY FAIR BEV NK	2.99	
VANITY FAIR BEV NK	2.99	
VANITY FAIR BEV NK	2.99	
PUB DNNRWARE COMBO	12.99	T
PUB DNNRWARE COMBO	12.99	T
PUB DRINKING WATER	1.09	F
PUB DRINKING WATER	1.09	F
DELI LEMONADE GAL		
1 @ 2 FOR 7.00	3.50	T F

ol
Publix

Kernan Square Shopping Center
 12620 Beach Boulevard
 Jacksonville, FL 32246
 Store Manager: Saneathia McIntyre
 904-564-3580



0644 98N 599 970

 RECALL TRANSACTION
 TERMINAL: 159
 TRANS-NO: 9964

MAKERS MARK 750ML		
2 @ 24.99	49.98	T
Promotion	-10.00	T
CHESTERFIELD BEER		
2 @ 16.29	32.58	T
ICE 16 LB		
4 @ 4.49	17.96	T F
PUBLIX CLUB SODA		
3 @ 0.85	2.55	T F
TAX EXEMPT		

Order Total	93.07
Grand Total	93.07
Credit Payment	93.07
Change	0.00
TAX FORGIVEN	6.98

Savings Summary
 Special Price Savings 10.00

 * Your Savings at Publix *
 * 10.00 *

ol.

Publix

Kernan Square Shopping Center
12620 Beach Boulevard
Jacksonville, FL 32246
Store Manager: Saneathia McIntyre
904-564-3580



0644 98N 070 791

RITZ PARTY SIZE	7.29	F
PUB RICH N CRISP	3.99	F
CHINET PLATE DINNR	18.99	T
PUB CUP COLOR 18OZ	6.99	T
PUB CUP COLOR 18OZ	6.99	T
SOLO CUP CLEAR	5.49	T
SOLO CUP CLEAR	5.49	T
SOLO CUP CLEAR	5.49	T
SOLO CUP CLEAR	5.49	T
SOLO CUP CLEAR	5.49	T
SOLO CUP CLEAR	5.49	T
SOLO CUP CLEAR	5.49	T
SOLO CUP CLEAR	5.49	T
SOLO CUP CLEAR	5.49	T
SOLO CUP CLEAR	5.49	T
SOLO CUP CLEAR	5.49	T
SOLO CUP CLEAR	5.49	T
SOLO CUP CLEAR	5.49	T
VANITY FAIR BEV NK	2.99	
VANITY FAIR BEV NK	2.99	
VANITY FAIR BEV NK	2.99	
VANITY FAIR BEV NK	2.99	
VANITY FAIR BEV NK	2.99	
VANITY FAIR BEV NK	2.99	
PUB DNNRWARE COMBO	12.99	T
PUB DNNRWARE COMBO	12.99	T
PUB DRINKING WATER	1.09	F
PUB DRINKING WATER	1.09	F
DELI LEMONADE GAL		
1 @ 2 FOR 7.00	3.50	T F
TABLE COVER 60X108	4.49	T
DIET COCA-COLA	8.79	T F
TOSTITOS CANT TRAD	5.99	F
TOSTITOS CANT TRAD	5.99	F
BH ITALIAN VIRTUOSO	149.98	T F
ALL AMERICAN PLTR	109.98	T F
TAX EXEMPT		

Order Total	450.44	
Grand Total	450.44	
Credit	Payment	450.44
Change	0.00	

TAX FORGIVEN 30.53



Final Details for Order #114-7092016-1220251

Order Placed: September 7, 2023
PO number : ron
Amazon.com order number: 114-7092016-1220251
Order Total: \$39.99

Business order information
Location: DSD - Beach (Tamaya) GL code: 14000 Prepaid Expense Billable / Non-Billable: Non-Billable Cost center: Northeast

Shipped on September 8, 2023	
Items Ordered	Price
1 of: <i>EVERSPROUT 5-to-12 Foot Cobweb Duster with Extension Pole Combo (20 Ft Reach, Medium-Stiff Bristles), Spider Web Brush with Pole - Hand-Packaged, Ligh</i> Sold by: Eversprout (seller profile) Condition: New	\$39.99
Shipping Address: Ron Zastrocky 12788 MERITAGE BLVD JACKSONVILLE, FL 32246-0705 United States	Item(s) Subtotal: \$39.99 Shipping & Handling: \$0.00 ----- Total before tax: \$39.99 Sales Tax: \$0.00 -----
Shipping Speed: FREE Prime Delivery	Total for This Shipment: \$39.99 -----

Payment information	
Payment Method: Visa Last digits: 7978	Item(s) Subtotal: \$39.99 Shipping & Handling: \$0.00 -----
Billing address Ron Zastrocky 12788 MERITAGE BLVD JACKSONVILLE, FL 32246-0705 United States	Total before tax: \$39.99 Estimated Tax: \$0.00 ----- Grand Total: \$39.99
Credit Card transactions	Visa ending in 7978: September 8, 2023: \$39.99

To view the status of your order, return to [Order Summary](#) .

The UPS Store #3547
12620 BEACH BLVD STE 3
JACKSONVILLE, FL 32246-7130
904-642-1070

Terminal.....: POS3547A Date.: 9/15/2023
Employee.....: 265491 Time.: 10:07 AM

ITEM NAME	QTY	PRICE	TOTAL
Ground Residential			\$14.50
Tax	1 @	\$14.50	\$14.50
MYBR3HJVH8G4			\$0.00
Tracking Number - 1ZAG01730316848175			
Subtotal			\$14.50
Shipping/Other Charges			\$0.00
Total tax			\$0.00
Total			\$14.50
Cards			\$14.50

Items Designated NR are NOT eligible
for Returns, Refunds or Exchanges.

US Postal Rates Are Subject to Surcharge.



1 2 3 0 9 1 5 3 5 4 7 A 0 2 6 1 5 7

View The UPS Store, Inc.'s privacy notice at
<https://www.theupsstore.com/privacy-policy>

Win a \$250 gift card
Tell us how we're doing for your chance to win
a \$250 gift card. Scan the QR code or visit
the URL below to take the survey.



0644 99N 590 183

ICE 16 LB		4.49	T F
CHESTERFIELD BEER		16.29	T
TITO'S VODKA		32.63	T
TITO'S VODKA		32.63	T
LIMES PERSIAN			
4 @	0.69	2.76	F
TAX EXEMPT			
Order Total		88.80	
Grand Total		88.80	
Credit	Payment	88.80	
Change		0.00	
TAX FORGIVEN		6.45	

Receipt ID: 0644 99N 590 183

PRESTO!
Trace #: 592597
Reference #: 0611830733
Acct #: XXXXXXXXXXXXX7978
Purchase VISA
Amount: \$88.80
Auth #: 519004

CREDIT CARD	PURCHASE
A0000000031010	VISA CREDIT
Entry Method:	Chip Read
Mode:	Issuer

Cashier Confirmed - Age Over 21

Your cashier was Bren-Liq

09/09/2023 16:40 S0644 R159 0183 C0140

Join the Publix family!
Apply today at apply.publix.jobs.
We're an equal opportunity employer.

Publix Super Markets, Inc.

904-584-5500



0644 99N 590 183

ICE 16 LB	4.49	T F
CHESTERFIELD BEER	16.29	T
TITO'S VODKA	32.63	T
TITO'S VODKA	32.63	T
LIMES PERSIAN		
4 @ 0.69		
TAX EXEMPT	2.76	F
Order Total	88.80	
Grand Total	88.80	
Credit	88.80	
Change	0.00	
TAX FORGIVEN	6.45	

Receipt ID: 0644 99N 590 183

PRESTO!
 Trace #: 592597
 Reference #: 0611830733
 Acct #: XXXXXXXXXXXX7978
 Purchase VISA
 Amount: \$88.80
 Auth #: 519004

CREDIT CARD
 A0000000031010
 Entry Method:
 Mode:

PURCHASE
 VISA CREDIT
 Chip Read
 Issuer

Cashier Confirmed - Age Over 21
 Your cashier was Bren-Liq

9/09/2023 16:40 S0644 R159 0183 C0140

Join the Publix family!
 Apply today at apply.publix.jobs
 We're an equal opportunity
 Publix Super



0644 9GN 016 985

SPRITE 12 PK 12 OZ	8.79	T F
ICE 16 LB		
2 @ 4.49	8.98	T F
COCA-COLA CLASSIC	8.79	T F
DIET COCA-COLA	8.79	T F
BOUNTY NAPKNS_PRNT	4.59	T
PUB ED PLSTC COMBO	9.99	T
TOSTITOS CANT TRAD	5.99	F
TOSTITOS CANT TRAD	5.99	F
HEFTY FOAM PLATES	7.99	T
PUBLIX SPRNG 24PK		
2 @ 4.49	8.98	F
DESERT CON QUESO	4.79	F
ON BORDER SALS MED	4.05	F
TAX EXEMPT		

Order Total	87.72
Grand Total	87.72
Credit	87.72
Change	0.00
Payment	4.34

TAX FORGIVEN

Receipt ID: 0644 9GN 016 985

PRESTO!
 Trace #: 012267
 Reference #: 0471730639
 Acct #: XXXXXXXXXXXX7978

12200 ATLANTIC BLVD.
JACKSONVILLE, FL
Club Mgr. Jeffrey Wellesley

Club:108 Reg:52 Trans:1033
Cashier:602 09/16/23 11:28am

*** MEMBERSHIP ID. 10844629145 ***
*** MEMBERSHIP EXPIRES ON 05/24 ***

71752472793 VEGG PLATTER 13.98 N
2 @ 6.99
*** SUBTOTAL 13.98
*** TOTAL 13.98

*****7978 ENTRY: H
Purchase 00 APPROVED
AUTH 016182
TERMINAL NUMBER 78073010852
09/16/23 11:28am 108 52 1033 602
VISA CREDIT
AID: A0000000031010

Visa 13.98
CHANGE 0.00

TOTAL ITEMS= 2

As a BJ's Member I JUST SAVED: \$2.80

BJ's Member Savings 2.80
Coupons Redeemed 0.00
Rewards Redeemed 0.00

Current BJ's Gas Savings

FuelSaver earned thru 09/15/23 0.00/gal
FuelSaver earned in this trx: 0.00/gal
Visit BJs.com/Gas for more details

ENTER FOR A CHANCE TO
WIN A BJ's GIFT CARD!



Scan the QR code above or visit
BJs.com/feedback for survey & rules

MEMBER COPY



0916108521033

*** Check Card ***

12200 ATLANTIC BLVD.
JACKSONVILLE, FL
Club Mgr. Jeffrey Wellesley

Club:103 Reg:56 Trans:2035
Cashier:606 09/21/23 01:59 PM

*** MEMBERSHIP ID. 10844629145 ***
*** MEMBERSHIP EXPIRES ON 05/24 ***

4750000372 BR SAUSAGE 35.94 N
6 @ 5.99
4400000362 40Z WHF THIN 8.99 N
4400005297 TRIP CUP 8.99 N
20444500000 3 YEAR C DR 9.99 N
88867010622 WFL CHEESE 7.99 N
88867010620 WFL CHEESE 7.99 N
19572 PIZZA BACK 8.98 N
2840007469 FRI SAUSA 9.49 N
64767143009 GF FISH SAUSA 13.98 N
2 @ 6.99
*** SUBTOTAL 112.34
*** TOTAL 112.34

*****7978 ENTRY: H
Purchase 00 APPROVED
AUTH 311210
TERMINAL NUMBER 78073010852
09/21/23 01:59 PM 103 56 2035 606
VISA CREDIT
AID: A0000000031010

Visa 112.34
CHANGE 0.00

TOTAL ITEMS= 15

As a BJ's Member I JUST SAVED: \$22.47

BJ's Member Savings 22.47
Coupons Redeemed 0.00
Rewards Redeemed 0.00

Current BJ's Gas Savings

FuelSaver earned thru 09/20/23 0.00/gal
FuelSaver earned in this trx: 0.00/gal
Visit BJs.com/Gas for more details

MEMBER COPY



0921108521035



0644 9GN 016 985

SPRITE 12 PK 12 OZ	8.79	T F
ICE 16 LB	8.98	T F
2 @ 4.49	8.79	T F
COCA-COLA CLASSIC	8.79	T F
DIET COCA-COLA	4.59	T
BOUNTY NAPKNS_PRNT	9.99	T
PUB ED PLSTC COMBO	5.99	F
TOSTITOS CANT TRAD	5.99	F
TOSTITOS CANT TRAD	7.99	T
HEFTY FOAM PLATES		
PUBLIX SPRNG 24PK	8.98	F
2 @ 4.49	4.79	F
DESERT CON QUESO	4.05	F
ON BORDER SALS MED		
TAX EXEMPT		
Order Total	87.72	
Grand Total	87.72	
Credit Payment	87.72	
Change	0.00	
TAX FORGIVEN	4.34	

Receipt ID: 0644 9GN 016 985

PRESTO!
 Trace #: 012267
 Reference #: 0471730639
 Acct #: XXXXXXXXXXXXXXX7079

Karaoke Night



Store# 5104
 8011 Merrill Rd Ste 2
 Jacksonville FL 32277-6545

(904) 924-6002

DESCRIPTION	QTY	PRICE	TOTAL
HEFTY STORAGE ZIP GA 5CT	1	1.25	1.25T
HEFTY STORAGE ZIP GA 5CT	1	1.25	1.25T
TOOTHPICK ASTO CLIP PBH CS	1	1.25	1.25T
MC RECT STORAGE 12 CUP	1	1.25	1.25T
MC RECT STORAGE 12 CUP	1	1.25	1.25T
TABLECOVER ROYAL BLUE 54X108 P	1	1.25	1.25T
TABLECOVER ROYAL BLUE 54X108 P	1	1.25	1.25T
TABLECOVER ROYAL BLUE 54X108 P	1	1.25	1.25T
Sub Total			\$10.00
SALES TAX			\$0.75
Total			\$10.75
VISA CREDIT			\$10.75
*****7978			Approved
Purchase			Chip
Auth/Trace Number:			711254/030131
Chip Card AID:			A0000000031010

NOW SHOP ON-LINE AT DOLLARTREE.COM

 * We will gladly exchange any unopened item *
 * with original receipt. We do not offer refunds. *

 2643 05104 03 020 27667546 9/21/23 18:44
 Sales Associate:Samantha



Final Details for Order #114-9595297-8854625

Order Placed: September 21, 2023
PO number : ron
Amazon.com order number: 114-9595297-8854625
Order Total: \$29.84

Business order information
Location: DSD - Beach (Tamaya)
GL code: 14000 Prepaid Expense
Billable / Non-Billable: Non-Billable
Cost center: Northeast

Shipped on September 21, 2023
Items Ordered Price
1 of: Reliable RFC White Cover Plate Assembly 135 Degree \$12.15
Sold by: SOUTH AVE EAST LLC (seller profile) | Product question? (Ask Seller.)
Business Price
Condition: New
Shipping Address: Item(s) Subtotal: \$12.15
Ron Zastrocky Shipping & Handling: \$0.00
12788 MERITAGE BLVD
JACKSONVILLE, FL 32246-0705
United States Total before tax: \$12.15
Sales Tax: \$0.00
Shipping Speed:
FREE Prime Delivery Total for This Shipment: \$12.15

Shipped on September 21, 2023
Items Ordered Price
1 of: 3-5/16Inch Inch The Inchinch White Concealed Cover Plate (135 Degree F) \$17.69
Sold by: Amazon Warehouse (seller profile)
Condition: Used - Like New Looks and functions as if it were new. Packaging shows minimal signs of wear, consistent with being opened.
Shipping Address: Item(s) Subtotal: \$17.69
Ron Zastrocky Shipping & Handling: \$0.00
12788 MERITAGE BLVD
JACKSONVILLE, FL 32246-0705
United States Total before tax: \$17.69
Sales Tax: \$0.00
Shipping Speed:
FREE Prime Delivery Total for This Shipment: \$17.69

Payment information

Payment Method:
Visa | Last digits: 7978

Item(s) Subtotal: \$29.84
Shipping & Handling: \$0.00

Billing address
Ron Zastrocky
12788 MERITAGE BLVD
JACKSONVILLE, FL 32246-0705
United States

Total before tax: \$29.84
Estimated Tax: \$0.00

Grand Total: \$29.84

Credit Card transactions

Visa ending in 7978: September 21, 2023: \$29.84

To view the status of your order, return to [Order Summary](#) .

[Conditions of Use](#) | [Privacy Notice](#) © 1996-2020, Amazon.com, Inc.

Buchanan Sign & Flag

6755 Beach Blvd.
Jacksonville, FL 32216
(904) 725-5500

ticket #R-28420-01
Station:POS2
9/21/2023 11:10:58 AM

User: KGC
Sales Rep JC

Item Description	Qty	Price	Total
------------------	-----	-------	-------

SIGNSPC 20X20IN OBO ALUM BLACK ON WHITE POLICY SI GN	1	82.50	82.50
--	---	-------	-------

NOTE DISTRICT POLICY REQUIRES PHOTO ID AND KEY SCAN	1	0.00	0.00
---	---	------	------

NOTE CARD TO GAIN ENTRY TO AMENITIES	1	0.00	0.00
---	---	------	------

NOTE PLEASE BE PREPARED TO SHOW YOUR ID AND CA RD	1	0.00	0.00
---	---	------	------

WO WORK ORDER #96006	1	0.00	0.00
-------------------------	---	------	------

STATUS 09/19/23 HMO LEFT MESSAGE FOR RON	1	0.00	0.00
---	---	------	------

Subtotal 82.50

Total 82.50

Tender:
VISA 82.50
XXXXXXXXXXXX7978

Batch: 230921001
Auth: 011201
Entry Method: EMV Contact
VISA CREDIT
AID: A000000031010
TVR: 6080008000
TSI: 6800
AC: 5098981C40538FB0
CVN: sig
Authorization Mode: ISSUER

Order # R-28420
Order Total 0.00
Order amt due 0.00

Number of items purchased:6

BEACH COMMUNITY DEVELOPEME
3501 QUADRANGLE BLVD
SUITE 270
ORLANDO, FL 32817-1450
577-3075-RON ZASTROCKY

Customer PO TAMAYA

Thank you for your business!



1200 ATLANTIC BLVD.
JACKSONVILLE, FL
Club Mgr. Jeffrey Wellerley

Club: 108 Reg: 57 Phone: 1890
Cashier: 607 09/22/23 04:16pm

*** MEMBERSHIP ID: 1004462145 ***

*** MEMBERSHIP EXPIRES ON: 05/24 ***

7343000014	ZEPHYR WATER	9.99 N
8615200011	ICE 20oz	4.49 T
5410000270	WHOLE EGG BY	4.99 N

**** SUBTOTAL 19.47

FL 7.5% Tax: 0.34

**** TOTAL 19.81

***** 7978 ENTRY: 1

Purchase OK APPROVED

AUTH 512261

TERMINAL NUMBER 7873010857

09/22/23 04:16pm 108 57 1890 607

VISA CREDIT

AID: A00000003101

Visa 19.81

CHANGE 0.00

TOTAL ITEMS = 3

As a BJ's Member **JUST SAVED: \$3.89**

BJ's Member Savings 3.89

Coupons Redeemed 0.00

Rewards Redeemed 0.00

Current BJ's Club Savings

FuelSaver earned thru 09/22/23 0.00/gal

FuelSaver earned on this trip: 0.00/gal

Visit BJs.com/Clubs for more details

MEMBER COPY



0922185896



BNY MELLON

The Bank of New York Mellon Trust Company, N.A.

Account Statement

Statement Period 10/01/2023 Through 10/31/2023

Account 171066 Base Currency = USD
BEACH CDD 2013A ACQ CONST SUBACCT

CLIENT SERVICE MANAGER: CAROLINE COWART
4655 SALISBURY RD STE 300
AIM-324-0000
JACKSONVILLE, FL 32256
904-645-1919
CAROLINE.COWART@BNYMELLON.COM

Go Paperless.

Securely access your accounts online to view your statements. Ask your BNY Mellon contact how we can help you access your account balances and activity in real time, receive your reports, enter your own transactions or submit an audit confirmation online. Also be sure to ask how NEXEN(SM) Gateway, our new cloud-based ecosystem, can help you.

Visit us at www.bnymellon.com

Summary of Assets Held by Asset Classification

Asset Classification	Market Value	Cost	Accrued Income	Estimated Annual Income	Market Yield
No Assets Held					

Summary of Cash Transactions by Transaction Category

Transaction Category	Current Period			Year-to-Date	
	Income	Principal	Realized Gains/Losses	Income	Principal
OPENING BALANCE	0.00	0.00		0.00	0.00
CLOSING BALANCE	0.00	0.00	0.00	0.00	0.00

The above cash transactions summary is provided for information purposes only and may not reflect actual taxable income or deductible expenses as reportable under the Internal Revenue Code.

Statement of Transactions by Transaction Date

Transaction Date	Transaction Description	Income	Principal	Cost	Realized Gains/Losses
No Transactions This Period					

Cumulative realized capital gain and loss position from 12/31/2022 for securities held in principal of account:

Short Term: 0.00 * Long Term: 0.00 *

* The above gain and loss position does not include transactions where tax cost information is incomplete or unavailable.

a 026934 n 012883 a 02 1 DOM 1 W1 S 50757



BNY MELLON

The Bank of New York Mellon Trust Company, N.A.

Statement Period 10/01/2023 Through 10/31/2023

Account 171066

Base Currency = USD

BEACH CDD 2013A ACQ CONST SUBACCT

Cash and securities set forth on this Account Statement are held by The Bank of New York Mellon, an affiliate of The Bank of New York Mellon Trust Company, N.A. In addition, The Bank of New York Mellon Trust Company, N.A. may utilize subsidiaries and affiliates to provide services and certain products to the Account. Subsidiaries and affiliates may be compensated for their services and products.

The value of securities set forth on this Account Statement are obtained by The Bank of New York Mellon Trust Company, N.A., from its affiliate, The Bank of New York Mellon which determines such values for Corporate Trust on the basis of market prices and information obtained by The Bank of New York Mellon from unaffiliated third parties (including independent pricing vendors) ("third party pricing services"). The Bank of New York Mellon has not verified such market values or information and makes no assurances as to the accuracy or correctness of such market values or information or that the market values set forth on this Account Statement reflect the value of the securities that can be realized upon the sale of such securities. In addition, the market values for the securities set forth in this Account Statement may differ from the market prices and information for the same securities used by other business units of The Bank of New York Mellon Trust Company, N.A., The Bank of New York Mellon or their respective subsidiaries or affiliates based upon market prices and information received from other third party pricing services utilized by such other business units. Corporate Trust does not compare its market values with those used by, or reconcile different market values used by, other business units of The Bank of New York Mellon Trust Company, N.A., The Bank of New York Mellon or their respective subsidiaries or affiliates. Neither The Bank of New York Mellon Trust Company, N.A. nor The Bank of New York Mellon shall be liable for any loss, damage or expense incurred as a result of or arising from or related to the market values or information provided by third party pricing services or the differences in market prices or information provided by other third party pricing services.

e 026934 n 012883 a 02 t DOM i WI s 50758



BNY MELLON

The Bank of New York Mellon Trust Company, N.A.

Account Statement

Statement Period 10/01/2023 Through 10/31/2023

Account 171068 Base Currency = USD
BEACH CDD 2013A SINKING FUND ACCT

CLIENT SERVICE MANAGER: CAROLINE COWART
4655 SALISBURY RD STE 300
AIM-324-0000
JACKSONVILLE, FL 32256
904-645-1919
CAROLINE.COWART@BNYMELLON.COM

Go Paperless.

Securely access your accounts online to view your statements. Ask your BNY Mellon contact how we can help you access your account balances and activity in real time, receive your reports, enter your own transactions or submit an audit confirmation online. Also be sure to ask how NEXEN(SM) Gateway, our new cloud-based ecosystem, can help you.

Visit us at www.bnymellon.com

Summary of Assets Held by Asset Classification

Asset Classification	Market Value	Cost	Accrued Income	Estimated Annual Income	Market Yield
No Assets Held					

Summary of Cash Transactions by Transaction Category

Transaction Category	Current Period			Year-to-Date	
	Income	Principal	Realized Gains/Losses	Income	Principal
OPENING BALANCE	0.00	0.00		0.00	0.00
OTHER CASH ADDITIONS	0.00	0.00	0.00	0.00	175,000.00
OTHER CASH DISBURSEMENTS	0.00	0.00	0.00	0.00	175,000.00 -
CLOSING BALANCE	0.00	0.00	0.00	0.00	0.00

The above cash transactions summary is provided for information purposes only and may not reflect actual taxable income or deductible expenses as reportable under the Internal Revenue Code.

Statement of Transactions by Transaction Date

Transaction Date	Transaction Description	Income	Principal	Cost	Realized Gains/Losses
No Transactions This Period					

Cumulative realized capital gain and loss position from 12/31/2022 for securities held in principal of account:

Short Term: 0.00 * Long Term: 0.00 *

* The above gain and loss position does not include transactions where tax cost information is incomplete or unavailable.



BNY MELLON

The Bank of New York Mellon Trust Company, N.A.

Statement Period 10/01/2023 Through 10/31/2023

Account 171068 Base Currency = USD

BEACH CDD 2013A SINKING FUND ACCT

Cash and securities set forth on this Account Statement are held by The Bank of New York Mellon, an affiliate of The Bank of New York Mellon Trust Company, N.A. In addition, The Bank of New York Mellon Trust Company, N.A. may utilize subsidiaries and affiliates to provide services and certain products to the Account. Subsidiaries and affiliates may be compensated for their services and products.

The value of securities set forth on this Account Statement are obtained by The Bank of New York Mellon Trust Company, N.A., from its affiliate, The Bank of New York Mellon which determines such values for Corporate Trust on the basis of market prices and information obtained by The Bank of New York Mellon from unaffiliated third parties (including independent pricing vendors) ("third party pricing services"). The Bank of New York Mellon has not verified such market values or information and makes no assurances as to the accuracy or correctness of such market values or information or that the market values set forth on this Account Statement reflect the value of the securities that can be realized upon the sale of such securities. In addition, the market values for the securities set forth in this Account Statement may differ from the market prices and information for the same securities used by other business units of The Bank of New York Mellon Trust Company, N.A., The Bank of New York Mellon or their respective subsidiaries or affiliates based upon market prices and information received from other third party pricing services utilized by such other business units. Corporate Trust does not compare its market values with those used by, or reconcile different market values used by, other business units of The Bank of New York Mellon Trust Company, N.A., The Bank of New York Mellon or their respective subsidiaries or affiliates. Neither The Bank of New York Mellon Trust Company, N.A. nor The Bank of New York Mellon shall be liable for any loss, damage or expense incurred as a result of or arising from or related to the market values or information provided by third party pricing services or the differences in market prices or information provided by other third party pricing services.

e 026935 n 012884 a 02 t DOM i WI s 50760



BNY MELLON

The Bank of New York Mellon Trust Company, N.A.

Account Statement

Statement Period 10/01/2023 Through 10/31/2023

Account 171078 Base Currency = USD
BEACH CDD 2013A INTEREST ACCT

CLIENT SERVICE MANAGER: CAROLINE COWART
4655 SALISBURY RD STE 300
AIM-324-0000
JACKSONVILLE, FL 32256
904-645-1919
CAROLINE.COWART@BNYMELLON.COM

Go Paperless.

Securely access your accounts online to view your statements. Ask your BNY Mellon contact how we can help you access your account balances and activity in real time, receive your reports, enter your own transactions or submit an audit confirmation online. Also be sure to ask how NEXEN(SM) Gateway, our new cloud-based ecosystem, can help you.

Visit us at www.bnymellon.com

Account Overview

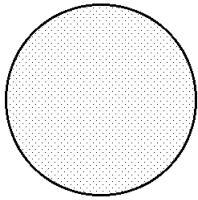

Percent of all Investments	Asset Classification	Market Value
100%	CASH AND SHORT TERM	305,035.00
100%	TOTAL OF ALL INVESTMENTS	305,035.00

Summary of Assets Held by Asset Classification

Asset Classification	Market Value	Cost	Accrued Income	Estimated Annual Income	Market Yield
CASH AND SHORT TERM	305,035.00	305,035.00	0.00	0.00	0.00 %
ACCOUNT TOTALS	305,035.00	305,035.00	0.00	0.00	0.00 %

Summary of Cash Transactions by Transaction Category

Transaction Category	Current Period			Year-to-Date	
	Income	Principal	Realized Gains/Losses	Income	Principal
OPENING BALANCE	0.00	0.00		0.00	0.00
OTHER CASH ADDITIONS	0.00	305,035.00	0.00	0.00	616,460.00
OTHER CASH DISBURSEMENTS	0.00	0.00	0.00	0.00	311,425.00-



BNY MELLON

The Bank of New York Mellon Trust Company, N.A.

Statement Period 10/01/2023 Through 10/31/2023

Account 171078 Base Currency = USD

BEACH CDD 2013A INTEREST ACCT

Summary of Cash Transactions by Transaction Category - Continued

Transaction Category	Current Period			Year-to-Date	
	Income	Principal	Realized Gains/Losses	Income	Principal
CLOSING BALANCE	0.00	305,035.00	0.00	0.00	305,035.00

The above cash transactions summary is provided for information purposes only and may not reflect actual taxable income or deductible expenses as reportable under the Internal Revenue Code.

e 026936 n 012885 a 02 t DOM i W1 s 50762



BNY MELLON

The Bank of New York Mellon Trust Company, N.A.

Statement Period 10/01/2023 Through 10/31/2023

Account 171078 Base Currency = USD

BEACH CDD 2013A INTEREST ACCT

Statement of Assets Held by Asset Classification

Shares/Par Value	Asset Description	Market Price	Market Value	Cost	Average Cost	Accrued Income	Estimated Income	Market Yield
CASH AND SHORT TERM								
	CASH BALANCE		305,035.00	305,035.00	0.00000	0.00	0.00	0.00%
Total CASH AND SHORT TERM			305,035.00	305,035.00		0.00	0.00	0.00%
ACCOUNT TOTALS			305,035.00	305,035.00		0.00	0.00	0.00%

Total Market Value Plus Total Accrued Income 305,035.00

Statement of Transactions by Transaction Date

Transaction Date	Transaction Description	Income	Principal	Cost	Realized Gains/Losses
10/01/23	ACCOUNT OPENING PERIOD BALANCE	0.00	0.00	0.00	
10/31/23	Cash Credit DR PARTY: BEACH CDD 2013A REVENUE ACCT DETAIL: /BNF/INTEREST DUE 11/1/2023 REL REF: CWP-2142807	0.00	305,035.00	0.00	0.00
10/31/23	ACCOUNT CLOSING DAILY BALANCE	0.00	305,035.00	0.00	0.00
10/31/23	ACCOUNT CLOSING PERIOD BALANCE	0.00	305,035.00	0.00	0.00

Cumulative realized capital gain and loss position from 12/31/2022 for securities held in principal of account:

Short Term: 0.00 * Long Term: 0.00 *

* The above gain and loss position does not include transactions where tax cost information is incomplete or unavailable.

Cash and securities set forth on this Account Statement are held by The Bank of New York Mellon, an affiliate of The Bank of New York Mellon Trust Company, N.A. In addition, The Bank of New York Mellon Trust Company, N.A. may utilize subsidiaries and affiliates to provide services and certain products to the Account. Subsidiaries and affiliates may be compensated for their services and products.

The value of securities set forth on this Account Statement are obtained by The Bank of New York Mellon Trust Company, N.A., from its affiliate, The Bank of New York Mellon which determines such values for Corporate Trust on the basis of market prices and information obtained by The Bank of New York Mellon from unaffiliated third parties (including independent pricing vendors) ("third party pricing services"). The Bank of New York Mellon has not verified such market values or information and makes no assurances as to the accuracy or correctness of such market values or information or that the market values set forth on this Account Statement reflect the value of the securities that can be realized upon the sale of such securities. In addition, the market values for the securities set forth in this Account Statement may differ from the market prices and information for the same securities used by other business units of The Bank of New York Mellon Trust Company, N.A., The Bank of New York Mellon or their respective subsidiaries or affiliates based upon market prices and information received from other third party pricing services utilized by such other business units. Corporate Trust does not compare its market values with those used by, or reconcile different market values used by, other business units of The Bank of New York Mellon Trust Company, N.A., The Bank of New York Mellon or their respective subsidiaries or affiliates. Neither The Bank of New York Mellon Trust Company, N.A. nor The Bank of New York Mellon shall be liable for any loss, damage or expense incurred as a result of or arising from or related to the market values or information provided by third party pricing services or the differences in market prices or information provided by other third party pricing services.



BNY MELLON

The Bank of New York Mellon Trust Company, N.A.

Go Paperless.

Securely access your accounts online to view your statements. Ask your BNY Mellon contact how we can help you access your account balances and activity in real time, receive your reports, enter your own transactions or submit an audit confirmation online. Also be sure to ask how NEXEN(SM) Gateway, our new cloud-based ecosystem, can help you.

Visit us at www.bnymellon.com

Account Statement

Statement Period 10/01/2023 Through 10/31/2023

Account 171108 Base Currency = USD
BEACH CDD 2013A REDEMPTION ACCT

CLIENT SERVICE MANAGER: CAROLINE COWART
4655 SALISBURY RD STE 300
AIM-324-0000
JACKSONVILLE, FL 32256
904-645-1919
CAROLINE.COWART@BNYMELLON.COM

Account Overview

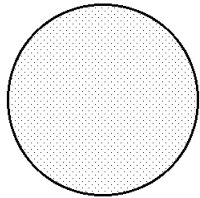

Percent of all Investments	Asset Classification	Market Value
100%	EQUITY	37.29
100%	TOTAL OF ALL INVESTMENTS	37.29

Summary of Assets Held by Asset Classification

Asset Classification	Market Value	Cost	Accrued Income	Estimated Annual Income	Market Yield
EQUITY	37.29	0.00	0.00	0.00	0.00 %
ACCOUNT TOTALS	37.29	0.00	0.00	0.00	0.00 %

Summary of Cash Transactions by Transaction Category

Transaction Category	Current Period			Year-to-Date	
	Income	Principal	Realized Gains/Losses	Income	Principal
OPENING BALANCE	0.00	0.00		0.00	0.00
CLOSING BALANCE	0.00	0.00	0.00	0.00	0.00

The above cash transactions summary is provided for information purposes only and may not reflect actual taxable income or deductible expenses as reportable under the Internal Revenue Code.



BNY MELLON

The Bank of New York Mellon Trust Company, N.A.

Statement Period 10/01/2023 Through 10/31/2023

Account 171108 Base Currency = USD

BEACH CDD 2013A REDEMPTION ACCT

Statement of Assets Held by Asset Classification

Shares/Par Value	Asset Description	Market Price	Market Value	Cost	Average Cost	Accrued Income	Estimated Income	Market Yield
EQUITY								
37.290	2013A SBA FLORIDA PRIME FD 322620 CUSIP: MM003M3HG	1.00000	37.29	0.00	0.00000	0.00	0.00	0.00%
Total EQUITY			37.29	0.00		0.00	0.00	0.00%
ACCOUNT TOTALS			37.29	0.00		0.00	0.00	0.00%

Total Market Value Plus Total Accrued Income 37.29

Statement of Transactions by Transaction Date

Transaction Date	Transaction Description	Income	Principal	Cost	Realized Gains/Losses
------------------	-------------------------	--------	-----------	------	-----------------------

No Transactions This Period

Cumulative realized capital gain and loss position from 12/31/2022 for securities held in principal of account:

Short Term: 0.00 * Long Term: 0.00 *

* The above gain and loss position does not include transactions where tax cost information is incomplete or unavailable.

Cash and securities set forth on this Account Statement are held by The Bank of New York Mellon, an affiliate of The Bank of New York Mellon Trust Company, N.A. In addition, The Bank of New York Mellon Trust Company, N.A. may utilize subsidiaries and affiliates to provide services and certain products to the Account. Subsidiaries and affiliates may be compensated for their services and products.

The value of securities set forth on this Account Statement are obtained by The Bank of New York Mellon Trust Company, N.A., from its affiliate, The Bank of New York Mellon which determines such values for Corporate Trust on the basis of market prices and information obtained by The Bank of New York Mellon from unaffiliated third parties (including independent pricing vendors) ("third party pricing services"). The Bank of New York Mellon has not verified such market values or information and makes no assurances as to the accuracy or correctness of such market values or information or that the market values set forth on this Account Statement reflect the value of the securities that can be realized upon the sale of such securities. In addition, the market values for the securities set forth in this Account Statement may differ from the market prices and information for the same securities used by other business units of The Bank of New York Mellon Trust Company, N.A., The Bank of New York Mellon or their respective subsidiaries or affiliates based upon market prices and information received from other third party pricing services utilized by such other business units. Corporate Trust does not compare its market values with those used by, or reconcile different market values used by, other business units of The Bank of New York Mellon Trust Company, N.A., The Bank of New York Mellon or their respective subsidiaries or affiliates. Neither The Bank of New York Mellon Trust Company, N.A. nor The Bank of New York Mellon shall be liable for any loss, damage or expense incurred as a result of or arising from or related to the market values or information provided by third party pricing services or the differences in market prices or information provided by other third party pricing services.



BNY MELLON

The Bank of New York Mellon Trust Company, N.A.

Account Statement

Statement Period 10/01/2023 Through 10/31/2023

Account 171120 Base Currency = USD
BEACH CDD 2013A PREPAYMENT SUBACCT

CLIENT SERVICE MANAGER: CAROLINE COWART
4655 SALISBURY RD STE 300
AIM-324-0000
JACKSONVILLE, FL 32256
904-645-1919
CAROLINE.COWART@BNYMELLON.COM

Go Paperless.

Securely access your accounts online to view your statements. Ask your BNY Mellon contact how we can help you access your account balances and activity in real time, receive your reports, enter your own transactions or submit an audit confirmation online. Also be sure to ask how NEXEN(SM) Gateway, our new cloud-based ecosystem, can help you.

Visit us at www.bnymellon.com

Account Overview

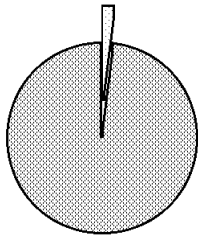

Percent of all Investments	Asset Classification	Market Value
1%	EQUITY	793.10
99%	CASH AND SHORT TERM	65,149.34
100%	TOTAL OF ALL INVESTMENTS	65,942.44

Summary of Assets Held by Asset Classification

Asset Classification	Market Value	Cost	Accrued Income	Estimated Annual Income	Market Yield
EQUITY	793.10	464.60	0.00	0.00	0.00 %
CASH AND SHORT TERM	65,149.34	65,149.34	0.00	0.00	0.00 %
ACCOUNT TOTALS	65,942.44	65,613.94	0.00	0.00	0.00 %

Summary of Cash Transactions by Transaction Category

Transaction Category	Current Period			Year-to-Date	
	Income	Principal	Realized Gains/Losses	Income	Principal
OPENING BALANCE	0.00	65,149.34		0.00	0.00
OTHER CASH ADDITIONS	0.00	0.00	0.00	0.00	81,543.14
OTHER CASH DISBURSEMENTS	0.00	0.00	0.00	0.00	16,393.80-



BNY MELLON

The Bank of New York Mellon Trust Company, N.A.

Statement Period 10/01/2023 Through 10/31/2023

Account 171120 Base Currency = USD

BEACH CDD 2013A PREPAYMENT SUBACCT

Summary of Cash Transactions by Transaction Category - Continued

Transaction Category	Current Period			Year-to-Date	
	Income	Principal	Realized Gains/Losses	Income	Principal
CLOSING BALANCE	0.00	65,149.34	0.00	0.00	65,149.34

The above cash transactions summary is provided for information purposes only and may not reflect actual taxable income or deductible expenses as reportable under the Internal Revenue Code.

e 026943 n 012892 a 02 t DOM i W1 s 50787



BNY MELLON

The Bank of New York Mellon Trust Company, N.A.

Statement Period 10/01/2023 Through 10/31/2023

Account 171120 Base Currency = USD

BEACH CDD 2013A PREPAYMENT SUBACCT

Statement of Assets Held by Asset Classification

Shares/Par Value	Asset Description	Market Price	Market Value	Cost	Average Cost	Accrued Income	Estimated Income	Market Yield
EQUITY								
793.100	2013A SBA FLORIDA PRIME FD 322620 CUSIP: MM003M3HG	1.00000	793.10	464.60	0.58580	0.00	0.00	0.00%
Total EQUITY			793.10	464.60		0.00	0.00	0.00%
CASH AND SHORT TERM								
	CASH BALANCE		65,149.34	65,149.34	0.00000	0.00	0.00	0.00%
Total CASH AND SHORT TERM			65,149.34	65,149.34		0.00	0.00	0.00%
ACCOUNT TOTALS			65,942.44	65,613.94		0.00	0.00	0.00%

Total Market Value Plus Total Accrued Income 65,942.44

Statement of Transactions by Transaction Date

Transaction Date	Transaction Description	Income	Principal	Cost	Realized Gains/Losses
------------------	-------------------------	--------	-----------	------	-----------------------

No Transactions This Period

Cumulative realized capital gain and loss position from 12/31/2022 for securities held in principal of account:

Short Term: 0.00 * Long Term: 0.00 *

* The above gain and loss position does not include transactions where tax cost information is incomplete or unavailable.

Cash and securities set forth on this Account Statement are held by The Bank of New York Mellon, an affiliate of The Bank of New York Mellon Trust Company, N.A. In addition, The Bank of New York Mellon Trust Company, N.A. may utilize subsidiaries and affiliates to provide services and certain products to the Account. Subsidiaries and affiliates may be compensated for their services and products.

The value of securities set forth on this Account Statement are obtained by The Bank of New York Mellon Trust Company, N.A., from its affiliate, The Bank of New York Mellon which determines such values for Corporate Trust on the basis of market prices and information obtained by The Bank of New York Mellon from unaffiliated third parties (including independent pricing vendors) ("third party pricing services"). The Bank of New York Mellon has not verified such market values or information and makes no assurances as to the accuracy or correctness of such market values or information or that the market values set forth on this Account Statement reflect the value of the securities that can be realized upon the sale of such securities. In addition, the market values for the securities set forth in this Account Statement may differ from the market prices and information for the same securities used by other business units of The Bank of New York Mellon Trust Company, N.A., The Bank of New York Mellon or their respective subsidiaries or affiliates based upon market prices and information received from other third party pricing services utilized by such other business units. Corporate Trust does not compare its market values with those used by, or reconcile different market values used by, other business units of The Bank of New York Mellon Trust Company, N.A., The Bank of New York Mellon or their respective subsidiaries or affiliates. Neither The Bank of New York Mellon Trust Company, N.A. nor The Bank of New York Mellon shall be liable for any loss, damage or expense incurred as a result of or arising from or related to the market values or information provided by third party pricing services or the differences in market prices or information provided by other third party pricing services.



BNY MELLON

The Bank of New York Mellon Trust Company, N.A.

Account Statement

Statement Period 10/01/2023 Through 10/31/2023

Account 171126 Base Currency = USD
BEACH CDD 2013A OPT REDEMPT SUBACCT

CLIENT SERVICE MANAGER: CAROLINE COWART
4655 SALISBURY RD STE 300
AIM-324-0000
JACKSONVILLE, FL 32256
904-645-1919
CAROLINE.COWART@BNYMELLON.COM

Go Paperless.

Securely access your accounts online to view your statements. Ask your BNY Mellon contact how we can help you access your account balances and activity in real time, receive your reports, enter your own transactions or submit an audit confirmation online. Also be sure to ask how NEXEN(SM) Gateway, our new cloud-based ecosystem, can help you.

Visit us at www.bnymellon.com

Summary of Assets Held by Asset Classification

Asset Classification	Market Value	Cost	Accrued Income	Estimated Annual Income	Market Yield
No Assets Held					

Summary of Cash Transactions by Transaction Category

Transaction Category	Current Period			Year-to-Date	
	Income	Principal	Realized Gains/Losses	Income	Principal
OPENING BALANCE	0.00	0.00		0.00	0.00
CLOSING BALANCE	0.00	0.00	0.00	0.00	0.00

The above cash transactions summary is provided for information purposes only and may not reflect actual taxable income or deductible expenses as reportable under the Internal Revenue Code.

Statement of Transactions by Transaction Date

Transaction Date	Transaction Description	Income	Principal	Cost	Realized Gains/Losses
No Transactions This Period					

Cumulative realized capital gain and loss position from 12/31/2022 for securities held in principal of account:

Short Term: 0.00 * Long Term: 0.00 *

* The above gain and loss position does not include transactions where tax cost information is incomplete or unavailable.

a 026944 n 012893 a 02 1 DOM 1 W1 S 50789



BNY MELLON

The Bank of New York Mellon Trust Company, N.A.

Statement Period 10/01/2023 Through 10/31/2023

Account 171126 Base Currency = USD
BEACH CDD 2013A OPT REDEMPT SUBACCT

Cash and securities set forth on this Account Statement are held by The Bank of New York Mellon, an affiliate of The Bank of New York Mellon Trust Company, N.A. In addition, The Bank of New York Mellon Trust Company, N.A. may utilize subsidiaries and affiliates to provide services and certain products to the Account. Subsidiaries and affiliates may be compensated for their services and products.

The value of securities set forth on this Account Statement are obtained by The Bank of New York Mellon Trust Company, N.A., from its affiliate, The Bank of New York Mellon which determines such values for Corporate Trust on the basis of market prices and information obtained by The Bank of New York Mellon from unaffiliated third parties (including independent pricing vendors) ("third party pricing services"). The Bank of New York Mellon has not verified such market values or information and makes no assurances as to the accuracy or correctness of such market values or information or that the market values set forth on this Account Statement reflect the value of the securities that can be realized upon the sale of such securities. In addition, the market values for the securities set forth in this Account Statement may differ from the market prices and information for the same securities used by other business units of The Bank of New York Mellon Trust Company, N.A., The Bank of New York Mellon or their respective subsidiaries or affiliates based upon market prices and information received from other third party pricing services utilized by such other business units. Corporate Trust does not compare its market values with those used by, or reconcile different market values used by, other business units of The Bank of New York Mellon Trust Company, N.A., The Bank of New York Mellon or their respective subsidiaries or affiliates. Neither The Bank of New York Mellon Trust Company, N.A. nor The Bank of New York Mellon shall be liable for any loss, damage or expense incurred as a result of or arising from or related to the market values or information provided by third party pricing services or the differences in market prices or information provided by other third party pricing services.

e 026944 n 012893 a 02 t DOM i WI s 50790



BNY MELLON

The Bank of New York Mellon Trust Company, N.A.

Account Statement

Statement Period 10/01/2023 Through 10/31/2023

Account 171149 Base Currency = USD
BEACH CDD 2013A REVENUE ACCT

CLIENT SERVICE MANAGER: CAROLINE COWART
4655 SALISBURY RD STE 300
AIM-324-0000
JACKSONVILLE, FL 32256
904-645-1919
CAROLINE.COWART@BNYMELLON.COM

Go Paperless.

Securely access your accounts online to view your statements. Ask your BNY Mellon contact how we can help you access your account balances and activity in real time, receive your reports, enter your own transactions or submit an audit confirmation online. Also be sure to ask how NEXEN(SM) Gateway, our new cloud-based ecosystem, can help you.

Visit us at www.bnymellon.com

Account Overview

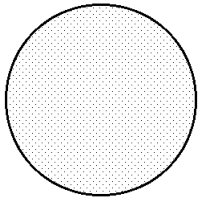

Percent of all Investments	Asset Classification	Market Value
100%	EQUITY	142,478.47
100%	TOTAL OF ALL INVESTMENTS	142,478.47

Summary of Assets Held by Asset Classification

Asset Classification	Market Value	Cost	Accrued Income	Estimated Annual Income	Market Yield
EQUITY	142,478.47	142,478.47	0.00	0.00	0.00 %
ACCOUNT TOTALS	142,478.47	142,478.47	0.00	0.00	0.00 %

Summary of Cash Transactions by Transaction Category

Transaction Category	Current Period			Year-to-Date	
	Income	Principal	Realized Gains/Losses	Income	Principal
OPENING BALANCE	0.00	118,057.53		0.00	0.00
OTHER CASH ADDITIONS	0.00	186,977.47	0.00	0.00	1,399,967.07
OTHER CASH DISBURSEMENTS	0.00	305,035.00-	0.00	0.00	1,399,967.07-



BNY MELLON

The Bank of New York Mellon Trust Company, N.A.

Statement Period 10/01/2023 Through 10/31/2023

Account 171149 Base Currency = USD

BEACH CDD 2013A REVENUE ACCT

Summary of Cash Transactions by Transaction Category - Continued

Transaction Category	Current Period			Year-to-Date	
	Income	Principal	Realized Gains/Losses	Income	Principal
CLOSING BALANCE	0.00	0.00	0.00	0.00	0.00

The above cash transactions summary is provided for information purposes only and may not reflect actual taxable income or deductible expenses as reportable under the Internal Revenue Code.

e 026951 n 012900 a 02 t DOM i W1 s 50308



BNY MELLON

The Bank of New York Mellon Trust Company, N.A.

Statement Period 10/01/2023 Through 10/31/2023

Account 171149 Base Currency = USD

BEACH CDD 2013A REVENUE ACCT

Statement of Assets Held by Asset Classification

Shares/Par Value	Asset Description	Market Price	Market Value	Cost	Average Cost	Accrued Income	Estimated Income	Market Yield
EQUITY								
142,478.470	2013A SBA FLORIDA PRIME FD 322620 CUSIP: MM003M3HG	1.00000	142,478.47	142,478.47	1.00000	0.00	0.00	0.00%
Total EQUITY			142,478.47	142,478.47		0.00	0.00	0.00%
ACCOUNT TOTALS			142,478.47	142,478.47		0.00	0.00	0.00%

Total Market Value Plus Total Accrued Income 142,478.47

Statement of Transactions by Transaction Date

Transaction Date	Transaction Description	Income	Principal	Cost	Realized Gains/Losses
10/01/23	ACCOUNT OPENING PERIOD BALANCE	0.00	118,057.53	211,596.53	
10/03/23	Receive 2013A SBA FLORIDA PRIME FD 322620 /IAS/INTEREST EARNEDAUGUST 2023 TRADE DATE 10/03/23 SET/DATE 10/03/23 CUSIP MM003M3HG 1,496.680 SHARES	0.00	0.00	1,496.68	0.00
10/03/23	Cash Credit DR PARTY: JACKSONVILLE CHECKS PROCESSING ACCT DETAIL: /BNF/CHECK RECEIVED FROM BEACH COMM DETAIL: UNITY DEVELOPMENT DISTRICT , CHECK DETAIL: NO 1217 , 1218 REL REF: CWP-2065532	0.00	4,375.72	0.00	0.00
10/03/23	ACCOUNT CLOSING DAILY BALANCE	0.00	122,433.25	213,093.21	0.00
10/30/23	Deliver 2013A SBA FLORIDA PRIME FD 322620 /IAS/DECREASE UNITS FOR NOVEMBER 1 /IAS/DS TRADE DATE 10/30/23 SET/DATE 10/30/23 CUSIP MM003M3HG 182,601.750 SHARES	0.00	0.00	70,614.74-	0.00
10/30/23	Cash Credit DR PARTY: JAX PAYMENT ACCOUNT DETAIL: /BNF/DRAW FOR 11/1 DEBT SERVICE REL REF: CWP-2142793	0.00	182,601.75	0.00	0.00

a 026951 n 012900 a 02 t DOM i WI s 50,809



BNY MELLON

The Bank of New York Mellon Trust Company, N.A.

Statement Period 10/01/2023 Through 10/31/2023

Account 171149 Base Currency = USD

BEACH CDD 2013A REVENUE ACCT

Statement of Transactions by Transaction Date - Continued

Transaction Date	Transaction Description	Income	Principal	Cost	Realized Gains/Losses
10/30/23	ACCOUNT CLOSING DAILY BALANCE	0.00	305,035.00	142,478.47	0.00
10/31/23	Cash Debit CR PARTY: BEACH CDD 2013A INTEREST ACCT DETAIL: /BNF/INTEREST DUE 11/1/2023 REL REF: TRANSFER	0.00	305,035.00-	0.00	0.00
10/31/23	ACCOUNT CLOSING DAILY BALANCE	0.00	0.00	142,478.47	0.00
10/31/23	ACCOUNT CLOSING PERIOD BALANCE	0.00	0.00	142,478.47	0.00

Cumulative realized capital gain and loss position from 12/31/2022 for securities held in principal of account:

Short Term: 0.00 * Long Term: 0.00 *

* The above gain and loss position does not include transactions where tax cost information is incomplete or unavailable.

Cash and securities set forth on this Account Statement are held by The Bank of New York Mellon, an affiliate of The Bank of New York Mellon Trust Company, N.A. In addition, The Bank of New York Mellon Trust Company, N.A. may utilize subsidiaries and affiliates to provide services and certain products to the Account. Subsidiaries and affiliates may be compensated for their services and products.

The value of securities set forth on this Account Statement are obtained by The Bank of New York Mellon Trust Company, N.A., from its affiliate, The Bank of New York Mellon which determines such values for Corporate Trust on the basis of market prices and information obtained by The Bank of New York Mellon from unaffiliated third parties (including independent pricing vendors) ("third party pricing services"). The Bank of New York Mellon has not verified such market values or information and makes no assurances as to the accuracy or correctness of such market values or information or that the market values set forth on this Account Statement reflect the value of the securities that can be realized upon the sale of such securities. In addition, the market values for the securities set forth in this Account Statement may differ from the market prices and information for the same securities used by other business units of The Bank of New York Mellon Trust Company, N.A., The Bank of New York Mellon or their respective subsidiaries or affiliates based upon market prices and information received from other third party pricing services utilized by such other business units. Corporate Trust does not compare its market values with those used by, or reconcile different market values used by, other business units of The Bank of New York Mellon Trust Company, N.A., The Bank of New York Mellon or their respective subsidiaries or affiliates. Neither The Bank of New York Mellon Trust Company, N.A. nor The Bank of New York Mellon shall be liable for any loss, damage or expense incurred as a result of or arising from or related to the market values or information provided by third party pricing services or the differences in market prices or information provided by other third party pricing services.



BNY MELLON

The Bank of New York Mellon Trust Company, N.A.

Account Statement

Statement Period 10/01/2023 Through 10/31/2023

Account 171167 Base Currency = USD
BEACH CDD 2013A REBATE ACCT

CLIENT SERVICE MANAGER: CAROLINE COWART
4655 SALISBURY RD STE 300
AIM-324-0000
JACKSONVILLE, FL 32256
904-645-1919
CAROLINE.COWART@BNYMELLON.COM

Go Paperless.

Securely access your accounts online to view your statements. Ask your BNY Mellon contact how we can help you access your account balances and activity in real time, receive your reports, enter your own transactions or submit an audit confirmation online. Also be sure to ask how NEXEN(SM) Gateway, our new cloud-based ecosystem, can help you.

Visit us at www.bnymellon.com

Summary of Assets Held by Asset Classification

Asset Classification	Market Value	Cost	Accrued Income	Estimated Annual Income	Market Yield
No Assets Held					

Summary of Cash Transactions by Transaction Category

Transaction Category	Current Period			Year-to-Date	
	Income	Principal	Realized Gains/Losses	Income	Principal
OPENING BALANCE	0.00	0.00		0.00	0.00
CLOSING BALANCE	0.00	0.00	0.00	0.00	0.00

The above cash transactions summary is provided for information purposes only and may not reflect actual taxable income or deductible expenses as reportable under the Internal Revenue Code.

Statement of Transactions by Transaction Date

Transaction Date	Transaction Description	Income	Principal	Cost	Realized Gains/Losses
No Transactions This Period					

Cumulative realized capital gain and loss position from 12/31/2022 for securities held in principal of account:

Short Term: 0.00 * Long Term: 0.00 *

* The above gain and loss position does not include transactions where tax cost information is incomplete or unavailable.



BNY MELLON

The Bank of New York Mellon Trust Company, N.A.

Statement Period 10/01/2023 Through 10/31/2023

Account 171167 Base Currency = USD

BEACH CDD 2013A REBATE ACCT

Cash and securities set forth on this Account Statement are held by The Bank of New York Mellon, an affiliate of The Bank of New York Mellon Trust Company, N.A. In addition, The Bank of New York Mellon Trust Company, N.A. may utilize subsidiaries and affiliates to provide services and certain products to the Account. Subsidiaries and affiliates may be compensated for their services and products.

The value of securities set forth on this Account Statement are obtained by The Bank of New York Mellon Trust Company, N.A., from its affiliate, The Bank of New York Mellon which determines such values for Corporate Trust on the basis of market prices and information obtained by The Bank of New York Mellon from unaffiliated third parties (including independent pricing vendors) ("third party pricing services"). The Bank of New York Mellon has not verified such market values or information and makes no assurances as to the accuracy or correctness of such market values or information or that the market values set forth on this Account Statement reflect the value of the securities that can be realized upon the sale of such securities. In addition, the market values for the securities set forth in this Account Statement may differ from the market prices and information for the same securities used by other business units of The Bank of New York Mellon Trust Company, N.A., The Bank of New York Mellon or their respective subsidiaries or affiliates based upon market prices and information received from other third party pricing services utilized by such other business units. Corporate Trust does not compare its market values with those used by, or reconcile different market values used by, other business units of The Bank of New York Mellon Trust Company, N.A., The Bank of New York Mellon or their respective subsidiaries or affiliates. Neither The Bank of New York Mellon Trust Company, N.A. nor The Bank of New York Mellon shall be liable for any loss, damage or expense incurred as a result of or arising from or related to the market values or information provided by third party pricing services or the differences in market prices or information provided by other third party pricing services.

a 026958 n 012907 a 02 t DOM i WI s 50827



BNY MELLON

The Bank of New York Mellon Trust Company, N.A.

Account Statement

Statement Period 10/01/2023 Through 10/31/2023

Account 171168 Base Currency = USD
BEACH CDD 2015A ACQ CONST SUBACCT

CLIENT SERVICE MANAGER: CAROLINE COWART
4655 SALISBURY RD STE 300
AIM-324-0000
JACKSONVILLE, FL 32256
904-645-1919
CAROLINE.COWART@BNYMELLON.COM

Go Paperless.

Securely access your accounts online to view your statements. Ask your BNY Mellon contact how we can help you access your account balances and activity in real time, receive your reports, enter your own transactions or submit an audit confirmation online. Also be sure to ask how NEXEN(SM) Gateway, our new cloud-based ecosystem, can help you.

Visit us at www.bnymellon.com

Summary of Assets Held by Asset Classification

Asset Classification	Market Value	Cost	Accrued Income	Estimated Annual Income	Market Yield
No Assets Held					

Summary of Cash Transactions by Transaction Category

Transaction Category	Current Period			Year-to-Date	
	Income	Principal	Realized Gains/Losses	Income	Principal
OPENING BALANCE	0.00	0.00		0.00	0.00
CLOSING BALANCE	0.00	0.00	0.00	0.00	0.00

The above cash transactions summary is provided for information purposes only and may not reflect actual taxable income or deductible expenses as reportable under the Internal Revenue Code.

Statement of Transactions by Transaction Date

Transaction Date	Transaction Description	Income	Principal	Cost	Realized Gains/Losses
No Transactions This Period					

Cumulative realized capital gain and loss position from 12/31/2022 for securities held in principal of account:

Short Term: 0.00 * Long Term: 0.00 *

* The above gain and loss position does not include transactions where tax cost information is incomplete or unavailable.

a 026959 n 012908 a 02 1 DOM 1 W1 S 50828



BNY MELLON

The Bank of New York Mellon Trust Company, N.A.

Statement Period 10/01/2023 Through 10/31/2023

Account 171168 Base Currency = USD
BEACH CDD 2015A ACQ CONST SUBACCT

Cash and securities set forth on this Account Statement are held by The Bank of New York Mellon, an affiliate of The Bank of New York Mellon Trust Company, N.A. In addition, The Bank of New York Mellon Trust Company, N.A. may utilize subsidiaries and affiliates to provide services and certain products to the Account. Subsidiaries and affiliates may be compensated for their services and products.

The value of securities set forth on this Account Statement are obtained by The Bank of New York Mellon Trust Company, N.A., from its affiliate, The Bank of New York Mellon which determines such values for Corporate Trust on the basis of market prices and information obtained by The Bank of New York Mellon from unaffiliated third parties (including independent pricing vendors) ("third party pricing services"). The Bank of New York Mellon has not verified such market values or information and makes no assurances as to the accuracy or correctness of such market values or information or that the market values set forth on this Account Statement reflect the value of the securities that can be realized upon the sale of such securities. In addition, the market values for the securities set forth in this Account Statement may differ from the market prices and information for the same securities used by other business units of The Bank of New York Mellon Trust Company, N.A., The Bank of New York Mellon or their respective subsidiaries or affiliates based upon market prices and information received from other third party pricing services utilized by such other business units. Corporate Trust does not compare its market values with those used by, or reconcile different market values used by, other business units of The Bank of New York Mellon Trust Company, N.A., The Bank of New York Mellon or their respective subsidiaries or affiliates. Neither The Bank of New York Mellon Trust Company, N.A. nor The Bank of New York Mellon shall be liable for any loss, damage or expense incurred as a result of or arising from or related to the market values or information provided by third party pricing services or the differences in market prices or information provided by other third party pricing services.

e 026959 n 012908 a 02 t DOM i WI s 50829



BNY MELLON

The Bank of New York Mellon Trust Company, N.A.

Account Statement

Statement Period 10/01/2023 Through 10/31/2023

Account 171170 Base Currency = USD
BEACH CDD 2015A SINKING FUND ACCT

CLIENT SERVICE MANAGER: CAROLINE COWART
4655 SALISBURY RD STE 300
AIM-324-0000
JACKSONVILLE, FL 32256
904-645-1919
CAROLINE.COWART@BNYMELLON.COM

Go Paperless.

Securely access your accounts online to view your statements. Ask your BNY Mellon contact how we can help you access your account balances and activity in real time, receive your reports, enter your own transactions or submit an audit confirmation online. Also be sure to ask how NEXEN(SM) Gateway, our new cloud-based ecosystem, can help you.

Visit us at www.bnymellon.com

Summary of Assets Held by Asset Classification

Asset Classification	Market Value	Cost	Accrued Income	Estimated Annual Income	Market Yield
No Assets Held					

Summary of Cash Transactions by Transaction Category

Transaction Category	Current Period			Year-to-Date	
	Income	Principal	Realized Gains/Losses	Income	Principal
OPENING BALANCE	0.00	0.00		0.00	0.00
OTHER CASH ADDITIONS	0.00	0.00	0.00	0.00	165,000.00
OTHER CASH DISBURSEMENTS	0.00	0.00	0.00	0.00	165,000.00 -
CLOSING BALANCE	0.00	0.00	0.00	0.00	0.00

The above cash transactions summary is provided for information purposes only and may not reflect actual taxable income or deductible expenses as reportable under the Internal Revenue Code.

Statement of Transactions by Transaction Date

Transaction Date	Transaction Description	Income	Principal	Cost	Realized Gains/Losses
No Transactions This Period					

Cumulative realized capital gain and loss position from 12/31/2022 for securities held in principal of account:

Short Term: 0.00 * Long Term: 0.00 *

* The above gain and loss position does not include transactions where tax cost information is incomplete or unavailable.



BNY MELLON

The Bank of New York Mellon Trust Company, N.A.

Statement Period 10/01/2023 Through 10/31/2023

Account 171170 Base Currency = USD

BEACH CDD 2015A SINKING FUND ACCT

Cash and securities set forth on this Account Statement are held by The Bank of New York Mellon, an affiliate of The Bank of New York Mellon Trust Company, N.A. In addition, The Bank of New York Mellon Trust Company, N.A. may utilize subsidiaries and affiliates to provide services and certain products to the Account. Subsidiaries and affiliates may be compensated for their services and products.

The value of securities set forth on this Account Statement are obtained by The Bank of New York Mellon Trust Company, N.A., from its affiliate, The Bank of New York Mellon which determines such values for Corporate Trust on the basis of market prices and information obtained by The Bank of New York Mellon from unaffiliated third parties (including independent pricing vendors) ("third party pricing services"). The Bank of New York Mellon has not verified such market values or information and makes no assurances as to the accuracy or correctness of such market values or information or that the market values set forth on this Account Statement reflect the value of the securities that can be realized upon the sale of such securities. In addition, the market values for the securities set forth in this Account Statement may differ from the market prices and information for the same securities used by other business units of The Bank of New York Mellon Trust Company, N.A., The Bank of New York Mellon or their respective subsidiaries or affiliates based upon market prices and information received from other third party pricing services utilized by such other business units. Corporate Trust does not compare its market values with those used by, or reconcile different market values used by, other business units of The Bank of New York Mellon Trust Company, N.A., The Bank of New York Mellon or their respective subsidiaries or affiliates. Neither The Bank of New York Mellon Trust Company, N.A. nor The Bank of New York Mellon shall be liable for any loss, damage or expense incurred as a result of or arising from or related to the market values or information provided by third party pricing services or the differences in market prices or information provided by other third party pricing services.



BNY MELLON

The Bank of New York Mellon Trust Company, N.A.

Go Paperless.

Securely access your accounts online to view your statements. Ask your BNY Mellon contact how we can help you access your account balances and activity in real time, receive your reports, enter your own transactions or submit an audit confirmation online. Also be sure to ask how NEXEN(SM) Gateway, our new cloud-based ecosystem, can help you.

Visit us at www.bnymellon.com

Account Statement

Statement Period 10/01/2023 Through 10/31/2023

Account 171171 Base Currency = USD
BEACH CDD 2015A INTEREST ACCT

CLIENT SERVICE MANAGER: CAROLINE COWART

4655 SALISBURY RD STE 300
AIM-324-0000
JACKSONVILLE, FL 32256
904-645-1919
CAROLINE.COWART@BNYMELLON.COM

Account Overview

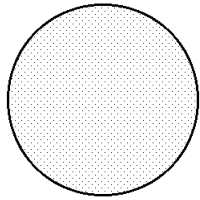

Percent of all Investments	Asset Classification	Market Value
100%	CASH AND SHORT TERM	217,120.00
100%	TOTAL OF ALL INVESTMENTS	217,120.00

Summary of Assets Held by Asset Classification

Asset Classification	Market Value	Cost	Accrued Income	Estimated Annual Income	Market Yield
CASH AND SHORT TERM	217,120.00	217,120.00	0.00	0.00	0.00 %
ACCOUNT TOTALS	217,120.00	217,120.00	0.00	0.00	0.00 %

Summary of Cash Transactions by Transaction Category

Transaction Category	Current Period			Year-to-Date	
	Income	Principal	Realized Gains/Losses	Income	Principal
OPENING BALANCE	0.00	0.00		0.00	0.00
OTHER CASH ADDITIONS	0.00	217,120.00	0.00	0.00	439,107.50
OTHER CASH DISBURSEMENTS	0.00	0.00	0.00	0.00	221,987.50-



BNY MELLON

The Bank of New York Mellon Trust Company, N.A.

Statement Period 10/01/2023 Through 10/31/2023

Account 171171 Base Currency = USD

BEACH CDD 2015A INTEREST ACCT

Summary of Cash Transactions by Transaction Category - Continued

Transaction Category	Current Period			Year-to-Date	
	Income	Principal	Realized Gains/Losses	Income	Principal
CLOSING BALANCE	0.00	217,120.00	0.00	0.00	217,120.00

The above cash transactions summary is provided for information purposes only and may not reflect actual taxable income or deductible expenses as reportable under the Internal Revenue Code.

e 026961 n 012910 a 02 t DOM i W1 s 50333



BNY MELLON

The Bank of New York Mellon Trust Company, N.A.

Statement Period 10/01/2023 Through 10/31/2023

Account 171171 Base Currency = USD

BEACH CDD 2015A INTEREST ACCT

Statement of Assets Held by Asset Classification

Shares/Par Value	Asset Description	Market Price	Market Value	Cost	Average Cost	Accrued Income	Estimated Income	Market Yield
CASH AND SHORT TERM								
	CASH BALANCE		217,120.00	217,120.00	0.00000	0.00	0.00	0.00%
Total CASH AND SHORT TERM			217,120.00	217,120.00		0.00	0.00	0.00%
ACCOUNT TOTALS			217,120.00	217,120.00		0.00	0.00	0.00%

Total Market Value Plus Total Accrued Income 217,120.00

Statement of Transactions by Transaction Date

Transaction Date	Transaction Description	Income	Principal	Cost	Realized Gains/Losses
10/01/23	ACCOUNT OPENING PERIOD BALANCE	0.00	0.00	0.00	
10/31/23	Cash Credit DR PARTY: BEACH CDD 2015A REVENUE ACCT DETAIL: /BNF/REP INTEREST DUE 11/1/2023 REL REF: CWP-2148798	0.00	217,120.00	0.00	0.00
10/31/23	ACCOUNT CLOSING DAILY BALANCE	0.00	217,120.00	0.00	0.00
10/31/23	ACCOUNT CLOSING PERIOD BALANCE	0.00	217,120.00	0.00	0.00

Cumulative realized capital gain and loss position from 12/31/2022 for securities held in principal of account:

Short Term: 0.00 * Long Term: 0.00 *

* The above gain and loss position does not include transactions where tax cost information is incomplete or unavailable.

Cash and securities set forth on this Account Statement are held by The Bank of New York Mellon, an affiliate of The Bank of New York Mellon Trust Company, N.A. In addition, The Bank of New York Mellon Trust Company, N.A. may utilize subsidiaries and affiliates to provide services and certain products to the Account. Subsidiaries and affiliates may be compensated for their services and products.

The value of securities set forth on this Account Statement are obtained by The Bank of New York Mellon Trust Company, N.A., from its affiliate, The Bank of New York Mellon which determines such values for Corporate Trust on the basis of market prices and information obtained by The Bank of New York Mellon from unaffiliated third parties (including independent pricing vendors) ("third party pricing services"). The Bank of New York Mellon has not verified such market values or information and makes no assurances as to the accuracy or correctness of such market values or information or that the market values set forth on this Account Statement reflect the value of the securities that can be realized upon the sale of such securities. In addition, the market values for the securities set forth in this Account Statement may differ from the market prices and information for the same securities used by other business units of The Bank of New York Mellon Trust Company, N.A., The Bank of New York Mellon or their respective subsidiaries or affiliates based upon market prices and information received from other third party pricing services utilized by such other business units. Corporate Trust does not compare its market values with those used by, or reconcile different market values used by, other business units of The Bank of New York Mellon Trust Company, N.A., The Bank of New York Mellon or their respective subsidiaries or affiliates. Neither The Bank of New York Mellon Trust Company, N.A. nor The Bank of New York Mellon shall be liable for any loss, damage or expense incurred as a result of or arising from or related to the market values or information provided by third party pricing services or the differences in market prices or information provided by other third party pricing services.



BNY MELLON

The Bank of New York Mellon Trust Company, N.A.

Go Paperless.

Securely access your accounts online to view your statements. Ask your BNY Mellon contact how we can help you access your account balances and activity in real time, receive your reports, enter your own transactions or submit an audit confirmation online. Also be sure to ask how NEXEN(SM) Gateway, our new cloud-based ecosystem, can help you.

Visit us at www.bnymellon.com

Account Statement

Statement Period 10/01/2023 Through 10/31/2023

Account 171172 Base Currency = USD
BEACH CDD 2015A REDEMPTION ACCT

CLIENT SERVICE MANAGER: CAROLINE COWART

4655 SALISBURY RD STE 300
AIM-324-0000
JACKSONVILLE, FL 32256
904-645-1919
CAROLINE.COWART@BNYMELLON.COM

Account Overview

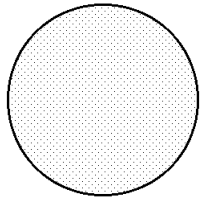

Percent of all Investments	Asset Classification	Market Value
100%	EQUITY	149.42
100%	TOTAL OF ALL INVESTMENTS	149.42

Summary of Assets Held by Asset Classification

Asset Classification	Market Value	Cost	Accrued Income	Estimated Annual Income	Market Yield
EQUITY	149.42	149.42	0.00	0.00	0.00 %
ACCOUNT TOTALS	149.42	149.42	0.00	0.00	0.00 %

Summary of Cash Transactions by Transaction Category

Transaction Category	Current Period			Year-to-Date	
	Income	Principal	Realized Gains/Losses	Income	Principal
OPENING BALANCE	0.00	0.00		0.00	0.00
OTHER CASH ADDITIONS	0.00	0.00	0.00	0.00	17,110.07
OTHER CASH DISBURSEMENTS	0.00	0.00	0.00	0.00	17,110.07-



BNY MELLON

The Bank of New York Mellon Trust Company, N.A.

Statement Period 10/01/2023 Through 10/31/2023

Account 171172 Base Currency = USD

BEACH CDD 2015A REDEMPTION ACCT

Summary of Cash Transactions by Transaction Category - Continued

Transaction Category	Current Period			Year-to-Date	
	Income	Principal	Realized Gains/Losses	Income	Principal
CLOSING BALANCE	0.00	0.00	0.00	0.00	0.00

The above cash transactions summary is provided for information purposes only and may not reflect actual taxable income or deductible expenses as reportable under the Internal Revenue Code.



BNY MELLON

The Bank of New York Mellon Trust Company, N.A.

Statement Period 10/01/2023 Through 10/31/2023

Account 171172 Base Currency = USD
BEACH CDD 2015A REDEMPTION ACCT

Statement of Assets Held by Asset Classification

Shares/Par Value	Asset Description	Market Price	Market Value	Cost	Average Cost	Accrued Income	Estimated Income	Market Yield
EQUITY								
149.420	2015A SBA FLORIDA PRIME FD 322622 CUSIP: MM003M3H6	1.00000	149.42	149.42	1.00000	0.00	0.00	0.00%
Total EQUITY			149.42	149.42		0.00	0.00	0.00%
ACCOUNT TOTALS			149.42	149.42		0.00	0.00	0.00%

Total Market Value Plus Total Accrued Income 149.42

Statement of Transactions by Transaction Date

Transaction Date	Transaction Description	Income	Principal	Cost	Realized Gains/Losses
------------------	-------------------------	--------	-----------	------	-----------------------

No Transactions This Period

Cumulative realized capital gain and loss position from 12/31/2022 for securities held in principal of account:

Short Term: 0.00 * Long Term: 0.00 *

* The above gain and loss position does not include transactions where tax cost information is incomplete or unavailable.

Cash and securities set forth on this Account Statement are held by The Bank of New York Mellon, an affiliate of The Bank of New York Mellon Trust Company, N.A. In addition, The Bank of New York Mellon Trust Company, N.A. may utilize subsidiaries and affiliates to provide services and certain products to the Account. Subsidiaries and affiliates may be compensated for their services and products.

The value of securities set forth on this Account Statement are obtained by The Bank of New York Mellon Trust Company, N.A., from its affiliate, The Bank of New York Mellon which determines such values for Corporate Trust on the basis of market prices and information obtained by The Bank of New York Mellon from unaffiliated third parties (including independent pricing vendors) ("third party pricing services"). The Bank of New York Mellon has not verified such market values or information and makes no assurances as to the accuracy or correctness of such market values or information or that the market values set forth on this Account Statement reflect the value of the securities that can be realized upon the sale of such securities. In addition, the market values for the securities set forth in this Account Statement may differ from the market prices and information for the same securities used by other business units of The Bank of New York Mellon Trust Company, N.A., The Bank of New York Mellon or their respective subsidiaries or affiliates based upon market prices and information received from other third party pricing services utilized by such other business units. Corporate Trust does not compare its market values with those used by, or reconcile different market values used by, other business units of The Bank of New York Mellon Trust Company, N.A., The Bank of New York Mellon or their respective subsidiaries or affiliates. Neither The Bank of New York Mellon Trust Company, N.A. nor The Bank of New York Mellon shall be liable for any loss, damage or expense incurred as a result of or arising from or related to the market values or information provided by third party pricing services or the differences in market prices or information provided by other third party pricing services.



BNY MELLON

The Bank of New York Mellon Trust Company, N.A.

Account Statement

Statement Period 10/01/2023 Through 10/31/2023

Account 171173 Base Currency = USD
BEACH CDD 2015A PREPAYMENT SUBACCT

CLIENT SERVICE MANAGER: CAROLINE COWART
4655 SALISBURY RD STE 300
AIM-324-0000
JACKSONVILLE, FL 32256
904-645-1919
CAROLINE.COWART@BNYMELLON.COM

Go Paperless.

Securely access your accounts online to view your statements. Ask your BNY Mellon contact how we can help you access your account balances and activity in real time, receive your reports, enter your own transactions or submit an audit confirmation online. Also be sure to ask how NEXEN(SM) Gateway, our new cloud-based ecosystem, can help you.

Visit us at www.bnymellon.com

Account Overview

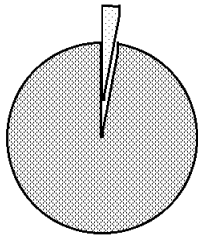

Percent of all Investments	Asset Classification	Market Value
2%	EQUITY	3,239.22
98%	CASH AND SHORT TERM	109,808.53
100%	TOTAL OF ALL INVESTMENTS	113,047.75

Summary of Assets Held by Asset Classification

Asset Classification	Market Value	Cost	Accrued Income	Estimated Annual Income	Market Yield
EQUITY	3,239.22	1,934.92	0.00	0.00	0.00 %
CASH AND SHORT TERM	109,808.53	109,808.53	0.00	0.00	0.00 %
ACCOUNT TOTALS	113,047.75	111,743.45	0.00	0.00	0.00 %

Summary of Cash Transactions by Transaction Category

Transaction Category	Current Period			Year-to-Date	
	Income	Principal	Realized Gains/Losses	Income	Principal
OPENING BALANCE	0.00	76,872.62		0.00	1,934.92
OTHER CASH ADDITIONS	0.00	32,935.91	0.00	0.00	113,678.37
OTHER CASH DISBURSEMENTS	0.00	0.00	0.00	0.00	5,804.76-



BNY MELLON

The Bank of New York Mellon Trust Company, N.A.

Statement Period 10/01/2023 Through 10/31/2023

Account 171173 Base Currency = USD

BEACH CDD 2015A PREPAYMENT SUBACCT

Summary of Cash Transactions by Transaction Category - Continued

Transaction Category	Current Period			Year-to-Date	
	Income	Principal	Realized Gains/Losses	Income	Principal
CLOSING BALANCE	0.00	109,808.53	0.00	0.00	109,808.53

The above cash transactions summary is provided for information purposes only and may not reflect actual taxable income or deductible expenses as reportable under the Internal Revenue Code.

e 026963 n 012912 a 02 t DOM i W1 s 50339



BNY MELLON

The Bank of New York Mellon Trust Company, N.A.

Statement Period 10/01/2023 Through 10/31/2023

Account 171173 Base Currency = USD

BEACH CDD 2015A PREPAYMENT SUBACCT

Statement of Assets Held by Asset Classification

Shares/Par Value	Asset Description	Market Price	Market Value	Cost	Average Cost	Accrued Income	Estimated Income	Market Yield
EQUITY								
3,239.220	2015A SBA FLORIDA PRIME FD 322622 CUSIP: MM003M3H6	1.00000	3,239.22	1,934.92	0.59734	0.00	0.00	0.00%
Total EQUITY			3,239.22	1,934.92		0.00	0.00	0.00%
CASH AND SHORT TERM								
	CASH BALANCE		109,808.53	109,808.53	0.00000	0.00	0.00	0.00%
Total CASH AND SHORT TERM			109,808.53	109,808.53		0.00	0.00	0.00%
ACCOUNT TOTALS			113,047.75	111,743.45		0.00	0.00	0.00%

Total Market Value Plus Total Accrued Income 113,047.75

Statement of Transactions by Transaction Date

Transaction Date	Transaction Description	Income	Principal	Cost	Realized Gains/Losses
10/01/23	ACCOUNT OPENING PERIOD BALANCE	0.00	76,872.62	1,934.92	
10/31/23	Cash Credit DR PARTY: JACKSONVILLE CHECKS PROCESSING ACCT DETAIL: /BNF/CHECK RECEIVED FROM TAMAYA PRO DETAIL: PERTY HOLDING LLC , CHECK NO 006337 REL REF: CWP-2142403	0.00	32,935.91	0.00	0.00
10/31/23	ACCOUNT CLOSING DAILY BALANCE	0.00	109,808.53	1,934.92	0.00
10/31/23	ACCOUNT CLOSING PERIOD BALANCE	0.00	109,808.53	1,934.92	0.00

Cumulative realized capital gain and loss position from 12/31/2022 for securities held in principal of account:

Short Term: 0.00 * Long Term: 0.00 *

* The above gain and loss position does not include transactions where tax cost information is incomplete or unavailable.

a 026963 n 012912 a 02 1 DOM 1 W1 S 50840



BNY MELLON

The Bank of New York Mellon Trust Company, N.A.

Statement Period 10/01/2023 Through 10/31/2023

Account 171173

Base Currency = USD

BEACH CDD 2015A PREPAYMENT SUBACCT

Cash and securities set forth on this Account Statement are held by The Bank of New York Mellon, an affiliate of The Bank of New York Mellon Trust Company, N.A. In addition, The Bank of New York Mellon Trust Company, N.A. may utilize subsidiaries and affiliates to provide services and certain products to the Account. Subsidiaries and affiliates may be compensated for their services and products.

The value of securities set forth on this Account Statement are obtained by The Bank of New York Mellon Trust Company, N.A., from its affiliate, The Bank of New York Mellon which determines such values for Corporate Trust on the basis of market prices and information obtained by The Bank of New York Mellon from unaffiliated third parties (including independent pricing vendors) ("third party pricing services"). The Bank of New York Mellon has not verified such market values or information and makes no assurances as to the accuracy or correctness of such market values or information or that the market values set forth on this Account Statement reflect the value of the securities that can be realized upon the sale of such securities. In addition, the market values for the securities set forth in this Account Statement may differ from the market prices and information for the same securities used by other business units of The Bank of New York Mellon Trust Company, N.A., The Bank of New York Mellon or their respective subsidiaries or affiliates based upon market prices and information received from other third party pricing services utilized by such other business units. Corporate Trust does not compare its market values with those used by, or reconcile different market values used by, other business units of The Bank of New York Mellon Trust Company, N.A., The Bank of New York Mellon or their respective subsidiaries or affiliates. Neither The Bank of New York Mellon Trust Company, N.A. nor The Bank of New York Mellon shall be liable for any loss, damage or expense incurred as a result of or arising from or related to the market values or information provided by third party pricing services or the differences in market prices or information provided by other third party pricing services.

e 026963 n 012912 a 02 t DOM i WI s 50&41



BNY MELLON

The Bank of New York Mellon Trust Company, N.A.

Go Paperless.

Securely access your accounts online to view your statements. Ask your BNY Mellon contact how we can help you access your account balances and activity in real time, receive your reports, enter your own transactions or submit an audit confirmation online. Also be sure to ask how NEXEN(SM) Gateway, our new cloud-based ecosystem, can help you.

Visit us at www.bnymellon.com

Account Statement

Statement Period 10/01/2023 Through 10/31/2023

Account 171175 Base Currency = USD
BEACH CDD 2015A OPT REDEMPT SUBACCT

CLIENT SERVICE MANAGER: CAROLINE COWART
4655 SALISBURY RD STE 300
AIM-324-0000
JACKSONVILLE, FL 32256
904-645-1919
CAROLINE.COWART@BNYMELLON.COM

Account Overview

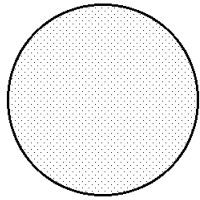

Percent of all Investments	Asset Classification	Market Value
100%	EQUITY	0.27
100%	TOTAL OF ALL INVESTMENTS	0.27

Summary of Assets Held by Asset Classification

Asset Classification	Market Value	Cost	Accrued Income	Estimated Annual Income	Market Yield
EQUITY	0.27	0.00	0.00	0.00	0.00 %
ACCOUNT TOTALS	0.27	0.00	0.00	0.00	0.00 %

Summary of Cash Transactions by Transaction Category

Transaction Category	Current Period			Year-to-Date	
	Income	Principal	Realized Gains/Losses	Income	Principal
OPENING BALANCE	0.00	0.00		0.00	0.00
CLOSING BALANCE	0.00	0.00	0.00	0.00	0.00

The above cash transactions summary is provided for information purposes only and may not reflect actual taxable income or deductible expenses as reportable under the Internal Revenue Code.



BNY MELLON

The Bank of New York Mellon Trust Company, N.A.

Statement Period 10/01/2023 Through 10/31/2023

Account 171175

Base Currency = USD

BEACH CDD 2015A OPT REDEMPT SUBACCT

Statement of Assets Held by Asset Classification

Shares/Par Value	Asset Description	Market Price	Market Value	Cost	Average Cost	Accrued Income	Estimated Income	Market Yield
EQUITY								
0.270	2015A SBA FLORIDA PRIME FD 322622 CUSIP: MM003M3H6	1.00000	0.27	0.00	0.00000	0.00	0.00	0.00%
Total EQUITY			0.27	0.00		0.00	0.00	0.00%
ACCOUNT TOTALS			0.27	0.00		0.00	0.00	0.00%

Total Market Value Plus Total Accrued Income 0.27

Statement of Transactions by Transaction Date

Transaction Date	Transaction Description	Income	Principal	Cost	Realized Gains/Losses
------------------	-------------------------	--------	-----------	------	-----------------------

No Transactions This Period

Cumulative realized capital gain and loss position from 12/31/2022 for securities held in principal of account:

Short Term: 0.00 * Long Term: 0.00 *

* The above gain and loss position does not include transactions where tax cost information is incomplete or unavailable.

Cash and securities set forth on this Account Statement are held by The Bank of New York Mellon, an affiliate of The Bank of New York Mellon Trust Company, N.A. In addition, The Bank of New York Mellon Trust Company, N.A. may utilize subsidiaries and affiliates to provide services and certain products to the Account. Subsidiaries and affiliates may be compensated for their services and products.

The value of securities set forth on this Account Statement are obtained by The Bank of New York Mellon Trust Company, N.A., from its affiliate, The Bank of New York Mellon which determines such values for Corporate Trust on the basis of market prices and information obtained by The Bank of New York Mellon from unaffiliated third parties (including independent pricing vendors) ("third party pricing services"). The Bank of New York Mellon has not verified such market values or information and makes no assurances as to the accuracy or correctness of such market values or information or that the market values set forth on this Account Statement reflect the value of the securities that can be realized upon the sale of such securities. In addition, the market values for the securities set forth in this Account Statement may differ from the market prices and information for the same securities used by other business units of The Bank of New York Mellon Trust Company, N.A., The Bank of New York Mellon or their respective subsidiaries or affiliates based upon market prices and information received from other third party pricing services utilized by such other business units. Corporate Trust does not compare its market values with those used by, or reconcile different market values used by, other business units of The Bank of New York Mellon Trust Company, N.A., The Bank of New York Mellon or their respective subsidiaries or affiliates. Neither The Bank of New York Mellon Trust Company, N.A. nor The Bank of New York Mellon shall be liable for any loss, damage or expense incurred as a result of or arising from or related to the market values or information provided by third party pricing services or the differences in market prices or information provided by other third party pricing services.



BNY MELLON

The Bank of New York Mellon Trust Company, N.A.

Go Paperless.

Securely access your accounts online to view your statements. Ask your BNY Mellon contact how we can help you access your account balances and activity in real time, receive your reports, enter your own transactions or submit an audit confirmation online. Also be sure to ask how NEXEN(SM) Gateway, our new cloud-based ecosystem, can help you.

Visit us at www.bnymellon.com

Account Statement

Statement Period 10/01/2023 Through 10/31/2023

Account 171177 Base Currency = USD
BEACH CDD 2015A REVENUE ACCT

CLIENT SERVICE MANAGER: CAROLINE COWART

4655 SALISBURY RD STE 300
AIM-324-0000
JACKSONVILLE, FL 32256
904-645-1919
CAROLINE.COWART@BNYMELLON.COM

Account Overview

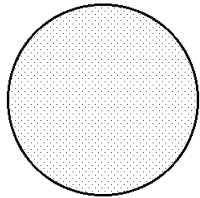

Percent of all Investments	Asset Classification	Market Value
100%	EQUITY	5,934.63
100%	TOTAL OF ALL INVESTMENTS	5,934.63

Summary of Assets Held by Asset Classification

Asset Classification	Market Value	Cost	Accrued Income	Estimated Annual Income	Market Yield
EQUITY	5,934.63	5,934.63	0.00	0.00	0.00 %
ACCOUNT TOTALS	5,934.63	5,934.63	0.00	0.00	0.00 %

Summary of Cash Transactions by Transaction Category

Transaction Category	Current Period			Year-to-Date	
	Income	Principal	Realized Gains/Losses	Income	Principal
OPENING BALANCE	0.00	51,237.53		0.00	6,236.72
OTHER CASH ADDITIONS	0.00	165,882.47	0.00	0.00	824,260.08
OTHER CASH DISBURSEMENTS	0.00	217,120.00-	0.00	0.00	830,496.80-



BNY MELLON

The Bank of New York Mellon Trust Company, N.A.

Statement Period 10/01/2023 Through 10/31/2023

Account 171177 Base Currency = USD

BEACH CDD 2015A REVENUE ACCT

Summary of Cash Transactions by Transaction Category - Continued

Transaction Category	Current Period			Year-to-Date	
	Income	Principal	Realized Gains/Losses	Income	Principal
CLOSING BALANCE	0.00	0.00	0.00	0.00	0.00

The above cash transactions summary is provided for information purposes only and may not reflect actual taxable income or deductible expenses as reportable under the Internal Revenue Code.

e 026965 n 012914 a 02 t DOM i W1 s 50,845



BNY MELLON

The Bank of New York Mellon Trust Company, N.A.

Statement Period 10/01/2023 Through 10/31/2023

Account 171177 Base Currency = USD

BEACH CDD 2015A REVENUE ACCT

Statement of Assets Held by Asset Classification

Shares/Par Value	Asset Description	Market Price	Market Value	Cost	Average Cost	Accrued Income	Estimated Income	Market Yield
EQUITY								
5,934.630	2015A SBA FLORIDA PRIME FD 322622 CUSIP: MM003M3H6	1.00000	5,934.63	5,934.63	1.00000	0.00	0.00	0.00%
Total EQUITY			5,934.63	5,934.63		0.00	0.00	0.00%
ACCOUNT TOTALS			5,934.63	5,934.63		0.00	0.00	0.00%

Total Market Value Plus Total Accrued Income 5,934.63

Statement of Transactions by Transaction Date

Transaction Date	Transaction Description	Income	Principal	Cost	Realized Gains/Losses
10/01/23	ACCOUNT OPENING PERIOD BALANCE	0.00	51,237.53	76,453.30	
10/03/23	Receive 2015A SBA FLORIDA PRIME FD 322622 /IAS/INTEREST EARNEDAUGUST 2023 TRADE DATE 10/03/23 SET/DATE 10/03/23 CUSIP MM003M3H6 368.620 SHARES	0.00	0.00	368.62	0.00
10/03/23	Cash Credit DR PARTY: JACKSONVILLE CHECKS PROCESSING ACCT DETAIL: /BNF/CHECK RECEIVED FROM BEACH COMM DETAIL: UNITY DEVELOPMENT DISTRICT , CHECK DETAIL: NO 1217 , 1218 REL REF: CWP-2065533	0.00	2,011.23	0.00	0.00
10/03/23	ACCOUNT CLOSING DAILY BALANCE	0.00	53,248.76	76,821.92	0.00
10/31/23	Deliver 2015A SBA FLORIDA PRIME FD 322622 /IAS/DECREASE UNITS FOR NOVEMBER 1 /IAS/DS TRADE DATE 10/31/23 SET/DATE 10/31/23 CUSIP MM003M3H6 70,933.440 SHARES	0.00	0.00	70,887.29-	0.00
10/31/23	Cash Credit DR PARTY: JACKSONVILLE CHECKS PROCESSING ACCT DETAIL: /BNF/CHECK RECEIVED FROM TAMAYA PRO DETAIL: PERTY HOLDING LLC , CHECK NO	0.00	92,937.80	0.00	0.00

a 026965 n 012914 a 02 t DOM i WI s 50,846



BNY MELLON

The Bank of New York Mellon Trust Company, N.A.

Statement Period 10/01/2023 Through 10/31/2023

Account 171177 Base Currency = USD

BEACH CDD 2015A REVENUE ACCT

Statement of Transactions by Transaction Date - Continued

Transaction Date	Transaction Description	Income	Principal	Cost	Realized Gains/Losses
10/31/23	006346 REL REF: CWP-2142404 Cash Credit DR PARTY: JAX PAYMENT ACCOUNT DETAIL: /BNF/REP DRAW FOR 11/1/2023 DEBT SE	0.00	70,933.44	0.00	0.00
10/31/23	DETAIL: RVICE REL REF: CWP-2148787 Cash Debit CR PARTY: BEACH CDD 2015A INTEREST ACCT DETAIL: /BNF/REP INTEREST DUE 11/1/2023 REL REF: TRANSFER	0.00	217,120.00-	0.00	0.00
10/31/23	ACCOUNT CLOSING DAILY BALANCE	0.00	0.00	5,934.63	0.00
10/31/23	ACCOUNT CLOSING PERIOD BALANCE	0.00	0.00	5,934.63	0.00

Cumulative realized capital gain and loss position from 12/31/2022 for securities held in principal of account:

Short Term: 0.00 * Long Term: 0.00 *

* The above gain and loss position does not include transactions where tax cost information is incomplete or unavailable.

Cash and securities set forth on this Account Statement are held by The Bank of New York Mellon, an affiliate of The Bank of New York Mellon Trust Company, N.A. In addition, The Bank of New York Mellon Trust Company, N.A. may utilize subsidiaries and affiliates to provide services and certain products to the Account. Subsidiaries and affiliates may be compensated for their services and products.

The value of securities set forth on this Account Statement are obtained by The Bank of New York Mellon Trust Company, N.A., from its affiliate, The Bank of New York Mellon which determines such values for Corporate Trust on the basis of market prices and information obtained by The Bank of New York Mellon from unaffiliated third parties (including independent pricing vendors) ("third party pricing services"). The Bank of New York Mellon has not verified such market values or information and makes no assurances as to the accuracy or correctness of such market values or information or that the market values set forth on this Account Statement reflect the value of the securities that can be realized upon the sale of such securities. In addition, the market values for the securities set forth in this Account Statement may differ from the market prices and information for the same securities used by other business units of The Bank of New York Mellon Trust Company, N.A., The Bank of New York Mellon or their respective subsidiaries or affiliates based upon market prices and information received from other third party pricing services utilized by such other business units. Corporate Trust does not compare its market values with those used by, or reconcile different market values used by, other business units of The Bank of New York Mellon Trust Company, N.A., The Bank of New York Mellon or their respective subsidiaries or affiliates. Neither The Bank of New York Mellon Trust Company, N.A. nor The Bank of New York Mellon shall be liable for any loss, damage or expense incurred as a result of or arising from or related to the market values or information provided by third party pricing services or the differences in market prices or information provided by other third party pricing services.



BNY MELLON

The Bank of New York Mellon Trust Company, N.A.

Account Statement

Statement Period 10/01/2023 Through 10/31/2023

Account 171178 Base Currency = USD
BEACH CDD 2015A REBATE ACCT

CLIENT SERVICE MANAGER: CAROLINE COWART
4655 SALISBURY RD STE 300
AIM-324-0000
JACKSONVILLE, FL 32256
904-645-1919
CAROLINE.COWART@BNYMELLON.COM

Go Paperless.

Securely access your accounts online to view your statements. Ask your BNY Mellon contact how we can help you access your account balances and activity in real time, receive your reports, enter your own transactions or submit an audit confirmation online. Also be sure to ask how NEXEN(SM) Gateway, our new cloud-based ecosystem, can help you.

Visit us at www.bnymellon.com

Summary of Assets Held by Asset Classification

Asset Classification	Market Value	Cost	Accrued Income	Estimated Annual Income	Market Yield
No Assets Held					

Summary of Cash Transactions by Transaction Category

Transaction Category	Current Period			Year-to-Date	
	Income	Principal	Realized Gains/Losses	Income	Principal
OPENING BALANCE	0.00	0.00		0.00	0.00
CLOSING BALANCE	0.00	0.00	0.00	0.00	0.00

The above cash transactions summary is provided for information purposes only and may not reflect actual taxable income or deductible expenses as reportable under the Internal Revenue Code.

Statement of Transactions by Transaction Date

Transaction Date	Transaction Description	Income	Principal	Cost	Realized Gains/Losses
No Transactions This Period					

Cumulative realized capital gain and loss position from 12/31/2022 for securities held in principal of account:

Short Term: 0.00 * Long Term: 0.00 *

* The above gain and loss position does not include transactions where tax cost information is incomplete or unavailable.



BNY MELLON

The Bank of New York Mellon Trust Company, N.A.

Statement Period 10/01/2023 Through 10/31/2023

Account 171178

Base Currency = USD

BEACH CDD 2015A REBATE ACCT

Cash and securities set forth on this Account Statement are held by The Bank of New York Mellon, an affiliate of The Bank of New York Mellon Trust Company, N.A. In addition, The Bank of New York Mellon Trust Company, N.A. may utilize subsidiaries and affiliates to provide services and certain products to the Account. Subsidiaries and affiliates may be compensated for their services and products.

The value of securities set forth on this Account Statement are obtained by The Bank of New York Mellon Trust Company, N.A., from its affiliate, The Bank of New York Mellon which determines such values for Corporate Trust on the basis of market prices and information obtained by The Bank of New York Mellon from unaffiliated third parties (including independent pricing vendors) ("third party pricing services"). The Bank of New York Mellon has not verified such market values or information and makes no assurances as to the accuracy or correctness of such market values or information or that the market values set forth on this Account Statement reflect the value of the securities that can be realized upon the sale of such securities. In addition, the market values for the securities set forth in this Account Statement may differ from the market prices and information for the same securities used by other business units of The Bank of New York Mellon Trust Company, N.A., The Bank of New York Mellon or their respective subsidiaries or affiliates based upon market prices and information received from other third party pricing services utilized by such other business units. Corporate Trust does not compare its market values with those used by, or reconcile different market values used by, other business units of The Bank of New York Mellon Trust Company, N.A., The Bank of New York Mellon or their respective subsidiaries or affiliates. Neither The Bank of New York Mellon Trust Company, N.A. nor The Bank of New York Mellon shall be liable for any loss, damage or expense incurred as a result of or arising from or related to the market values or information provided by third party pricing services or the differences in market prices or information provided by other third party pricing services.

a 026966 n 012915 a 02 t DOM i WI s 50849

EXHIBIT 7



This agreement dated _____, is made between **Charles Aquatics, Inc.**, a Florida Corporation, and

Name Tamaya (Beach CDD) c/o David C. McInnes - Vesta District Services

Address 250 International Parkway, Suite 208

City Lake Mary State FL Zip 32746

Phone 321-263-0132 ext. 193 Fax _____

E-mail dmcinnes@vestapropertyservices.com

Hereinafter called "CLIENT".

1. **Charles Aquatics, Inc.**, agrees to provide fountain repair services in accordance with the terms and conditions of this Agreement at the following location(s): **Tamaya, Jacksonville, FL**
2. CLIENT agrees to pay **Charles Aquatics, Inc.**, the following sum(s) for the listed fountain services:

Fountain Repair: Replace the 5hp 230v 1ph Motor, Motor Starter Control Box and the Submersible Turbine Pump. **1 Year Warranty**

\$ 5,052.00

1. Client agrees to pay the balance in full within 10 days of installation. Client agrees to pay 1.5% of unpaid sum(s) after 30 days of installation. This quote is valid for 30 days.

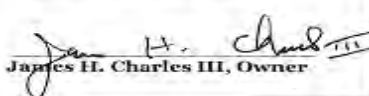
Charles Aquatics, Inc.

 James H. Charles III, Owner

Representative of Charles Aquatics, Inc. 10-24-23
Date

Customer Signature _____ Date

EXHIBIT 8



This agreement dated _____, is made between **Charles Aquatics, Inc.**, a Florida Corporation, and

Name Tamaya (Beach CDD) c/o David C. McInnes - Vesta District Services

Address 250 International Parkway, Suite 208

City Lake Mary State FL Zip 32746

Phone 321-263-0132 ext. 193 Fax _____

E-mail dmcinnes@vestapropertyservices.com

Hereinafter called "CLIENT".

1. **Charles Aquatics, Inc.**, agrees to provide fountain services in accordance with the terms and conditions of this Agreement at the following location(s): **Tamaya, Jacksonville, FL**
2. CLIENT agrees to pay **Charles Aquatics, Inc.**, the following sum(s) for the listed fountain services:

Fountain: Provide and install one Kasco 2hp 230v 1ph Fountain with Control Panel, 150ft of Power Cable and 6 standard nozzles (Linden, Balsam, Redwood, Spruce, and Birch). FOUNTAIN PACKAGE CARRIES A 3-YEAR MANUFACTURER WARRANTY

\$ 7,664.00

Optional Premium Nozzles: Mighty Oak, Madrone, Magnolia, Mahogany and Palm.

\$ 269.00

Lighting Options: LED LIGHTS CARRIES A 2- YEAR MANUFACTURER WARRANTY

LED3C11 3 LIGHT SET w/ 150' cable & colored lenses (fixed color)

\$ 1,163.00

RGB3C5 COLOR CHANGING w/ 150' cable

\$ 1,853.00

Charles Aquatics, Inc.
6869 Phillips Parkway Drive South Jacksonville, FL 32256
(904) 997-0044 Fax: (904) 807-9158

Fountain Selection – 2hp Kasco 208-240v 1ph – 150ft cable \$ 7,664.00

Optional Premium Nozzle Selection - \$

Light Set Selection – \$

TOTAL -

3. Client agrees to pay 25% deposit and then the balance in full within 10 days of installation. Client agrees to pay 1.5% of unpaid sum(s) after 30 days from installation. This quote is valid for 60 days.



Representative of Charles Aquatics, Inc. 10-24-23
Date

Customer Signature Date

J SERIES PREMIUM NOZZLES

NEW FOR 3/4 & 1HP UNITS!

Premium Nozzles are now available for all J Series units and provide crisp and dramatic patterns. These Nozzles are purchased separately and have easy twist-and-lock installation.

PATTERN	3/4HP - NEW!	1HP - NEW!	2HP	3HP	5HP	7-1/2HP
Mighty Oak	10 x 24	13 x 34	14.5 x 40	19.5 x 51	24.5 x 58	27 x 60
Magnolia	9 x 29	11.5 x 37	13.5 x 44	18 x 60	23.5 x 75	26 x 80
Mahogany	11.5 x 28	14 x 34	16 x 40	21 x 58	28 x 64	29 x 72
Madrone	11.5 x 28	14 x 35	15 x 43	20 x 59	24 x 70	26 x 75
Palm	-	-	12 x 26	16 x 36	20.5 x 40	22 x 42

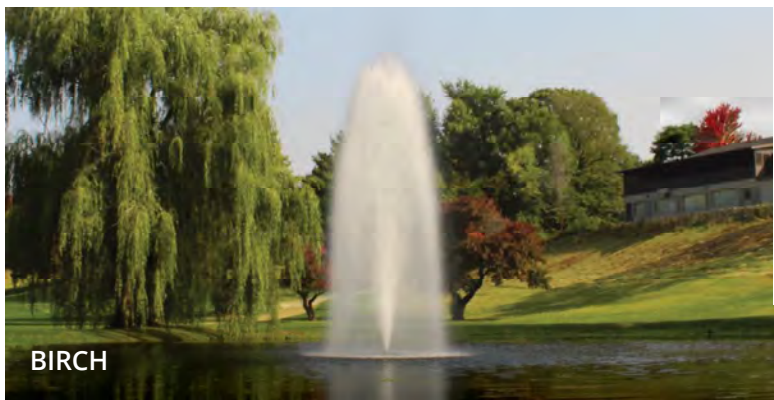
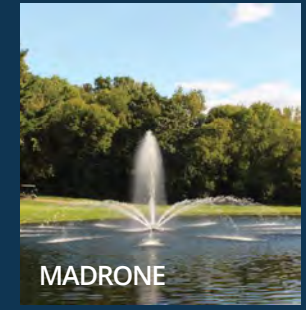

Kasco® FOUNTAINS

*New 2HP J Series Fountain with
New Mahogany Premium Nozzle*

NEW

REDESIGNED J SERIES FOR IMPROVED
PERFORMANCE & PATTERN DEFINITION

1-PIECE TAPERED FLOATS FOR
EASIER ASSEMBLY & IMPROVED LOOK

WHERE BEAUTY MEETS PERFORMANCE

Enhance the aesthetics and improve the health of your body of water with Kasco Fountains. All fountains deliver reliable and efficient performance, and feature marine-grade stainless steel components for protection in harsh environments such as salt water. Explore the multiple pattern options in our J Series line and aerating power of the VFX fountain.

kascomarine.com // 715-262-4488 // sales@kascomarine.com

NEW

Redesigned 2, 3, 5 and 7-1/2HP J Series Fountains

- Better performance and flow without increased amp draw
- Increased flow for dramatically cleaner and defined patterns
- New Balsam 3-Tier pattern
- New Mighty Oak premium pattern
- 1-piece tapered float for easier assembly and improved look at the surface
- Twist and lock nozzles for easy pattern changes
- Snap-on light clips for easy light fixture installations (purchased separately)

J SERIES FOUNTAINS

Kasco J Series Fountains offer dramatic, aesthetically pleasing displays at the best value on the market. Designed with both beauty and function in mind, each package includes 5 twist-and-lock nozzles - **at no extra charge** - allowing you to choose from attention demanding geysers to elegant 3-tier displays.

- Available as 3/4, 1, 2, 3, 5 and 7-1/2HP units, 120V and 208-240V, and single and three phase options
- Package includes unit, float, mooring ropes, power cord, nozzles and control panel with human-rated GFCI protection
- Complete packages are ETL approved to UL and CSA standards
- Operates in as little as 15-30 in. of water, depending on HP
- 2 year warranty on 3/4HP and 1HP units
- 3 year warranty on 2HP units (optional 5 year extended warranty available)
- 5 year warranty on 3, 5 and 7-1/2HP units

New 1-Piece Float on 3HP J Series



MODEL DETAILS	UNIT SIZE (HP)											
	3/4HP		1HP		2HP		3HP		5HP		7-1/2HP	
Model	3400JF	3400HJF	4400JF	4400HJF	8400JF	2.3JF	3.1JF	3.3JF	5.1JF	5.3JF	7.3JF	
Voltage	120	208-240	120	208-240	208-240		208-240		208-240		208-240	
Phase	1	1	1	1	1	3	1	3	1	3	3	
Amperage	6.7	3.3	10.7	5.3	10	7.5	13.4	10.3	20	16	20	
PATTERNS	DISPLAY DIMENSIONS (FT.)											
	H	W	H	W	H	W	H	W	H	W	H	W
Willow	6.5	21	9	31	-	-	-	-	-	-	-	-
Sequoia	13	8	18	11	-	-	-	-	-	-	-	-
Cypress	7	17	9	28	-	-	-	-	-	-	-	-
Linden	9	29	12	31	15.5	38	20.5	38	24.5	46	26	46
Birch	7	5	11	8	11	10	16	12	24	14	26	16
NEW: BALSAM	-	-	-	-	14	32	19	34	18	34	21	36
Spruce	-	-	-	-	21	10	26	12	31	12	34	12
Redwood	-	-	-	-	22	6	27	6	32	6	36	8

Product Notes:

1. Cords are in 50 ft. increments up to 200 ft. on both 120V and 208-240V.
2. 208-240V units also offer 250 ft., 300 ft., 400 ft., and 500 ft. options.
3. 50 ft. power cord not available for 5 and 7-1/2HP units



NEW**BALSAM - 3HP****NEW****REDWOOD - 3HP****NEW****LINDEN - 3HP****NEW****SPRUCE - 5HP****WILLOW - 1HP****CYPRESS - 3/4HP****SEQUOIA - 1HP****BIRCH - 2HP****NEW****Redesigned Nozzles & New Mighty Oak Pattern**

J SERIES PREMIUM NOZZLES

Further define your J Series experience with a Premium Nozzle for the 2, 3, 5, and 7-1/2HP units. Redesigned to allow more flow, Kasco's premium patterns provide crisp and distinct streams of water, for a more attractive display. New to the collection is the Mighty Oak pattern featuring 3 tiers with 8 streams in each, creating a beautifully arched cascade. Premium nozzles easily twist and lock into place and are purchased separately.

NEW**MIGHTY OAK****NEW****MAGNOLIA****NEW****MAHOGANY****NEW****PALM**

PATTERNS	DISPLAY DIMENSIONS (FT.)							
	2 HP		3HP		5HP		7-1/2HP	
	H (ft.)	W (ft.)	H (ft.)	W (ft.)	H (ft.)	W (ft.)	H (ft.)	W (ft.)
NEW: MIGHTY OAK	14.5	40	19.5	51	24.5	58	27	60
Magnolia	13.5	44	18	60	23.5	72	26	80
Mahogany	16	40	21	58	28	64	29	72
Palm	12	26	16	36	20.5	40	22	42

NEW

1-Piece tapered float for 2 & 5HP units provides easier installation & improved look.



New 1-Piece Tapered Float on 5HP VFX



VFX SERIES FOUNTAINS

Kasco VFX Series is the choice for those wanting an elegant display but also require superior aeration benefits. These units are efficient and easy to install and operate.

- Available in 1/2, 3/4, 1, 2 and 5HP options, 120V and 208-240V, and single and three phase options
- Includes unit, float, bottom screen, mooring ropes, power cord, and control panel with GFCI protection
- Snap-on light clips for easy light fixture installations (purchased separately)
- Operates in as little as 15 in. of water
- ETL approved to UL and CSA standards
- 2 year warranty on 1/2, 3/4 and 1HP units
- 3 year warranty on 2 and 5HP units (optional 5 year extended warranty available)

HP	PART NUMBER	DISPLAY		VOLT	PHASE	AMPS
		H (FT.)	W (FT.)			
1/2	2400VFX	5	15	120	1	5.6
3/4	3400VFX	5.5	21	120	1	7.3
	208-240			3.7		
1	4400VFX	8	26	120	1	11.3
	4400HVFX			208-240		5.7
2	8400VFX	8	32	208-240	1	11
	2.3VFX				3	7.5
5	5.1VFX	9	34	208-240	1	20
	5.3VFX				3	16

Product Notes:

1. 2 and 5HP available in three phase 460-480V in approved locations. Contact Kasco for details.
2. Cords are in 50 ft. increments up to 200 ft. on both 120V and 208-240V units
3. 208-240V units also offer 250 ft., 300 ft., 400 ft., and 500 ft. options.
4. 50 ft. power cord not available for 5HP units.

FOUNTAIN LIGHTING

Kasco WaterGlow lighting will dramatically illuminate your fountain or aerator throughout the nighttime hours. Available in composite or stainless steel housings and in several color options, these versatile LED lights are a perfect addition to your display. **NEW** Snap-on light clips are now included with 3 and 6 fixture RGB LED and Composite LED kits, making installation even easier. Compatible with all J Series and VFX fountains.



3/4HP J Series Linden Nozzle, RGB LED Lights



2HP J Series Mahogany Premium Nozzle, Composite LED Lights



3HP J Series Redwood Nozzle, Stainless Steel LED Lights

RGB LED

Choose between 9 colors, 3 rhythmic sequences and the addition of music to hand pick the perfect display.

- Colors include: white, cool white, red, green, blue, orange, yellow, cyan and magenta
- 3 fixture kit works best for 1/2 - 1HP units, 6 fixture kits work best for 2 - 3HP units
- 1-piece composite housing features ultra sonic weld around the lens ensuring water-tight operation

Composite LED

These lighting systems feature durable composite housings to shine brilliantly into the evening hours.

- Displays classic white and includes red, green, blue and amber lenses and lens caps
- 3 fixture kits works best for 1/2 - 1HP units, 6 fixture kits work best or 2 - 5HP
- 1-piece composite housing features ultra sonic weld around the lens ensuring water-tight operation

Stainless Steel LED

Featuring a durable, stainless steel enclosure, these lights will ensure an elegant and classic display.

- Displays classic white and includes red, green, blue and amber lenses and lens caps
- 3 fixture kit works best for 1 - 3HP units, 6 fixture kits work best for 3 - 7-1/2HP units
- UL / CSA Listed

EXHIBIT 9



The Lake Doctors, Inc.
Aquatic Management Services

Corporate Offices
3543 State Road 419
Winter Springs, FL 32708
1-800-666-5253
lakes@lakedoctors.com
www.lakedoctors.com

Sales Agreement
AIRMAX POND SERIES

MAS720157

This Agreement, made this _____ day of _____, 20____ is between The Lake Doctors, Inc., a Florida Corporation, hereinafter called "THE LAKE DOCTORS" and

PROPERTY NAME (Community/Business/Individual) _____

MANAGEMENT COMPANY _____

INVOICING ADDRESS _____

CITY _____ STATE _____ ZIP _____ PHONE () _____

EMAIL ADDRESS _____ EMAIL INVOICE: YES OR NO

THIRD PARTY COMPLIANCE/REGISTRATION: YES OR NO THIRD PARTY INVOICING PORTAL: YES OR NO

***If a Third Party Compliance/Registration or an Invoice Portal is required; it is the customer's responsibility to provide the information.*

Hereinafter called "CUSTOMER" PURCHASE ORDER #: _____

The parties hereto agree to follows:

A. THE LAKE DOCTORS agrees to install or supply the following equipment in accordance with the terms and conditions of this Agreement in the following locations(s):

One (1) Airmax PondSeries Fountain for Tamaya – Beach CDD, Jacksonville Florida.

Includes 2hp, 240V, single phase, floating fountain with 3 Display Nozzles and low profile float assembly. Stainless steel, fully sealed, uL approved, stainless-steel motor, pump system and stainless intake. NEMA 3R powder coated control panel with digital timers. Optional: RGBW Color-changing, Energy efficient high output completely sealed lighting with RF Remote. Deposit must be received prior to installation. Note: All fountains require a properly equipped, dedicated electrical circuit to avoid potential hazards and nuisance tripping
***Excludes on shore electrical repair, if needed. 208V or less voltage to motor will affect fountains performance and reliability.**

B. CUSTOMER agrees to pay THE LAKE DOCTORS, its agents or assigns, the following sum for specified equipment:

1.	2hp 240Volt PondSeries Fountain with 150' cable	\$	<u>6,558.00</u>
2.	4 X RGBW Color-changing Light Set with remote & 150' cable	\$	<u>1,820.00</u>
3.	Control Panel, NEMA 3R, powder coated with GFCI Protection and digital timers	\$	<u>INCLUDED</u>
4.	Three (3) year manufacturer warranty on Fountain and LED lighting	\$	<u>INCLUDED</u>
5.	Free Shipping Discount	\$	<u>INCLUDED</u>
6.	Assembly, Delivery & Anchoring fountain*	\$	<u>500.00</u>
7.	7.5% Sales Tax	\$	<u>Exempt</u>
	Total of Services Accepted	\$	<u>8,878.00</u>

\$4,439.00 deposit shall be payable upon execution of this Agreement, the balance shall be payable upon installation plus any taxes, including sales use taxes, fees or charges that are imposed by any governmental body relating to the service provided under this Agreement. **THE LAKE DOCTORS** considers this sale as made in Florida and is not responsible for the payment of any out-of-state (non-Florida) taxes except as required by law.

- C. THE LAKE DOCTORS agrees to sell only products with a demonstrated reliability and quality.
- D. THE LAKE DOCTORS agrees to supply equipment within **thirty (30) business days**, subject to availability, with receipt of this executed Agreement and required advance deposit.
- E. The offer contained herein is withdrawn and this Agreement shall have no further force and effect unless executed and returned by CUSTOMER to THE LAKE DOCTORS on or before **October 20, 2023**.
- F. The terms and conditions form an integral part of this Agreement, and CUSTOMER hereby acknowledges that he has read and is familiar with the contents thereof. Agreement must be returned in its entirety to be considered valid.

THE LAKE DOCTORS, INC.

CUSTOMER

Signed _____ Dated _____

Mark A. Seymour, Sales Manager

Name _____

TERMS AND CONDITIONS

1. Equipment sold by THE LAKE DOCTORS is warranted to be free from defects in materials and workmanship per warranty of the respective equipment manufacturers. For details, see MANUFACTURER'S warranty.

Eco Series

- ½ HP- 3 Years Warranty on Fountain and Control Panel on Manufacturer Materials and Workmanship
- LED and RGBW Light Set- 3 Years Warranty Parts

Pond Series

- 1 HP & 2HP – 3 Years Warranty on Fountain and Control Panel on Manufacturer Material and Workmanship
- LED and RGBW Light Set- 3 Years Warranty Parts

The liability is limited to the repair or replacement of such items deemed by MANUFACTURER to be defective and will not include items damaged by misuse, vandalism, theft, acts of God or other causes. CUSTOMER shall bear the cost of delivering such defective items to THE LAKE DOCTORS or MANUFACTURER for repair. Any repairs, alteration or modifications made by anyone other than an authorized representative of THE LAKE DOCTORS or MANUFACTURER will void the warranty. Warranty work will not be performed or paid for by THE LAKE DOCTORS or MANUFACTURER unless all past due balances are paid in full. No warranty is made or implied regarding the ability of the equipment to control algae, prevent fish kills, control odors or other performance criteria not directly related to proper mechanical function of the equipment.

2. Failure to follow the MANUFACTURER'S required maintenance may void warranty.
3. Items not covered under our warranty will be treated and billed as regular service calls. Examples of non-warranty work include cleaning of light lenses, unclogging of nozzles and filters, valve adjustments, resetting tripped breakers.
4. CUSTOMER shall be responsible for providing proper electrical power and performing electrical hookups. All electrical work shall meet all applicable governmental requirements. Said power shall be supplied to a designated site agreed upon by THE LAKE DOCTORS and CUSTOMER and generally within 30' or less of lake or ponds edge. In all cases, power supplied should be in accordance with Article 680 and other appropriate provisions of the National Electrical Code including the use of ground fault circuit interrupter-type breakers on each submersible equipment circuit above 15 volts between conductors. It shall be CUSTOMER'S responsibility to ensure that proposed equipment to be supplied by THE LAKE DOCTORS meets all other governmental standards, including but not limited to, local electrical codes, building codes, etc. Additionally, CUSTOMER shall be responsible for obtaining any necessary permits.
5. Due to possible electrical shock hazards resulting from improper functioning of defective equipment, THE LAKE DOCTORS strongly advises CUSTOMER and other responsible parties to prohibit swimming and wading in ponds or bodies of water in which electrical equipment has been installed. Posted notice is advised.
6. THE LAKE DOCTORS does not assume any liability whatsoever for damages, losses or conditions arising from improper use or maintenance of equipment installed by THE LAKE DOCTORS or MANUFACTURER. Furthermore, THE LAKE DOCTORS and MANUFACTURER assumes no liability whatsoever for damages, losses or conditions arising from equipment purchased from THE LAKE DOCTORS and improperly installed, used or maintained by CUSTOMER or others.
7. THE LAKE DOCTORS agrees to hold CUSTOMER harmless from any loss, damage or claims arising out of the sole negligence of THE LAKE DOCTORS. However, THE LAKE DOCTORS shall in no event be liable to CUSTOMER, or others, for indirect, special or consequential damages.
8. Neither party shall be responsible in damages, penalties or otherwise for any failure or delay in the performance of any of its obligations hereunder caused by strikes, riots, war, acts of God, accidents, governmental orders and regulations, curtailment or failure to obtain sufficient material, or other force majeure condition (whether or not of the same class or kind as those set forth above) beyond its reasonable control and which, by the exercise of due diligence, it is unable to overcome.
9. THE LAKE DOCTORS shall maintain the following insurance coverage and limits: (a) Workman's Compensation with statutory limits; (b) Automobile Liability; (c) Comprehensive General Liability, including Pollution Liability, Property Damage, Completed Operations and Product Liability. A Certificate of Insurance will be provided upon request. A Certificate of Insurance naming CUSTOMER as "Additional Insured" may be provided at CUSTOMER'S request. CUSTOMER agrees to pay for any additional costs of insurance requirements over and above that provided by THE LAKE DOCTORS.
10. This Agreement is not assignable by CUSTOMER except upon prior written consent by THE LAKE DOCTORS.
11. Termination of Agreement in writing by CUSTOMER after initiation of Agreement will be subject to a 20% restocking fee plus all shipping costs and subject to a charge equal to time and materials expended upon time of cancellation.
12. Quotations are made and orders accepted on a firm price basis provided customer authorizes shipment and delivery within a period of forty-five (45) days after execution of Sales Agreement. Orders shipped after ninety (90) days are subject to prices in effect on date of shipment. All shipments F.O.B. shipping point.
13. Special or custom orders are not returnable for credit. A special or custom order is defined by THE LAKE DOCTORS as any order deviating from, or modified from, standard items, kits or systems. This shall include any component or system custom built to buyer's specifications.
14. This Agreement constitutes the entire agreement of the parties hereto and shall be valid upon acceptance by THE LAKE DOCTORS Corporate Office. No oral or written alterations or modifications of the terms contained herein shall be valid unless made in writing and accepted by an authorized representative of both THE LAKE DOCTORS and CUSTOMER.
15. THE LAKE DOCTORS reserves the right to impose a monthly service charge on past due balances. CUSTOMER agrees to reimburse THE LAKE DOCTORS for all processing fees for registering with third party companies for compliance monitoring services.
16. Should it become necessary for THE LAKE DOCTORS to bring action for collection of monies due and owing under this Agreement, CUSTOMER agrees to pay collection costs, including, but not limited to, reasonable attorneys' fees (including those on appeal) and court costs, and all other expenses incurred by THE LAKE DOCTORS resulting from such collection action.
17. If the scope of work changes after the execution of the Agreement, the Agreement can be cancelled or the customer will assume any additional cost to complete the modified agreement.

AIRMAX POND SERIES 2HP FOUNTAIN WITH CROWN & TRUMPET PATTERN 13'H X 38'W



AIRMAX[®]



FOUNTAIN AERATION

Make Your Pond the Destination



Why Airmax Fountains?

- Largest Most Defined Spray Patterns
- Innovative Low Maintenance Design
- Best In Class Energy Efficiency
- Made in the USA



Tranquility Starts With Airmax

Airmax Fountains Can Ensure Health AND Beauty for Your Pond

Fountain Comparison Chart	EcoSeries	PondSeries	LakeSeries
Horsepower Options			
Minimum Operating Depth	½ HP	½ HP, 1 HP & 2 HP	2 HP, 3 HP & 5 HP
Float Type	24"	36"	36", 48" & 60"
Light Set Options	Drop In	Drop In	ISP Float System
Warranty	2, 4 & 8 Lights	2, 4 & 8 Lights	9 & 12 Lights
	3 Years	3 Years	5 Years



EcoSeries™ Fountain

Bold, Beautiful Patterns & Energy Efficient



PREMIUM DISPLAYS

- Well defined, industry leading spray patterns for strong, stunning displays
- Airmax exclusive quick-change nozzles can be switched out in seconds
- Low-profile, drop-in style, float design keeps the fountain steady and balanced in the water
- Includes 3 spray patterns. Additional premium nozzles available

ENGINEERED TO LAST

- Asynchronous energy efficient motor is water cooled, powerful and built to last
- Low maintenance: No oil, seals or bearings to change
- Stainless-steel wrapped motor lead protects against animal chewing
- Power cord strain relief keeps connections secure
- Ground-fault circuit interrupter (GFCI) protection

EFFICIENT DESIGN

- Bottom-draw design pulls water from deeper in the pond for better aeration
- More performance with lower operating cost than comparable fountains
- High-quality control panels, with standard dual digital timers to accommodate fountain and lights
- Under water quick disconnect, standard with all cords
- 3-year warranty on motor and components

ADDITIONAL OPTIONS

- Optional RGBW light sets bring your fountain to life at night
- Stainless-steel or Polyflex power cord protection



Top Down View of Float and Quick-Change Nozzle



Bottom-Draw Pulls Water From Deeper in the Pond

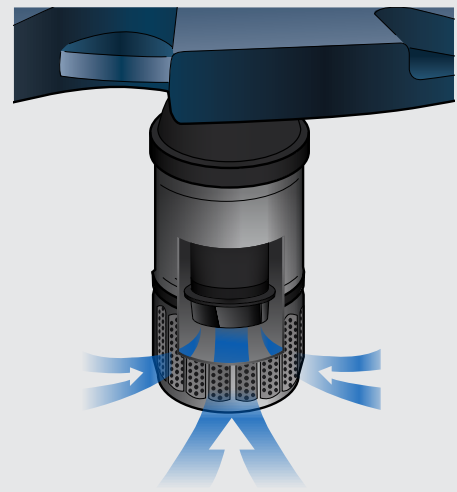

Airmax Control Panel Comes Standard with Dual Digital Timers for Both Fountain & Lights





**Crown & Trumpet
INCLUDED SPRAY PATTERN**

EcoSeries Pattern Dimensions		
HP	Trumpet	Crown
1/2 HP	8' H x 4' W	4' H x 32' W

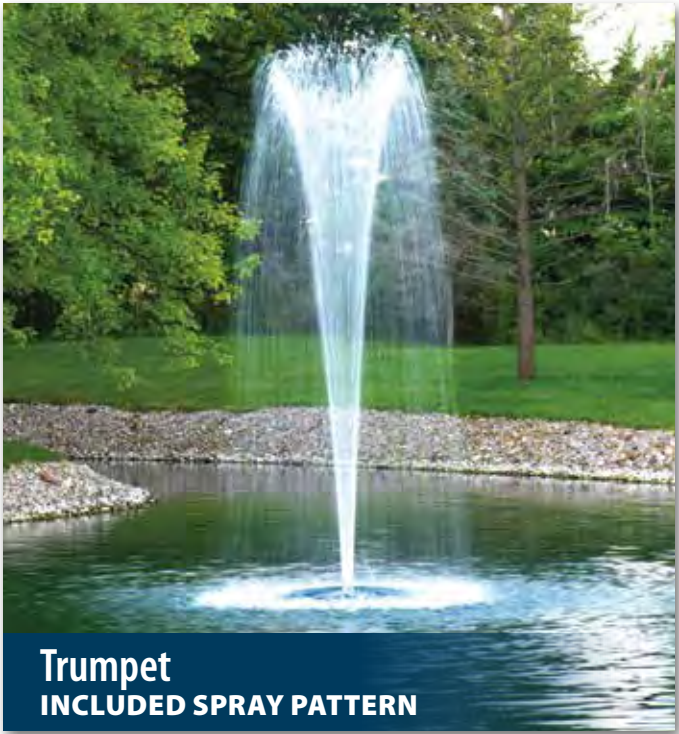

**Trumpet
INCLUDED SPRAY PATTERN**

EcoSeries Pattern Dimensions	
HP	H x W
1/2 HP	14' H x 7' W



**Classic
INCLUDED SPRAY PATTERN**

EcoSeries Pattern Dimensions	
HP	H x W
1/2 HP	6' H x 16' W





Double Arch & Geyser
OPTIONAL SPRAY PATTERN

EcoSeries Pattern Dimensions			
HP	Geyser	1st Tier	2nd Tier
1/2 HP	9' H	7' H x 12' W	5' H x 34' W



Single Arch
OPTIONAL SPRAY PATTERN

EcoSeries Pattern Dimensions	
HP	H x W
1/2 HP	8' H x 16' W





Double Arch OPTIONAL SPRAY PATTERN

EcoSeries Pattern Dimensions

HP	1st Tier	2nd Tier
1/2 HP	10' H x 16' W	5' H x 38' W



Blossom (Crown & Arch) OPTIONAL SPRAY PATTERN

EcoSeries Pattern Dimensions

HP	1st Tier	2nd Tier
1/2 HP	4' H x 6.5' W	1.5' H x 11' W





PondSeries® Fountain

Superior Performance, Stunning Displays

PREMIUM DISPLAYS

- Crisp spray patterns provide a beautiful aerating display
- Airmax exclusive quick-change nozzles can be switched out in seconds
- Low-profile, drop-in style, float design keeps the fountain steady and balanced in water
- Includes 3 spray patterns. Additional premium nozzles available

LONG-LASTING DURABILITY

- Stainless-steel Continuous Duty Water Cooled Motor is maintenance-free, providing long-lasting performance without annual maintenance costs
- Independent Pump System for longevity and protection against wear to motor, shaft and seals
- Integrated Cooling Shroud for maximum motor life and efficiency
- Stainless-steel motor lead protects against damage from debris or animal chewing
- Power cord strain relief keeps connections secure
- Oversized modular intake screen prevents clogging

SUPERIOR PERFORMANCE

- Bottom-draw design pulls water from deeper in the pond for better aeration
- More performance with lower operating cost than comparable fountains
- High-quality control panels, with standard dual digital timers to accommodate fountain and lights
- 3-year warranty on unit and control panel

ADDITIONAL OPTIONS

- Optional RGBW light sets bring your fountain to life at night
- Stainless-steel or Polyflex power cord protection



Top Down View of Float and Quick-Change Nozzle



Bottom-Draw Design Pulls Water From Deeper in the Pond and Through the Integrated Cooling Shroud

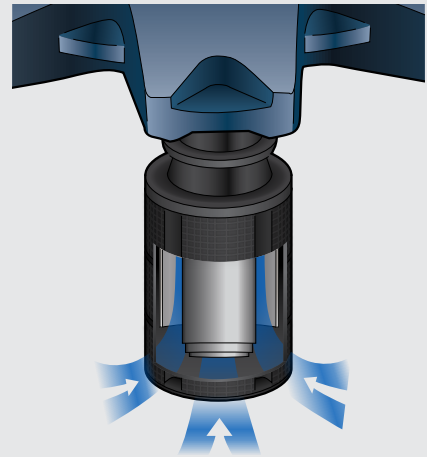

Airmax Control Panel Comes Standard with Dual Digital Timers for Both Fountain & Lights





**Crown & Trumpet
INCLUDED SPRAY PATTERN**

PondSeries Pattern Dimensions		
HP	Trumpet	Crown
1/2 HP	8' H x 6' W	4.5' H x 32' W
1 HP	11' H x 6' W	4.5' H x 32' W
2 HP	13' H x 8' W	6.5' H x 38' W



**Trumpet
INCLUDED SPRAY PATTERN**

PondSeries Pattern Dimensions	
HP	H x W
1/2 HP	12.5' H x 5' W
1 HP	16' H x 6' W
2 HP	17' H x 7' W



**Classic
INCLUDED SPRAY PATTERN**

PondSeries Pattern Dimensions	
HP	H x W
1/2 HP	5.5' H x 13' W
1 HP	9.5' H x 23' W
2 HP	14' H x 28' W





Double Arch & Geyser
OPTIONAL SPRAY PATTERN

PondSeries Pattern Dimensions			
HP	Geyser	1st Tier	2nd Tier
1/2 HP	9' H	6' H x 7' W	4' H x 28' W
1 HP	8.5' H	5.5' H x 13' W	4' H x 30' W
2 HP	9.5' H	6' H x 15' W	4' H x 32' W



Single Arch
OPTIONAL SPRAY PATTERN

PondSeries Pattern Dimensions	
HP	H x W
1/2 HP	9' H x 14' W
1 HP	8' H x 22' W
2 HP	9' H x 24' W





Double Arch OPTIONAL SPRAY PATTERN

PondSeries Pattern Dimensions

HP	1st Tier	2nd Tier
1/2 HP	8' H x 8' W	4.5' H x 28' W
1 HP	9' H x 10' W	5' H x 34' W
2 HP	10' H x 10' W	5.5' H x 36' W



Blossom (Crown & Arch) OPTIONAL SPRAY PATTERN

PondSeries Pattern Dimensions

HP	1st Tier	2nd Tier
1/2 HP	5' H x 7' W	2' H x 13' W
1 HP	6.5' H x 10' W	2' H x 19' W
2 HP	8.5' H x 10' W	2.5' H x 22' W



LakeSeries® Fountain

Unrivalled Performance, Striking Displays



PREMIUM DISPLAYS

- Large high-volume laminar spray patterns
- Airmax exclusive quick-change nozzles can be switched out in seconds
- Industry Exclusive ISP Float System provides maximum stability allowing for larger, higher volume patterns while eliminating all float noise associated with falling water
- Multiple spray pattern nozzles available

INNOVATIVE DESIGN

- Stainless-steel Continuous Duty Water Cooled Motor is maintenance-free, providing long-lasting performance without annual maintenance costs
- Independent Pump System for longevity and protection against wear to motor, shaft and seals
- Integrated Cooling Shroud for maximum motor life and cooling
- Stainless-steel motor lead protects against damage from debris or animal chewing
- Power cord strain relief keeps connections secure
- Oversized modular intake screen prevents clogging

ENGINEERED EXCELLENCE

- Bottom-draw design pulls water from deeper in the pond for better aeration
- Greater performance with lower operating cost than comparable fountains
- High-quality control panels, with standard dual digital timers to accommodate fountain and lights
- 5-year warranty on unit and control panel

ADDITIONAL OPTIONS

- Optional RGBW light sets bring your fountain to life at night
- Stainless-steel or Polyflex power cord protection



Industry Exclusive ISP Float System

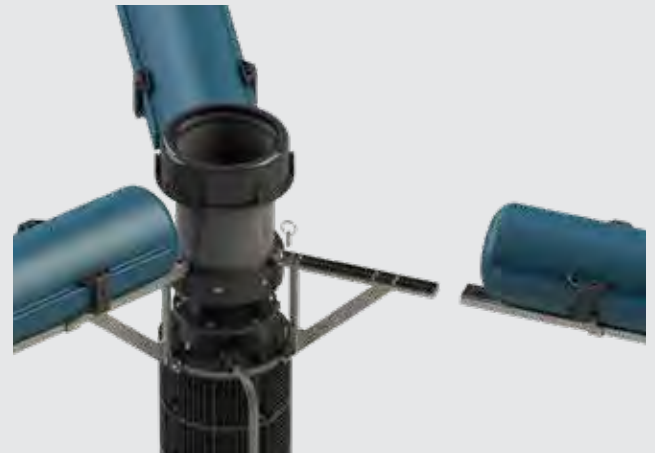

Bottom-Draw Design Pulls Water From Deeper in the Pond and Through the Integrated Cooling Shroud

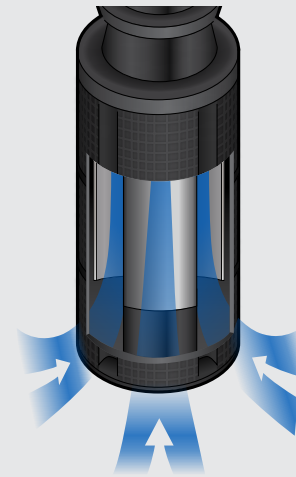

Airmax 230v Control Panel Comes Standard with Dual Digital Timers for Both Fountain & Lights





Crown & Trumpet
OPTIONAL SPRAY PATTERN

LakeSeries Pattern Dimensions		
HP	Trumpet	Crown
2 HP	14' H x 10' W	6' H x 46' W
3 HP	15' H x 10' W	8' H x 50' W
5 HP	24' H x 8' W	12' H x 56' W



Trumpet
OPTIONAL SPRAY PATTERN

LakeSeries Pattern Dimensions	
HP	H x W
2 HP	20' H x 9' W
3 HP	23' H x 10' W
5 HP	30' H x 10' W

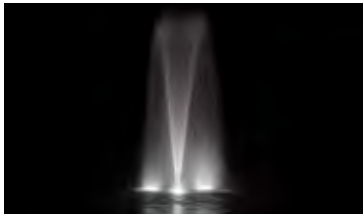

Classic
OPTIONAL SPRAY PATTERN

LakeSeries Pattern Dimensions	
HP	H x W
2 HP	11' H x 30' W
3 HP	13' H x 30' W
5 HP	16' H x 35' W

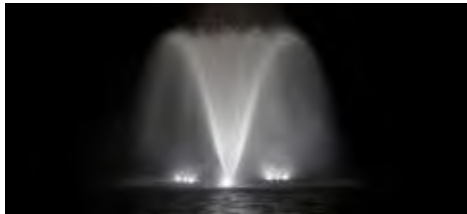



Single Arch
OPTIONAL SPRAY PATTERN

LakeSeries Pattern Dimensions	
HP	H x W
2 HP	13' H x 30' W
3 HP	15' H x 40' W
5 HP	20' H x 40' W

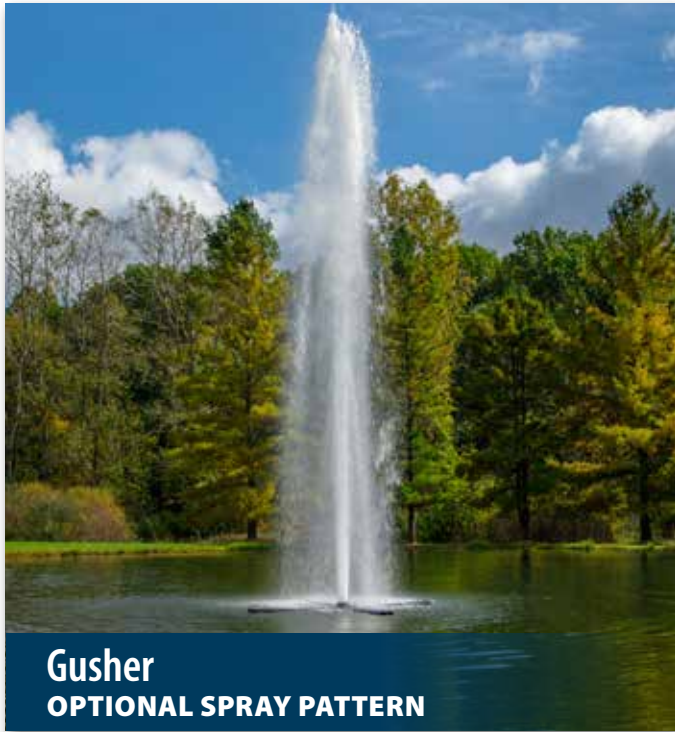

Gusher
OPTIONAL SPRAY PATTERN

LakeSeries Pattern Dimensions	
HP	Height
2 HP	21' H
3 HP	28' H
5 HP	35' H



Blossom (Crown & Arch)
OPTIONAL SPRAY PATTERN

LakeSeries Pattern Dimensions		
HP	1st Tier	2nd Tier
2 HP	14' H x 16' W	2.5'h x 20' W
3 HP	16' H x 11' W	3' H x 24' W
5 HP	17' H x 17' W	5' H x 30' W





Double Arch
OPTIONAL SPRAY PATTERN

LakeSeries Pattern Dimensions		
HP	1st Tier	2nd Tier
2 HP	13' H x 16' W	6' H x 46' W
3 HP	16' H x 12' W	8' H x 50' W
5 HP	20' H x 20' W	10' H x 60' W

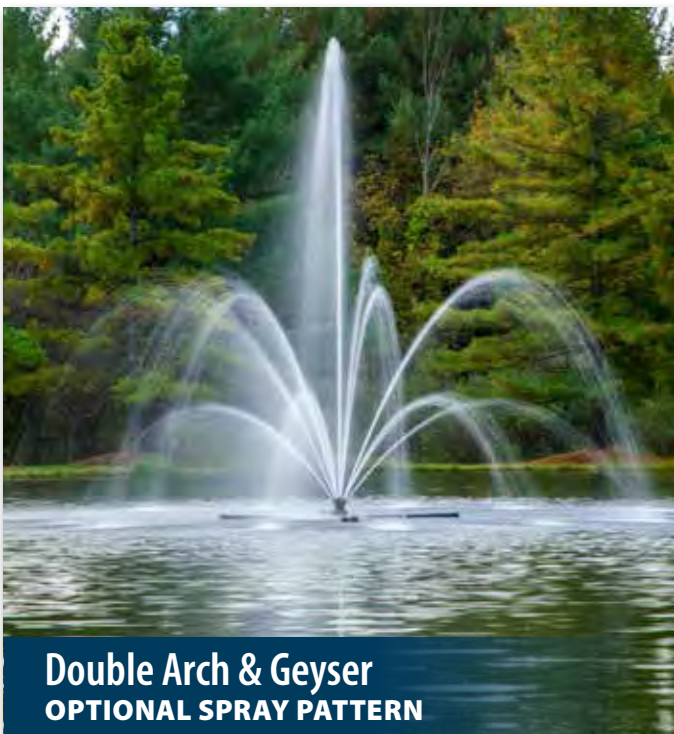

Double Arch & Geyser
OPTIONAL SPRAY PATTERN

LakeSeries Pattern Dimensions			
HP	Geyser	1st Tier	2nd Tier
2 HP	13' H	7' H x 20' W	4' H x 30' W
3 HP	15' H	9' H x 20' W	6' H x 40' W
5 HP	20' H	11' H x 22' W	7' H x 48' W

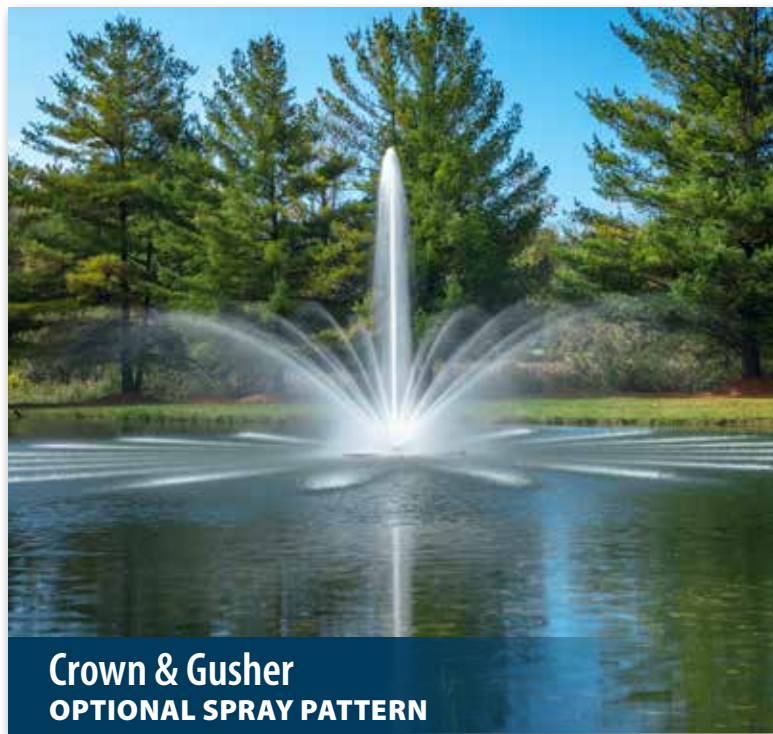

Crown & Gusher
OPTIONAL SPRAY PATTERN

LakeSeries Pattern Dimensions		
HP	Gusher	Crown
2 HP	15' H	8' H x 52' W
3 HP	16' H	11' H x 50' W
5 HP	22' H	13' H x 60' W



Airmax Warranty Information

- EcoSeries & PondSeries Fountain - 3 Years
- LakeSeries Fountain - 5 Years
- Airmax RGBW Light Sets - 3 Years



Spray Pattern Dimensions



	Crown & Trumpet		Trumpet	Classic	Gusher	Crown & Gusher	
EcoSeries	Trumpet	Crown	H x W	H x W	H x W	Gusher	Crown
1/2 HP	8' H x 4' W	4' H x 32' W	14' H x 7' W	6' H x 16' W	N/A	N/A	N/A
PondSeries	Trumpet	Crown	H x W	H x W	H x W	Gusher	Crown
1/2 HP	8' H x 6' W	4.5' H x 32' W	12.5' H x 5' W	5.5' H x 13' W	N/A	N/A	N/A
1 HP	11' H x 6' W	4.5' H x 32' W	16' H x 6' W	9.5' H x 23' W	N/A	N/A	N/A
2 HP	13' H x 8' W	6.5' H x 38' W	17' H x 7' W	14' H x 28' W	N/A	N/A	N/A
LakeSeries	Trumpet	Crown	H x W	H x W	H x W	Gusher	Crown
2 HP	14' H x 10' W	6' H x 46' W	20' H x 9' W	11' H x 30' W	21' H	15' H	8' H x 52' W
3 HP	15' H x 10' W	8' H x 50' W	23' H x 10' W	13' H x 30' W	28' H	16' H	11' H x 50' W
5 HP	24' H x 8' W	12' H x 56' W	30' H x 10' W	16' H x 35' W	35' H	22' H	13' H x 60' W

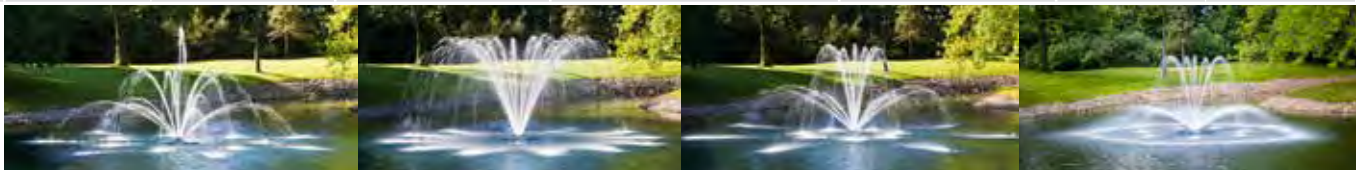

	Double Arch & Geyser			Single Arch	Double Arch		Blossom (Crown & Arch)	
EcoSeries	Geyser	1st Tier	2nd Tier	H x W	1st Tier	2nd Tier	1st Tier	2nd Tier
1/2 HP	9' H	7' H x 12' W	5' H x 34' W	8' H x 16' W	10' H x 16' W	5' H x 38' W	4' H x 6.5' W	1.5' H x 11' W
PondSeries	Geyser	1st Tier	2nd Tier	H x W	1st Tier	2nd Tier	1st Tier	2nd Tier
1/2 HP	9' H	6' H x 7' W	4' H x 28' W	9' H x 14' W	8' H x 8' W	4.5' H x 28' W	5' H x 7' W	2' H 13' W
1 HP	8.5' H	5.5' H x 13' W	4' H x 30' W	8' H x 22' W	9' H x 10' W	5' H x 34' W	6.5' H x 10' W	2' H x 19' W
2 HP	9.5' H	6' H x 15' W	4' H x 32' W	9' H x 24' W	10' H x 10' W	5.5' H x 36' W	8.5' H x 10' W	2.5' H x 22' W
LakeSeries	Geyser	1st Tier	2nd Tier	H x W	1st Tier	2nd Tier	1st Tier	2nd Tier
2 HP	13' H	7' H x 20' W	4' H x 30' W	13' H x 30' W	13' H x 16' W	6' H x 46' W	14' H x 16' W	2.5' H x 20' W
3 HP	15' H	9' H x 20' W	6' H x 40' W	15' H x 40' W	16' H x 12' W	8' H x 50' W	16' H x 11' W	3' H x 24' W
5 HP	20' H	11' H x 22' W	7' H x 48' W	20' H x 40' W	20' H x 20' W	10' H x 60' W	17' H x 17' W	5' H x 30' W



Fountain & Diffused Aeration

The Perfect Pairing for Ideal Pond Health & Beauty

LET A CERTIFIED AIRMAX INSTALLER DESIGN THE RIGHT SYSTEM FOR YOUR POND OR LAKE!

Fountains offer aesthetic beauty, relaxing sound, and great surface aeration. If you're looking to maximize the appearance and overall health of your pond or lake, consider supplementing your fountain with diffused aeration. Bottom-diffused aeration reduces muck, improves water clarity, and increases oxygen levels for a healthier overall ecosystem.

Our certified Airmax professionals will help you select the right fountain and aeration system for your unique needs.

HERE IS HOW TO GET YOUR LAYOUT:

Visit www.airmaxeco.com/airmax-assist and complete a short survey. Airmax will run this information along with input from your local Certified Installer through the Airmax Assist proprietary software to create a complete pond profile, detailed aeration placement map and a management plan.

Customer Information

Customer Number:	10532	Site Address:	123 Main St.
Customer Name:	John Smith	Date Created:	10/20/2018
Site Name:	John's Pond	Design Tech:	Scott Fox

Recommended Airmax® Aeration System(s)

Aerator Type	Direct Burial Size (inch)	Direct Burial Length (feet)	Weighted Aeration Size (inch)	Weighted Aeration Length (feet)
PS20-4	5/8	120	3/8	30
PS20-4	5/8	150	3/8	38
PS20-1	1 1/4	23	3/8	75

System Specifications

Surface Acres:	.33
Average Depth:	7
Acres Feet:	2.31
Deepend Diffuser Depth (feet):	15
Perimeter (feet):	490

Results for Aeration

Total Volume (gallons):	500,000
Calculated Site Turnover (24hrs):	20.02
Estimated System PPG:	158

Pond Information

Site Address: 123 Main St. | Site Created: 10/20/2018 | Design Tech: Scott Fox

Customer Name: John Smith | Customer Name: John Smith | Site Name: John's Pond

AIRMAX

This system was developed, designed and verified using AirmaxAssist® Software. To learn more about Airmax® Aeration Systems, please visit www.airmaxeco.com

1 of 3



Shallow Water Series® Aeration Systems
Single Systems Aerate up to 1/2 Acre



PondSeries® Aeration Systems
Single Systems Aerate up to 6 Acres



LakeSeries® Aeration Systems
Single Systems Aerate up to 12 Acres



LakeSeries 3 HP Crown & Gusher

Optional Fountain Accessories

Protect Your Investment & Make Installation a Breeze

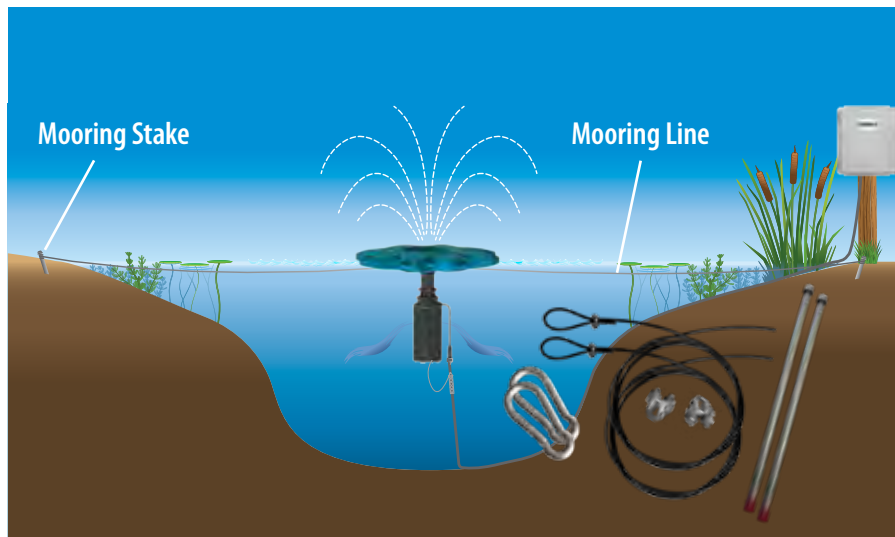

Mooring Kit

Fountains often move around with the wind and waves. You can secure your fountain by anchoring it using a Mooring Kit.

Each kit includes all necessary mooring supplies: two stakes, two carabiners, four cable clamps, and your choice of 150', 250' or 500' of black vinyl coated galvanized cable (mooring line). Works with all Airmax Fountain series.



Power Cord Protection

Nuisance pond wildlife such as beavers and muskrats are notorious for chewing wiring. Protect your fountain investment by upgrading your cord protection.

Power cords can be wrapped with our durable PolyFlex protective sheathing, or if you are looking for something more substantial, we highly recommend the stainless-steel option for the ultimate power cord protection.



Protect Your Investment With Upgraded Cord Protection



RGBW Color-Changing Lights

RF Remote with 200' Range



- Energy Efficient High Output LED, 120 Volt
- Completely Sealed, Adjustable Above Waterline Design for Low Maintenance
- All Light Sets Include Stainless-Steel Braiding on Power Lead and Between Light Fixtures
- Power Cords Come Standard with Strain Relief and Underwater Disconnect; 100' - 600' Lengths. Also Available with Stainless-Steel and Polyflex Protected Cords
- RF Remote with 200' Range is Included with All RGBW Color-Changing Light Sets
- Compatible With All Manufacturers' Fountains
- EcoSeries & PondSeries available in 2, 4 & 8 LED Light Sets
- LakeSeries Available in 9 & 12 LED Light Sets
- 3-Year Warranty



Sealed Adjustable Light Fixtures with an Easy Snap-on Design

Adjustable Color Temperature

Broader range of Kelvin allows for changes from cool white to warm white, and vibrant colors to pastels.



Warm White



Cool White



Pastel Blue



Vibrant Blue



Pastel Green



Vibrant Green



RGBW Lights 2700-6500K



Bring Your Fountain to Life

You Can Enjoy Your Fountain at All Hours – Even at Night!



SEE NIGHTTIME DISPLAYS IN ACTION
WATCH THE VIDEOS @ [AIRMAXECO.COM](https://airmaxeco.com)

Distributed By:

AIRMAX[®]
airmaxeco.com | 866.424.7629

EXHIBIT 10

ESTIMATE

Lucas Tree Service Inc
PO BOX 50814
JACKSONVILLE BEACH, FL 32240

treeservicelucas@gmail.com
+1 (904) 241-3533
<http://Lucastreeservice.com>

Beach CDD

Bill to
Beach CDD

Ship to
Beach CDD

Estimate details

Estimate no.: 7161
Estimate date: 10/24/2023

#	Date	Product or service	SKU	Qty	Rate	Amount
1.		2615 Ostia Cir				\$0.00
2.		Services Drop dead pine tree				\$650.00
					Total	\$650.00

Note to customer

Thank You for calling Lucas Tree Service!



EXHIBIT 11

October 26, 2023

Work Order No. 22-164.04

File No. 128H-20.04A

CDD Transfer Parcel 1

A portion of Section 29, Township 2 South, Range 28 East, Duval County, Florida, being the same lands as described and recorded in Official Records Book 17069, page 35, of the current Public Records of said county, being more particularly described as follows:

For a Point of Reference, commence at the Southwesterly corner of Coachman Meadows Unit One, as recorded in Plat Book 54, pages 89, 89A through 89B, of said current Public Records, said corner lying on the Northerly right of way line of Alden Road, a variable width right of way as presently established; thence Westerly along said Northerly right of way the following 3 courses: Course 1, thence South $89^{\circ}54'16''$ West, 600.00 feet; Course 2, thence North $00^{\circ}23'53''$ West, 20.00 feet; Course 3, thence South $87^{\circ}53'01''$ West, 600.00 feet to the Southwesterly corner of those lands described and recorded in Official Records Book 13034, page 270, of said current Public Records and the Point of Beginning.

From said Point of Beginning, thence continue South $87^{\circ}53'01''$ West, along said Northerly right of way line, 348.32 feet to the Southwesterly corner of those lands described and recorded in said Official Records Book 17069, page 35, said corner lying on the Westerly line of that certain 45 foot Lateral Ditch right of way, as depicted on Alden Trace Unit Three, recorded in Plat Book 42, pages 60, 60A through 60C, of said current Public Records; thence North $02^{\circ}21'54''$ West, departing said Northerly right of way line and along said Westerly line, 42.52 feet to an angle point; thence North $14^{\circ}00'55''$ East, continuing along said Westerly line, along the Easterly line of said Alden Tract Unit Three and along its Northerly prolongation, 1483.58 feet to a point lying on the Southerly right of way line of that certain 40 foot Drainage Right of Way, as described and recorded in Official Records Volume 824, page 384, of said current Public Records; thence North $89^{\circ}55'24''$ East, along said Southerly right of way line, 50.07 feet to the Northwesterly corner of those lands described and recorded in said Official Records Book 13034, page 270; thence South $02^{\circ}19'14''$ West, departing said Southerly right of way line and along the Westerly line of last said lands, 1470.31 feet to the Point of Beginning.

Containing 6.92 acres, more or less.

SKETCH TO ACCOMPANY DESCRIPTION OF

A PORTION OF SECTION 29, TOWNSHIP 2 SOUTH, RANGE 28 EAST, DUVAL COUNTY, FLORIDA, BEING THE SAME LANDS AS DESCRIBED AND RECORDED IN OFFICIAL RECORDS BOOK 17069, PAGE 35, OF THE CURRENT PUBLIC RECORDS OF SAID COUNTY, BEING MORE PARTICULARLY DESCRIBED IN SEPARATE ATTACHMENT.

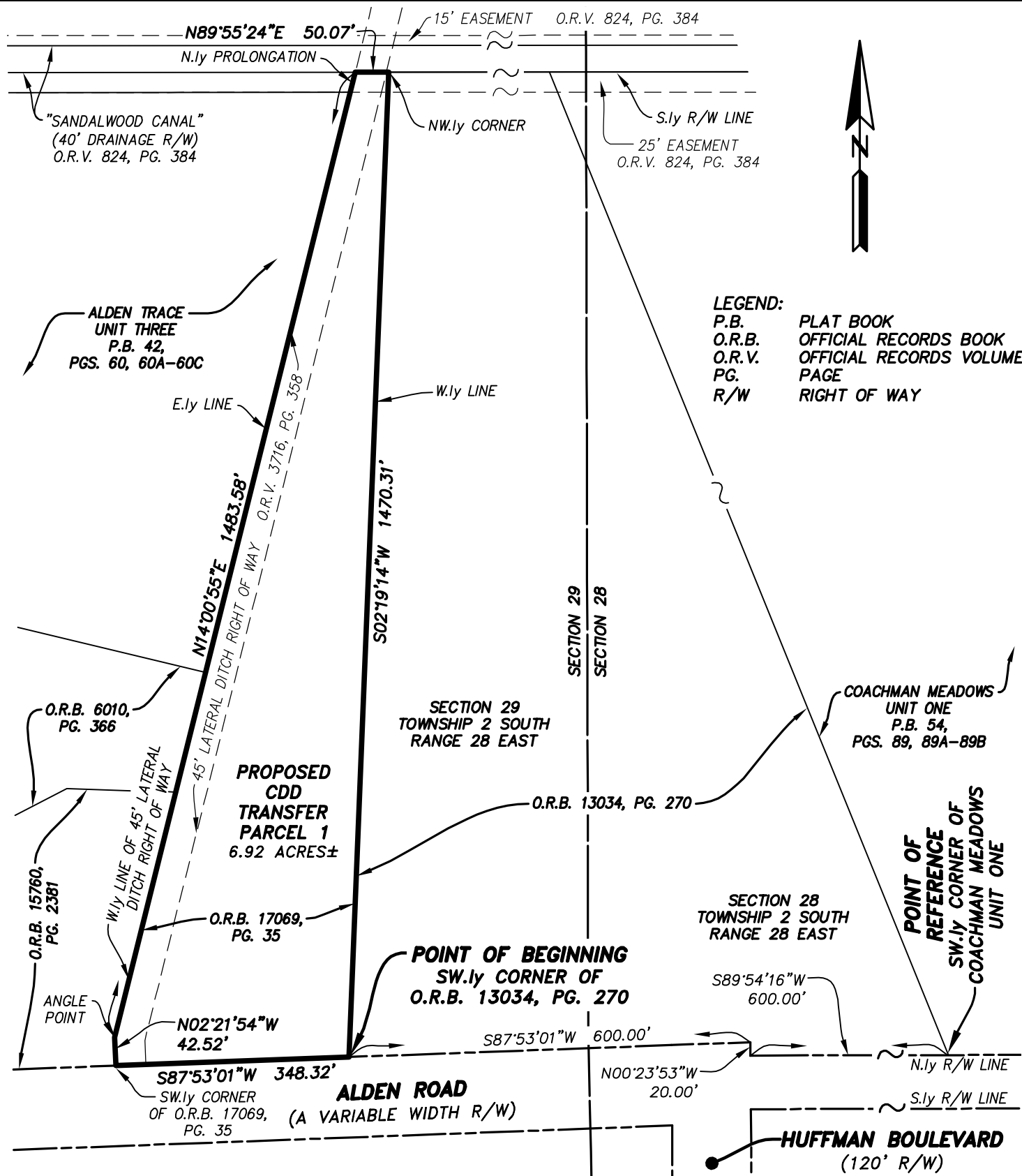

ETM

Surveying & Mapping, Inc.
 VISION • EXPERIENCE • RESULTS

THIS ITEM HAS BEEN ELECTRONICALLY SIGNED AND SEALED USING A DIGITAL SIGNATURE. PRINTED COPIES OF THIS DOCUMENT ARE NOT CONSIDERED SIGNED AND SEALED AND THE SIGNATURE MUST BE VERIFIED ON ANY ELECTRONIC COPIES.

14775 Old St. Augustine Road, Jacksonville, FL 32258
 Tel: (904) 642-8550 Fax: (904) 642-4165
 Certificate of Authorization No.: LB 3624

SCALE: 1"=200'
 DATE: OCTOBER 26, 2023

BOB L. PITTMAN
 PROFESSIONAL SURVEYOR AND MAPPER
 STATE OF FLORIDA PSM No. 4827

EXHIBIT 12

October 26, 2023

Work Order No. 22-164.04
File No. 128H-20.04B

CDD Transfer Parcel 2

A portion of Section 29, Township 2 South, Range 28 East, Duval County, Florida, being the same lands as described and recorded in Official Records Book 17069, page 35, of the current Public Records of said county, being more particularly described as follows:

For a Point of Beginning, commence at the Northeasterly corner of Alden Trace Unit Three, as recorded in Plat Book 43, pages 60, 60A through 60C, of said current Public Records; thence South $89^{\circ}57'25''$ West, along the Northerly line of said Alden Trace Unit Three, along the Northerly line of Alden Trace Unit Two, as recorded in Plat Book 41, pages 36 and 36A, and along the Northerly line of Alden Trace Unit One, as recorded in Plat Book 39, pages 44 and 44A, both of said current Public Records, 2241.89 feet to a point lying on the Easterly line of those lands described and recorded in Official Records Book 15580, page 2112, of said current Public Records; thence North $13^{\circ}06'03''$ West, departing said Northerly line and along said Easterly line, 25.66 feet to a point lying on the Southerly right of way line of that certain 40 foot Drainage right of way, as depicted on said Alden Trace Units One, Two and Three; thence North $89^{\circ}57'25''$ East, departing said Easterly line and along said Southerly right of way line, 2253.96 feet to a point lying on the Northerly prolongation of the Easterly line of said Alden Trace Unit Three; thence South $14^{\circ}02'56''$ West, departing said Southerly right of way line and along said Northerly prolongation, 25.78 feet to the Point of Beginning.

Containing 1.29 acres, more or less.

**SKETCH TO ACCOMPANY DESCRIPTION OF
A PORTION OF SECTION 29, TOWNSHIP 2 SOUTH, RANGE 28 EAST,
DUVAL COUNTY, FLORIDA, BEING THE SAME LANDS AS DESCRIBED
AND RECORDED IN OFFICIAL RECORDS BOOK 17069, PAGE 35,
OF THE CURRENT PUBLIC RECORDS OF SAID COUNTY,
BEING MORE PARTICULARLY DESCRIBED IN SEPARATE ATTACHMENT.**

LINE TABLE		
LINE	BEARING	LENGTH
L1	N13°06'03"W	25.66'
L2	S14°02'56"W	25.78'

LEGEND:
P.B. PLAT BOOK
O.R.B. OFFICIAL RECORDS BOOK
O.R.V. OFFICIAL RECORDS VOLUME
PG. PAGE
R/W RIGHT OF WAY
L1 TABULATED LINE DATA

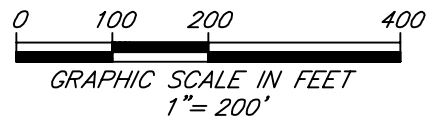
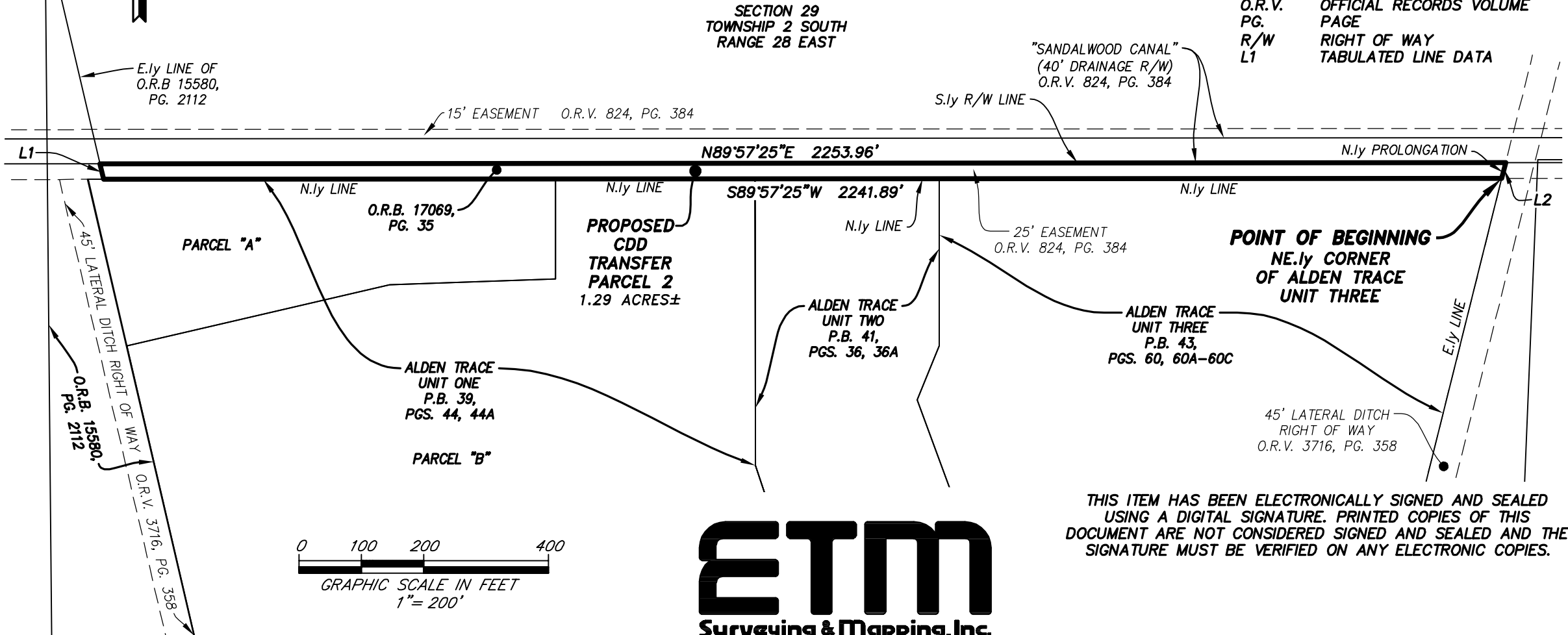

THIS ITEM HAS BEEN ELECTRONICALLY SIGNED AND SEALED USING A DIGITAL SIGNATURE. PRINTED COPIES OF THIS DOCUMENT ARE NOT CONSIDERED SIGNED AND SEALED AND THE SIGNATURE MUST BE VERIFIED ON ANY ELECTRONIC COPIES.

ETM
Surveying & Mapping, Inc.
VISION • EXPERIENCE • RESULTS

14775 Old St. Augustine Road, Jacksonville, FL. 32258
Tel: (904) 642-8550 Fax: (904) 642-4165
Certificate of Authorization No.: LB 3624

SCALE: 1"=200'
DATE: OCTOBER 26, 2023

BOB L. PITTMAN
PROFESSIONAL SURVEYOR AND MAPPER
STATE of FLORIDA PSM No. 4827

GENERAL NOTES:

- 1) THIS IS NOT A SURVEY.
- 2) BEARINGS BASED ON THE NORTHERLY LINE OF ALDEN TRACE UNIT THREE AS BEING SOUTH 89°57'25" WEST.

EXHIBIT 13

October 26, 2023

Work Order No. 22-164.04
File No. 128H-20.04C

CDD Transfer Parcel 3

A portion of Section 28, Township 2 South, Range 28 East, Duval County, Florida, being the same lands as Parcel B, as described and recorded in Official Records Book 16336, page 2390, of the current Public Records of said county, being more particularly described as follows:

For a Point of Beginning, commence at the Northwesterly corner of Richmond Place, as recorded in Plat Book 55, pages 82, 82A through 82B, of said current Public Records; thence South $07^{\circ}56'11''$ East, along the Westerly line of said Richmond Place, 126.19 feet to the Northwesterly corner of Tract "A", as depicted on said Richmond Place; thence South $89^{\circ}55'25''$ West, departing said Westerly line, 998.38 feet to the Northeasterly corner of Tract "A", as depicted on Coachman Meadows Unit Two, recorded in Plat 55, pages 3 and 3A, of said current Public Records; thence North $03^{\circ}03'49''$ East, along the Easterly line of said Coachman Meadows Unit Two, a distance of 125.19 feet to the Northeasterly corner thereof, said corner lying on the Southerly right of way line of that certain 40 foot Drainage right of way, as depicted on said Coachman Meadows Unit Two and said Richmond Place; thence North $89^{\circ}55'25''$ East, departing said Easterly line and along said Southerly right of way line, 974.26 feet to the Point of Beginning.

Containing 2.83 acres, more or less.

**SKETCH TO ACCOMPANY DESCRIPTION OF
A PORTION OF SECTION 28, TOWNSHIP 2 SOUTH, RANGE 28 EAST,
DUVAL COUNTY, FLORIDA, BEING THE SAME LANDS AS PARCEL B,
AS DESCRIBED AND RECORDED IN OFFICIAL RECORDS BOOK 16336,
PAGE 2390, OF THE CURRENT PUBLIC RECORDS OF SAID COUNTY,
BEING MORE PARTICULARLY DESCRIBED IN SEPARATE ATTACHMENT.**

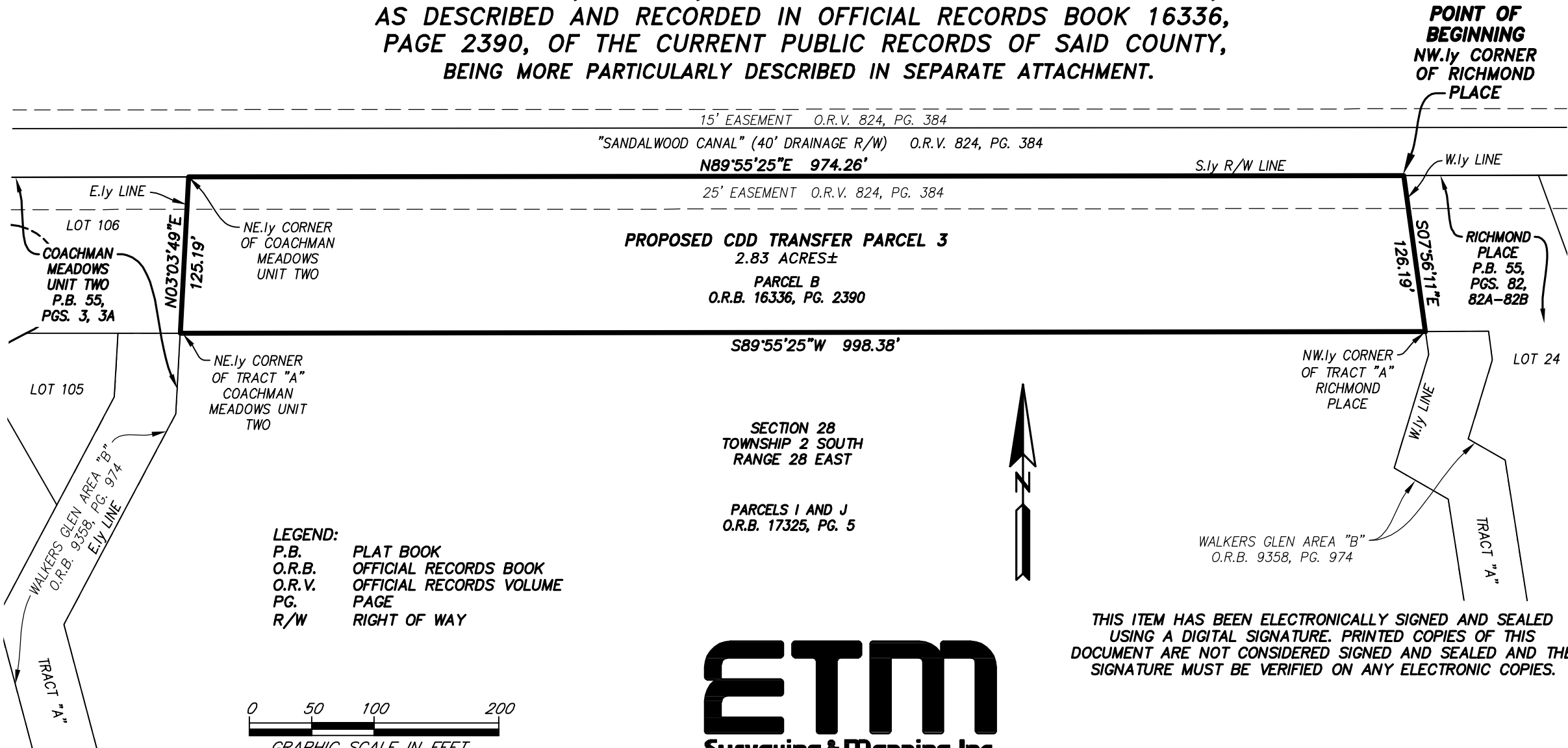

LEGEND:
P.B. PLAT BOOK
O.R.B. OFFICIAL RECORDS BOOK
O.R.V. OFFICIAL RECORDS VOLUME
PG. PAGE
R/W RIGHT OF WAY

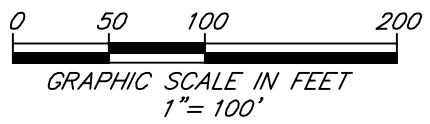

ETM
Surveying & Mapping, Inc.
VISION • EXPERIENCE • RESULTS

14775 Old St. Augustine Road, Jacksonville, FL. 32258
Tel: (904) 642-8550 Fax: (904) 642-4165
Certificate of Authorization No.: LB 3624

THIS ITEM HAS BEEN ELECTRONICALLY SIGNED AND SEALED
USING A DIGITAL SIGNATURE. PRINTED COPIES OF THIS
DOCUMENT ARE NOT CONSIDERED SIGNED AND SEALED AND THE
SIGNATURE MUST BE VERIFIED ON ANY ELECTRONIC COPIES.

SCALE: 1"=100'
DATE: OCTOBER 26, 2023
BOB L. PITTMAN
PROFESSIONAL SURVEYOR AND MAPPER
STATE OF FLORIDA PSM No. 4827

GENERAL NOTES:
1) THIS IS NOT A SURVEY.
2) BEARINGS BASED ON THE WESTERLY LINE OF RICHMOND PLACE AS BEING SOUTH 07°56'11" EAST.

EXHIBIT 14

October 26, 2023

Work Order No. 22-164.04
File No. 128H-20.04D

CDD Transfer Parcel 4

A portion of Section 34, Township 2 South, Range 28 East, Duval County, Florida, being a portion of Parcel A, as described and recorded in Official Records Book 16339, page 1146, of the current Public Records of said county, being more particularly described as follows:

For a Point of Reference, commence at the Westerly corner of the Southerly terminus of Tamaya Boulevard, a variable width right of way, as depicted on Tamaya Boulevard Phase 1, recorded in Plat Book 70, pages 37 through 42, of said current Public Records, said corner lying on the Northerly right of way line of Beach Boulevard (U.S. Highway No. 90) (State Road No. 212), a 200 foot right of way as presently established; thence South $89^{\circ}30'13''$ West, along said Northerly right of way line, 23.54 feet to the Southwesterly corner of those lands described and recorded in Official Records Book 14868, page 1172, of said current Public Records and the Point of Beginning.

From said Point of Beginning, thence continue South $89^{\circ}30'13''$ West, along said Northerly right of way line, 176.24 feet to a point lying on the boundary line of those lands described and recorded in Official Records Book 20015, page 1227, of said current Public Records; thence along said boundary line the following 4 courses: Course 1, thence North $00^{\circ}31'50''$ West, departing said Northerly right of way line, 49.57 feet; Course 2, thence Due East, 156.32 feet; Course 3, thence North $00^{\circ}03'12''$ East, 180.58 feet; Course 4, thence North $88^{\circ}43'46''$ East, 41.95 feet to a point lying on the Westerly right of way line of said Tamaya Boulevard; thence South $00^{\circ}26'58''$ East, departing said boundary line and along said Westerly right of way line, 29.35 feet to the Northeasterly corner of those lands described and recorded in said Official Records Book 14868, page 1172; thence South $89^{\circ}30'13''$ West, departing said Westerly right of way line and along the boundary line of last said lands, 23.60 feet; thence South $00^{\circ}28'01''$ East, continuing along said boundary line, 200.00 feet to the Point of Beginning.

Containing 12,755 square feet, more or less.

SKETCH TO ACCOMPANY DESCRIPTION OF

A PORTION OF SECTION 34, TOWNSHIP 2 SOUTH, RANGE 28 EAST, DUVAL COUNTY, FLORIDA, BEING A PORTION OF PARCEL A, AS DESCRIBED AND RECORDED IN OFFICIAL RECORDS BOOK 16339, PAGE 1146, OF THE CURRENT PUBLIC RECORDS OF SAID COUNTY, BEING MORE PARTICULARLY DESCRIBED IN SEPARATE ATTACHMENT.

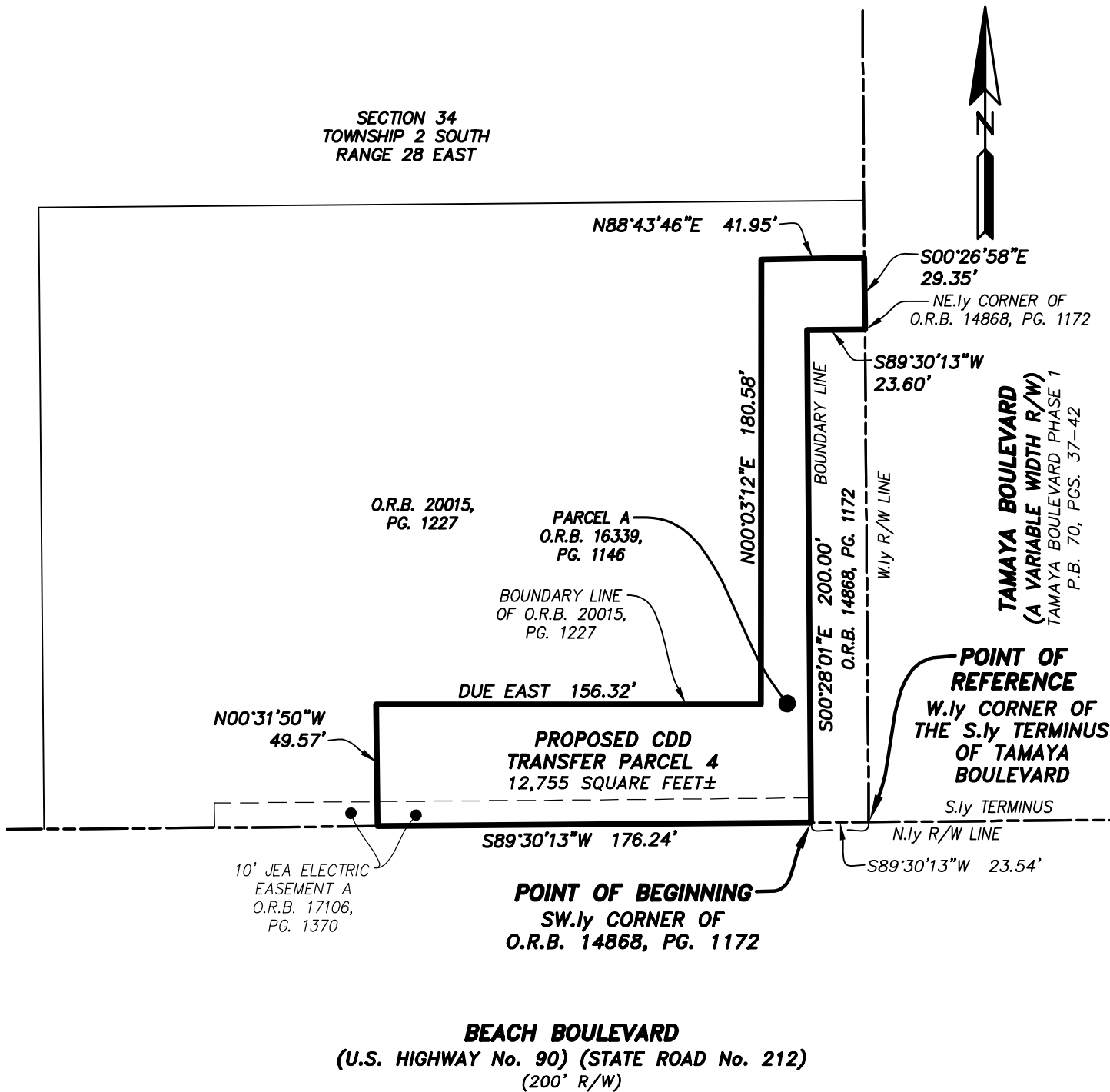

LEGEND:

P.B. PLAT BOOK
O.R.B. OFFICIAL RECORDS BOOK
PG. PAGE
R/W RIGHT OF WAY

GENERAL NOTES:

- 1) THIS IS NOT A SURVEY.
- 2) BEARINGS BASED ON THE NORTHERLY RIGHT OF WAY LINE OF BEACH BOULEVARD AS BEING SOUTH 89°30'13" WEST.

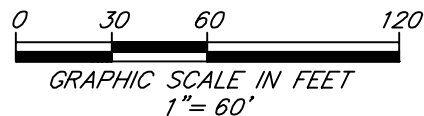

ETM
Surveying & Mapping, Inc.
VISION • EXPERIENCE • RESULTS

14775 Old St. Augustine Road, Jacksonville, FL. 32258
Tel: (904) 642-8550 Fax: (904) 642-4165
Certificate of Authorization No.: LB 3624

SCALE: 1"=60'
DATE: OCTOBER 26, 2023

BOB L. PITTMAN
PROFESSIONAL SURVEYOR AND MAPPER
STATE of FLORIDA PSM No. 4827

THIS ITEM HAS BEEN ELECTRONICALLY SIGNED AND SEALED USING A DIGITAL SIGNATURE. PRINTED COPIES OF THIS DOCUMENT ARE NOT CONSIDERED SIGNED AND SEALED AND THE SIGNATURE MUST BE VERIFIED ON ANY ELECTRONIC COPIES.

EXHIBIT 15

October 26, 2023

Work Order No. 22-164.04
File No. 128H-20.04E

CDD Transfer Parcel 5

A portion of Section 34, Township 2 South, Range 28 East, Duval County, Florida, being a portion of Parcel A, as described and recorded in Official Records Book 16339, page 1146, of the current Public Records of said county, being more particularly described as follows:

For a Point of Reference, commence at the Northeasterly corner of Redhawk Village, as recorded in Plat Book 73, pages 112 through 122, of said current Public Records, said corner lying on the Westerly right of way line of Tamaya Boulevard, a variable width right of way as presently established; thence Northerly along said Westerly right of way line the following 4 courses: Course 1, thence North $12^{\circ}47'05''$ East, 110.99 feet; Course 2, thence North $77^{\circ}12'55''$ West, 4.50 feet; Course 3, thence North $12^{\circ}47'05''$ East, 62.75 feet to the point of curvature of a curve concave Westerly having a radius of 599.00 feet; Course 4, thence Northerly along the arc of said curve, through a central angle of $12^{\circ}24'02''$, an arc length of 129.64 feet to a point lying on the boundary line of those lands described and recorded in Official Records Book 17503, page 2316, of said current Public Records and the Point of Beginning, said arc being subtended by a chord bearing and distance of North $06^{\circ}35'04''$ East, 129.39 feet.

From said Point of Beginning, thence along said boundary line the following 5 courses: Course 1, thence South $89^{\circ}03'04''$ West, departing said Westerly right of way line and along a non-tangent line, 20.01 feet to a point on a non-tangent curve concave Westerly having a radius of 579.00 feet; Course 2, thence Northerly along the arc of said curve, through a central angle of $09^{\circ}57'22''$, an arc length of 100.61 feet to a point on said curve, said arc being subtended by a chord bearing and distance of North $04^{\circ}32'52''$ West, 100.49 feet; Course 3, thence Northerly along the arc of a non-tangent curve concave Easterly having a radius of 131.79 feet, through a central angle of $77^{\circ}36'33''$, an arc length of 178.52 feet to a point on said curve, said arc being subtended by a chord bearing and distance of North $17^{\circ}43'36''$ West, 165.18 feet; Course 4, thence Northwesterly along the arc of a non-tangent curve concave Southwesterly having a radius of 579.00 feet, through a central angle of $09^{\circ}45'46''$, an arc length of 98.66 feet to a point on said curve, said arc being subtended by a chord bearing and distance of North $30^{\circ}48'33''$ West, 98.54 feet; Course 5, thence North $54^{\circ}56'12''$ East, along a non-tangent line, 20.00 feet to a point lying on said Westerly right of way line of Tamaya Boulevard; thence Southerly departing said boundary line, along said Westerly right of way line, and along the arc of a non-tangent curve concave Westerly having a radius of 599.00 feet, through a central angle of $36^{\circ}03'14''$, an arc length of 376.93 feet to the Point of Beginning, said arc being subtended by a chord bearing and distance of South $17^{\circ}38'34''$ East, 370.74 feet.

Containing 11,354 square feet, more or less.

**SKETCH TO ACCOMPANY DESCRIPTION OF
A PORTION OF SECTION 34, TOWNSHIP 2 SOUTH, RANGE 28 EAST,
DUVAL COUNTY, FLORIDA, BEING A PORTION OF PARCEL A,
AS DESCRIBED AND RECORDED IN OFFICIAL RECORDS BOOK 16339,
PAGE 1146, OF THE CURRENT PUBLIC RECORDS OF SAID COUNTY,
BEING MORE PARTICULARLY DESCRIBED IN SEPARATE ATTACHMENT.**

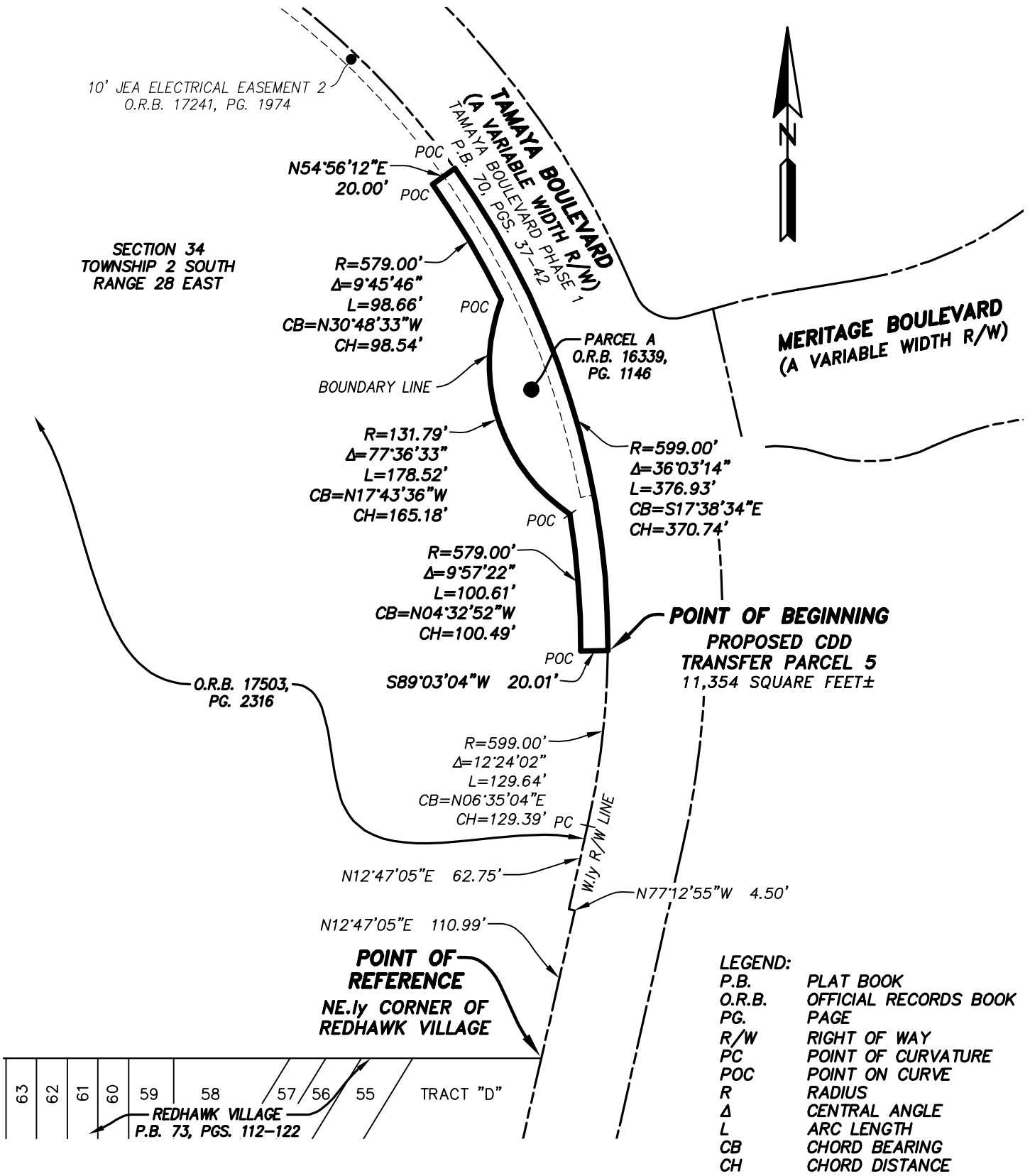

ETM
Surveying & Mapping, Inc.
VISION • EXPERIENCE • RESULTS

14775 Old St. Augustine Road, Jacksonville, FL 32258
Tel: (904) 642-8550 Fax: (904) 642-4165
Certificate of Authorization No.: LB 3624

SCALE: 1"=100'
DATE: OCTOBER 26, 2023

BOB L. PITTMAN
PROFESSIONAL SURVEYOR AND MAPPER
STATE of FLORIDA PSM No. 4827

EXHIBIT 16

This instrument was prepared by:
J. Andrew Hagan, Esquire
2379 Beville Road
Daytona Beach, Florida 32119

Parcel ID# 165284-6050, 167067-0475

QUIT CLAIM DEED

THIS QUIT CLAIM DEED is made and entered into as of this _____ day of _____, 2023, by TAMAYA LOAN ACQUISITION, LLC, a Florida limited liability company, whose address is 2379 Beville Road, Daytona Beach, Florida 32119 (hereinafter called the "Grantor"), to BEACH COMMUNITY DEVELOPMENT DISTRICT, a local unit of special purpose government organized and existing in accordance with Chapter 190, Florida Statutes, whose address is c/o Vesta District Services, 250 International Pkwy, Ste. 208, Lake Mary, Florida 32746 (hereinafter called the "Grantee").

W I T N E S S E T H:

That the Grantor, for and in consideration of the sum of Ten and No/100 Dollars (\$10.00) and other valuable consideration, receipt whereof is hereby acknowledged, by these presents does hereby remise, release and quitclaims unto the said Grantee forever, al the right, title interest, claim and demand which the said Grantor has in and to the following described land, situate, lying and being in the County of Duval, State of Florida, to wit:

See attached Exhibit "A" Legal Description

TO HAVE AND TO HOLD the same together with all and singular the appurtenances thereunto belonging or in anywise appertaining, in all the estate, right, title, interest, lien, equity and claim whatsoever of the said Grantor, either in law or in equity, to the only proper use, benefit and behoof of the said Grantee forever.

IN WITNESS WHEREOF, the Grantor has signed and sealed these presents the day and year first above written.

Signed, sealed and delivered in the presence of:

TAMAYA LOAN ACQUISITION, LLC,
a Florida limited liability company

Witness Signature

By: _____
Morteza Hosseini-Kargar, President

Witness Printed Name

Witness Signature

Witness Printed Name

**STATE OF FLORIDA
COUNTY OF VOLUSIA**

The foregoing instrument was acknowledged before me by means of personal appearance on this ____ day of _____, 2023, by Morteza Hosseini-Kargar, President of TAMAYA LOAN ACQUISITION, LLC, a Florida limited liability company, () who is personally known to me or () who produced _____ as identification and who executed on behalf of the corporation.

Notary Public State of Florida
My Commission Expires:

(SEAL)

EXHIBIT "A"
LEGAL DESCRIPTION

October 10, 2023
Page 1 of 2

Work Order No. 22-164.03
File No. 128H-20.03A

CDD Transfer Parcel 1

A portion of Section 34, Township 2 South, Range 28 East, Duval County, Florida, being a portion of Parcel A, as described and recorded in Official Records Book 16339, page 1146, of the current Public Records of said county, being more particularly described as follows:

For a Point of Beginning, commence at the Southwesterly corner of Liv at Tamaya, as recorded in Plat Book 80, pages 79 through 95, of said current Public Records, said corner lying on the Northerly right of way line of Beach Boulevard (U.S. Highway No. 90) (State Road No. 212), a 200 foot right of way as presently established; thence South $89^{\circ}30'13''$ West, along said Northerly right of way line, 412.08 feet to the Southeasterly corner of those lands described and recorded in Official Records Book 14868, page 1172, of said current Public Records; thence North $00^{\circ}30'02''$ West, departing said Northerly right of way line and along the boundary line of last said lands, 200.00 feet; thence South $89^{\circ}30'13''$ West, continuing along said boundary line, 34.18 feet to the Northwesterly corner thereof, said corner lying on the Easterly right of way line of Tamaya Boulevard, a variable width right of way as presently established; thence North $00^{\circ}26'58''$ West, departing said boundary line and along said Easterly right of way line, 215.27 feet to the Southwesterly corner of those lands described and recorded in Official Records Book 14999, page 470, of said current Public Records; thence along the boundary line of last said lands the following 10 courses: Course 1, thence Due East, departing said Easterly right of way line, 33.86 feet; Course 2, thence North $89^{\circ}59'53''$ East, 121.68 feet to the point of curvature of a curve concave Northwesterly having a radius of 51.50 feet; Course 3, thence Northeasterly along the arc of said curve, through a central angle of $89^{\circ}59'53''$, an arc length of 80.89 feet to the point of tangency of said curve, said arc being subtended by a chord bearing and distance of North $44^{\circ}59'56''$ East, 72.83 feet; Course 4, thence Due North, 209.02 feet; Course 5, thence North $03^{\circ}32'23''$ East, 28.99 feet; Course 6, thence North $14^{\circ}58'32''$ West, 44.10 feet; Course 7, thence North $73^{\circ}30'09''$ West, 37.61 feet; Course 8, thence North $46^{\circ}04'25''$ West, 80.24 feet; Course 9, thence North $62^{\circ}26'52''$ West, 42.68 feet; Course 10, thence South $89^{\circ}33'02''$ West, 69.02 feet to the Northwesterly corner thereof, said corner lying on said Easterly right of way line of Tamaya Boulevard; thence along said Easterly right of way line the following 8 courses: Course 1, thence North $00^{\circ}26'58''$ West, departing said boundary line, 186.12 feet to the point of curvature of a curve concave Easterly having a radius of 2230.00 feet; Course 2, thence Northerly along the arc of said curve, through a central angle of $13^{\circ}14'03''$, an arc length of 515.09 feet to the point of tangency of said curve, said arc being subtended by a chord bearing and distance of North $06^{\circ}10'04''$ East, 513.94 feet; Course 3, thence North $12^{\circ}47'05''$ East, 444.45 feet to the point of curvature of a curve concave Westerly having a radius of 670.50 feet; Course 4, thence Northerly along the arc of said curve, through a

CDD Transfer Parcel 1 (continued)

central angle of $10^{\circ}43'04''$, an arc length of 125.43 feet to a point on said curve, said arc being subtended by a chord bearing and distance of North $07^{\circ}25'33''$ East, 125.24 feet; Course 5, thence North $14^{\circ}41'37''$ East, along a non-tangent line, 51.72 feet to a point on a non-tangent curve concave Westerly having a radius of 679.50 feet; Course 6, thence Northerly along the arc of said curve, through a central angle of $07^{\circ}05'00''$, an arc length of 84.00 feet to a point of reverse curvature, said arc being subtended by a chord bearing and distance of North $04^{\circ}24'06''$ West, 83.95 feet; Course 7, thence Northeasterly along the arc of a curve concave Southeasterly having a radius of 30.00 feet, through a central angle of $84^{\circ}03'59''$, an arc length of 44.02 feet to a point of compound curvature, said point being the Southerly corner of the Westerly terminus of Meritage Boulevard, a variable width right of way, as depicted on Bella Nina at Tamaya Phase 2, recorded in Plat Book 69, pages 27 through 32, of said current Public Records, said arc being subtended by a chord bearing and distance of North $34^{\circ}05'24''$ East, 40.17 feet; thence Easterly along the Southerly right of way line of said Meritage Boulevard the following 3 courses: Course 1, thence Easterly along the arc of a curve concave Southerly having a radius of 100.00 feet, through a central angle of $32^{\circ}37'30''$, an arc length of 56.94 feet to a point of reverse curvature, said arc being subtended by a chord bearing and distance of South $87^{\circ}33'52''$ East, 56.18 feet; Course 2, thence Easterly along the arc of a curve concave Northerly having a radius of 108.00 feet, through a central angle of $44^{\circ}50'09''$, an arc length of 84.51 feet to a point of reverse curvature, said arc being subtended by a chord bearing and distance of North $86^{\circ}19'49''$ East, 82.37 feet; Course 3, thence Easterly along the arc of a curve concave Southerly having a radius of 207.00 feet, through a central angle of $22^{\circ}31'03''$, an arc length of 81.35 feet to a point on said curve, said point being the Northwesterly corner of said Liv at Tamaya, said arc being subtended by a chord bearing and distance of North $75^{\circ}10'16''$ East, 80.83 feet; thence along the Westerly line of said Liv at Tamaya the following 3 courses: Course 1, thence Due South, departing said Southerly right of way line and along a non-tangent line, 746.46 feet; Course 2, thence South $06^{\circ}23'49''$ East, 350.00 feet; Course 3, thence Due South, 1180.00 feet to the Point of Beginning.

Containing 18.24 acres, more or less.

SKETCH TO ACCOMPANY DESCRIPTION OF
A PORTION OF SECTION 34, TOWNSHIP 2 SOUTH, RANGE 28 EAST,
DUVAL COUNTY, FLORIDA, BEING A PORTION OF PARCEL A,
AS DESCRIBED AND RECORDED IN OFFICIAL RECORDS BOOK 16339,
PAGE 1146, OF THE CURRENT PUBLIC RECORDS OF SAID COUNTY,
BEING MORE PARTICULARLY DESCRIBED IN SEPARATE ATTACHMENT.

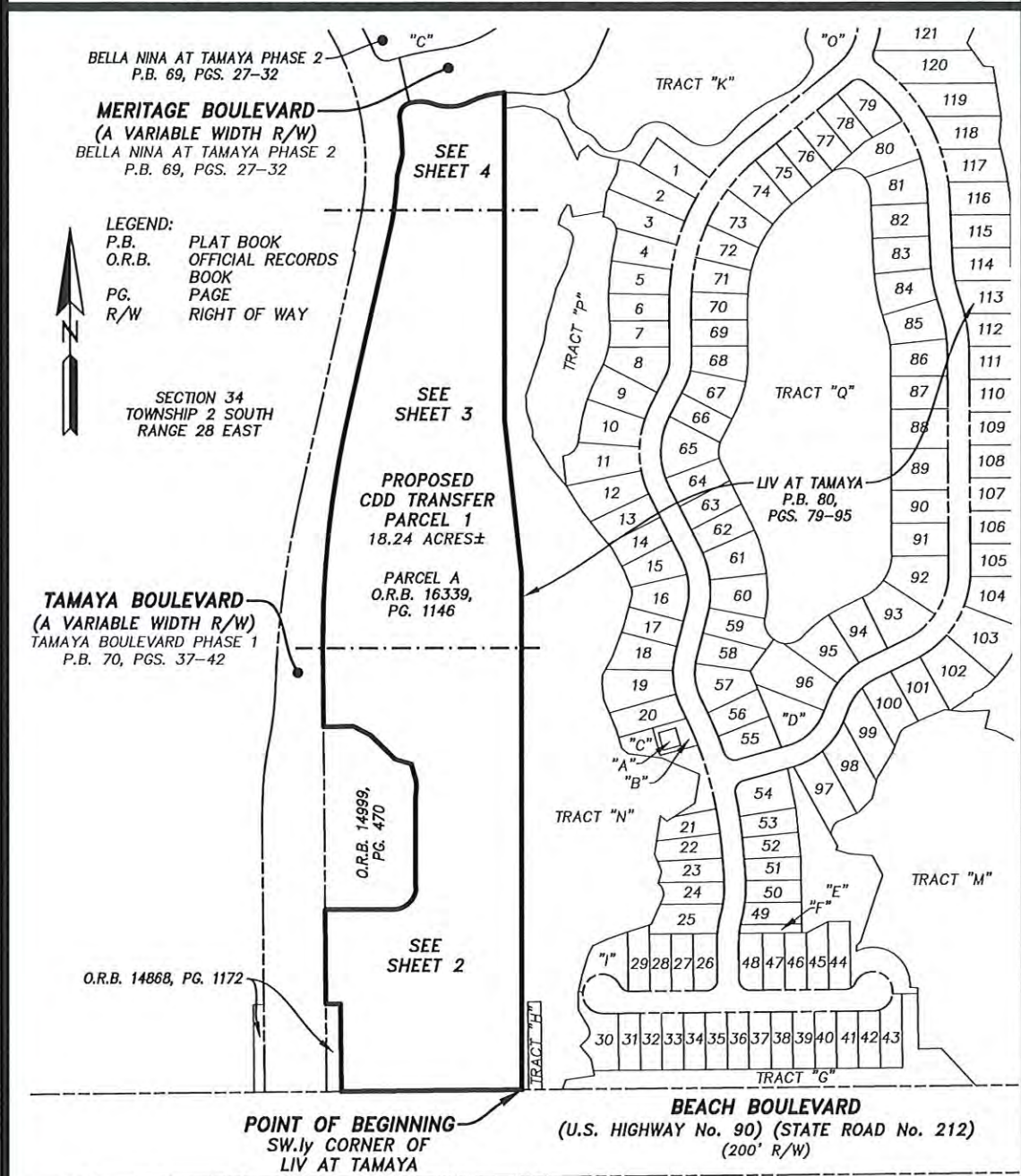

SHEET 1 OF 4

GENERAL NOTES:

- 1) THIS IS NOT A SURVEY.
- 2) BEARINGS BASED ON THE NORTHERLY RIGHT OF WAY LINE OF BEACH BOULEVARD AS BEING SOUTH 89°30'13" WEST.

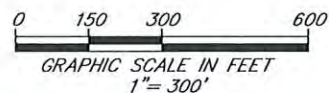

ETM
Surveying & Mapping, Inc.
VISION • EXPERIENCE • RESULTS

14775 Old St. Augustine Road, Jacksonville, FL. 32258
 Tel: (904) 642-8550 Fax: (904) 642-4165
 Certificate of Authorization No.: LB 3624

THIS ITEM HAS BEEN ELECTRONICALLY SIGNED AND SEALED USING A DIGITAL SIGNATURE. PRINTED COPIES OF THIS DOCUMENT ARE NOT CONSIDERED SIGNED AND SEALED AND THE SIGNATURE MUST BE VERIFIED ON ANY ELECTRONIC COPIES.



Digital Signature
 by: Bob L.
 Pittman, P.S.M.

SCALE: 1"=300'

DATE: OCTOBER 10, 2023

BOB L. PITTMAN
 PROFESSIONAL SURVEYOR AND MAPPER
 STATE OF FLORIDA PSM No. 4827

A PORTION OF SECTION 34, TOWNSHIP 2 SOUTH, RANGE 28 EAST,
 DUVAL COUNTY, FLORIDA, BEING A PORTION OF PARCEL A,
 AS DESCRIBED AND RECORDED IN OFFICIAL RECORDS BOOK 16339,
 PAGE 1146, OF THE CURRENT PUBLIC RECORDS OF SAID COUNTY.

MATCHLINE SEE SHEET 3

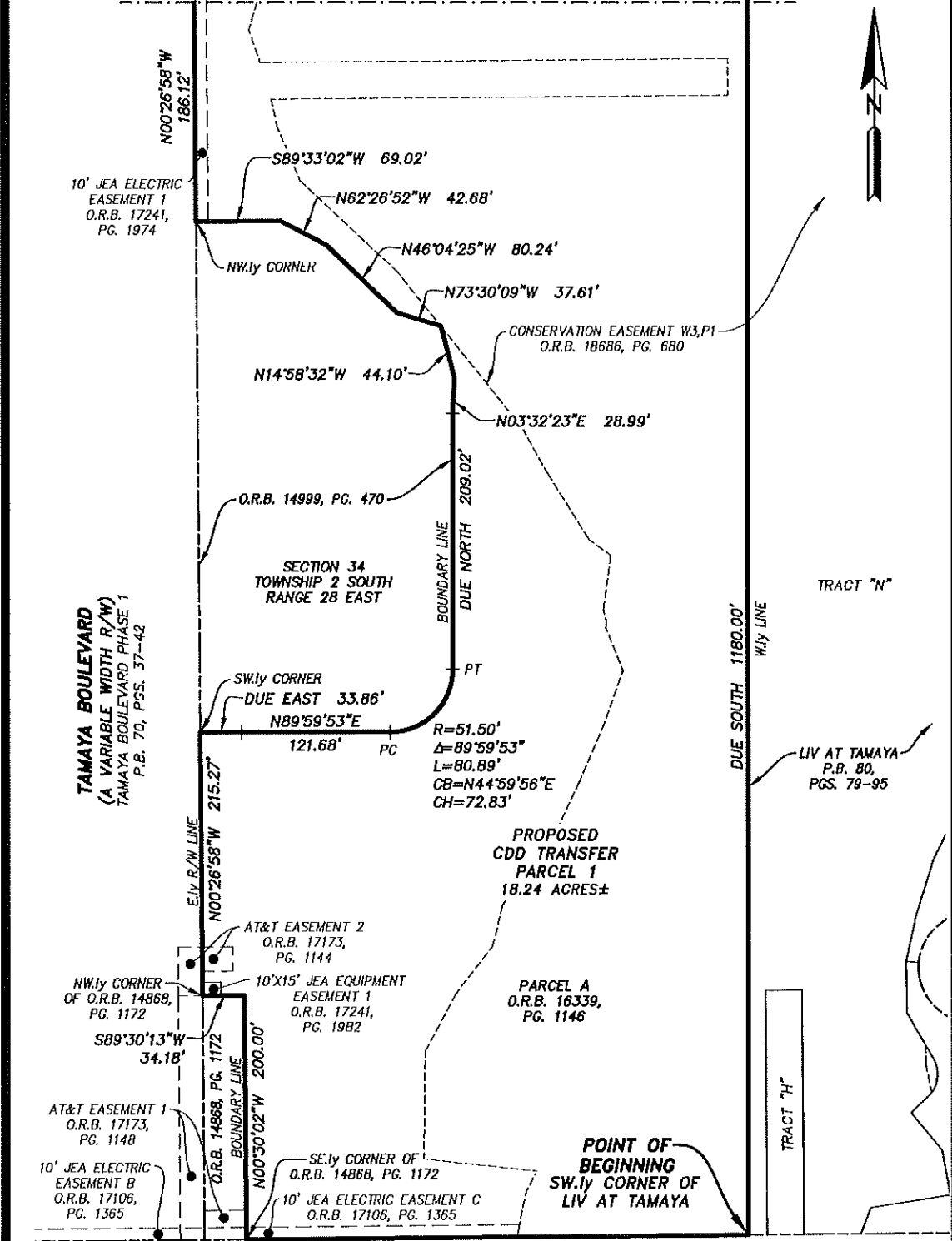

TAMAYA BOULEVARD
 (A VARIABLE WIDTH R/W)
 TAMAYA BOULEVARD PHASE 1
 P.B. 70, PGS. 37-42

NW CORNER
 OF O.R.B. 14868,
 PG. 1172

AT&T EASEMENT 1
 O.R.B. 17173,
 PG. 1148

10' JEA ELECTRIC
 EASEMENT B
 O.R.B. 17106,
 PG. 1365

SECTION 34
 TOWNSHIP 2 SOUTH
 RANGE 28 EAST

PROPOSED
 CDD TRANSFER
 PARCEL 1
 18.24 ACRES±

PARCEL A
 O.R.B. 16339,
 PG. 1146

POINT OF
 BEGINNING
 SW CORNER OF
 LIV AT TAMAYA

BEACH BOULEVARD
 (U.S. HIGHWAY No. 90)
 (STATE ROAD No. 212)
 (200' R/W)

SHEET 2 OF 4
 SEE SHEET 1 FOR GENERAL NOTES.

PREPARED BY:
ETM SURVEYING & MAPPING, INC.
 14775 OLD ST. AUGUSTINE ROAD
 JACKSONVILLE, FL 32258 (904) 842-8550
 CERTIFICATE OF AUTHORIZATION NO. LB 3624

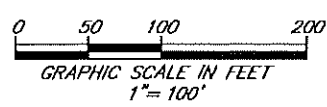

- LEGEND:**
- P.B. PLAT BOOK
 - O.R.B. OFFICIAL RECORDS BOOK
 - O.R.V. OFFICIAL RECORDS VOLUME
 - PG. PAGE
 - R/W RIGHT OF WAY
 - PC POINT OF CURVATURE
 - PT POINT OF TANGENCY
 - R RADIUS
 - Δ CENTRAL ANGLE
 - L ARC LENGTH
 - CB CHORD BEARING
 - CH CHORD DISTANCE

A PORTION OF SECTION 34, TOWNSHIP 2 SOUTH, RANGE 28 EAST,
 DUVAL COUNTY, FLORIDA, BEING A PORTION OF PARCEL A,
 AS DESCRIBED AND RECORDED IN OFFICIAL RECORDS BOOK 16339,
 PAGE 1146, OF THE CURRENT PUBLIC RECORDS OF SAID COUNTY.

MATCHLINE SEE SHEET 4

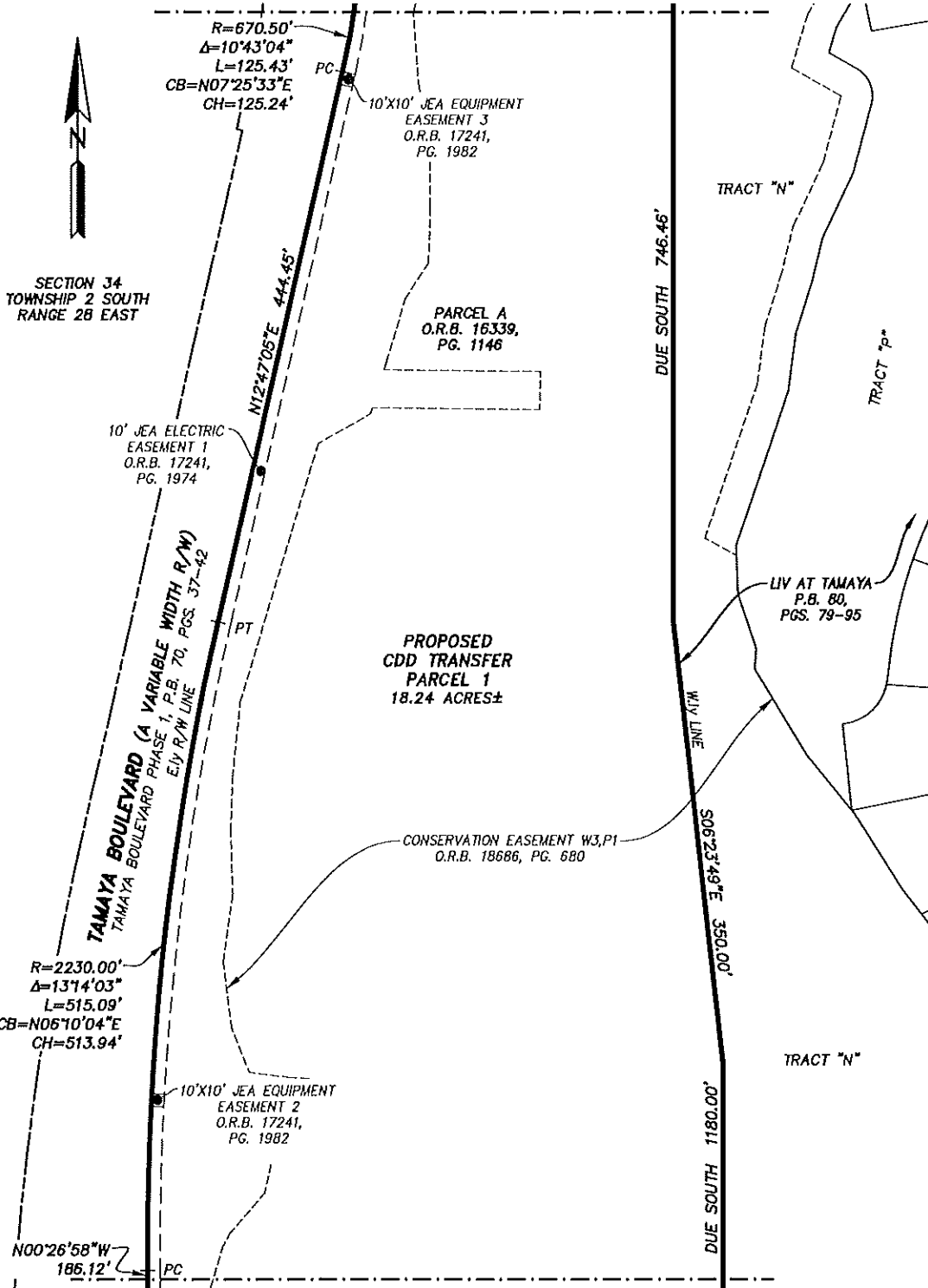

MATCHLINE SEE SHEET 2

- LEGEND:
- P.B. PLAT BOOK
 - O.R.B. OFFICIAL RECORDS BOOK
 - PG. PAGE
 - R/W RIGHT OF WAY
 - PC POINT OF CURVATURE
 - PT POINT OF TANGENCY
 - R RADIUS
 - Δ CENTRAL ANGLE
 - L ARC LENGTH
 - CB CHORD BEARING
 - CH CHORD DISTANCE

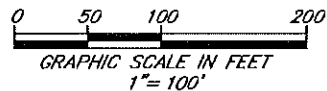

PREPARED BY:
 ETM SURVEYING & MAPPING, INC.
 14775 OLD ST. AUGUSTINE ROAD
 JACKSONVILLE, FL 32258 (904) 642-8550
 CERTIFICATE OF AUTHORIZATION NO. LB 3624

SHEET 3 OF 4
 SEE SHEET 1 FOR GENERAL NOTES.

A PORTION OF SECTION 34, TOWNSHIP 2 SOUTH, RANGE 28 EAST,
 DUVAL COUNTY, FLORIDA, BEING A PORTION OF PARCEL A,
 AS DESCRIBED AND RECORDED IN OFFICIAL RECORDS BOOK 16339,
 PAGE 1146, OF THE CURRENT PUBLIC RECORDS OF SAID COUNTY.

CURVE TABLE					
CURVE	RADIUS	CENTRAL ANGLE	ARC LENGTH	CHORD BEARING	CHORD DISTANCE
C1	670.50'	10°43'04"	125.43'	N07°25'33"E	125.24'
C2	679.50'	7°05'00"	84.00'	N04°24'06"W	83.95'
C3	30.00'	84°03'59"	44.02'	N34°05'24"E	40.17'
C4	100.00'	32°37'30"	56.94'	S87°33'52"E	56.18'
C5	108.00'	44°50'09"	84.51'	N86°19'49"E	82.37'
C6	207.00'	22°31'03"	81.35'	N75°10'16"E	80.83'

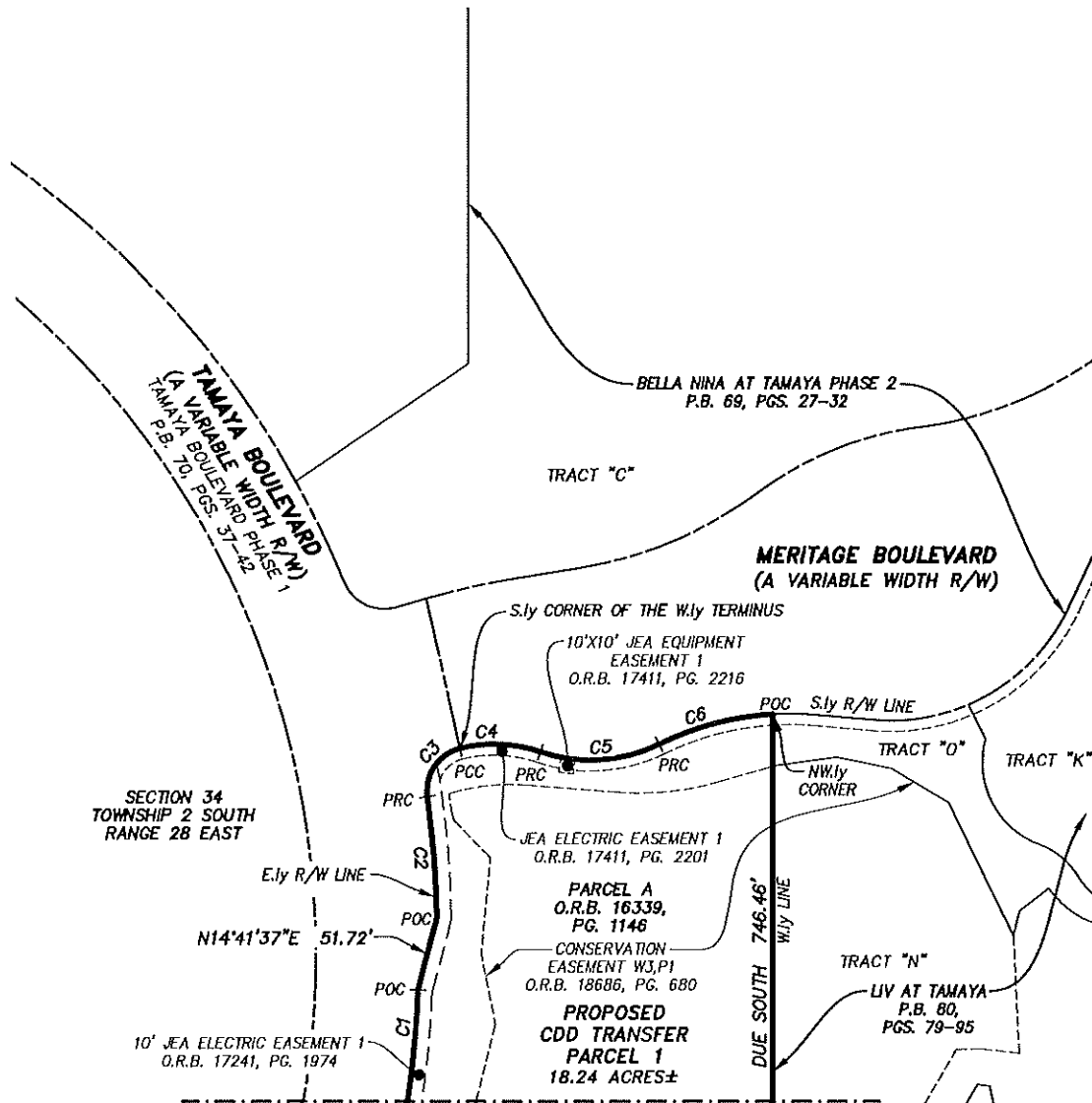
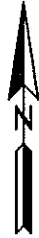

- LEGEND:**
- P.B. PLAT BOOK
 - O.R.B. OFFICIAL RECORDS BOOK
 - PG. PAGE
 - R/W RIGHT OF WAY
 - POC POINT ON CURVE
 - PRC POINT OF REVERSE CURVATURE
 - PCC POINT OF COMPOUND CURVATURE
 - C1 TABULATED CURVE DATA

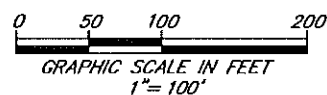

SHEET 4 OF 4
 SEE SHEET 1 FOR GENERAL NOTES.

PREPARED BY:
ETM SURVEYING & MAPPING, INC.
 14775 OLD ST. AUGUSTINE ROAD
 JACKSONVILLE, FL 32258 (904) 642-8550
 CERTIFICATE OF AUTHORIZATION NO. LB 3624

October 10, 2023

Work Order No. 22-164.03

File No. 128H-20.03B

CDD Transfer Parcel 2

A portion of Section 34, Township 2 South, Range 28 East, Duval County, Florida, being a portion of Parcel A, as described and recorded in Official Records Book 16339, page 1146, of the current Public Records of said county, being more particularly described as follows:

For a Point of Beginning, commence at the Northwesterly corner of Bella Nina at Tamaya Phase 2, as recorded in Plat Book 69, pages 27 through 32, of said current Public Records; thence Due South, along the Westerly line of said Bella Nina at Tamaya Phase 2, a distance of 278.41 feet; thence South $55^{\circ}55'16''$ West, continuing along said Westerly line, 145.00 feet to the Westerly corner thereof, said corner lying on the Northerly right of way line of Tamaya Boulevard, a variable width right of way as presently established; thence Northwesterly along said Northerly right of way line the following 4 courses: Course 1, thence Northwesterly, departing said Westerly line and along the arc of a non-tangent curve concave Southwesterly having a radius of 670.50 feet, through a central angle of $60^{\circ}52'44''$, an arc length of 712.43 feet to the point of tangency of said curve, said arc being subtended by a chord bearing and distance of North $59^{\circ}41'12''$ West, 679.39 feet; Course 2, thence South $89^{\circ}52'26''$ West, 451.88 feet to the point of curvature of a curve concave Northerly having a radius of 300.00 feet; Course 3, thence Westerly along the arc of said curve, through a central angle of $18^{\circ}12'25''$, an arc length of 95.33 feet to a point of reverse curvature, said arc being subtended by a chord bearing and distance of North $81^{\circ}01'22''$ West, 94.93 feet; Course 4, thence Westerly along the arc of a curve concave Southerly having a radius of 300.00 feet, through a central angle of $18^{\circ}12'49''$, an arc length of 95.37 feet to a point lying on the Northerly line of said Section 34, said arc being subtended by a chord bearing and distance of North $81^{\circ}01'34''$ West, 94.97 feet; thence North $89^{\circ}52'36''$ East, departing said Northerly right of way line, along said Northerly line and along a non-tangent line, 820.66 feet to a point lying on the Westerly line of Isabella at Tamaya Phase 2, as recorded in Plat Book 76, pages 147 through 157, of said current Public Records; thence South $00^{\circ}45'10''$ East, departing said Northerly line and along said Westerly line, 14.86 feet to the Southwesterly corner thereof; thence North $89^{\circ}52'01''$ East, along the Southerly line of last said lands, 525.19 feet to the Point of Beginning.

Containing 2.86 acres, more or less.

SKETCH TO ACCOMPANY DESCRIPTION OF

A PORTION OF SECTION 34, TOWNSHIP 2 SOUTH, RANGE 28 EAST, DUVAL COUNTY, FLORIDA, BEING A PORTION OF PARCEL A, AS DESCRIBED AND RECORDED IN OFFICIAL RECORDS BOOK 16339, PAGE 1146, OF THE CURRENT PUBLIC RECORDS OF SAID COUNTY, BEING MORE PARTICULARLY DESCRIBED IN SEPARATE ATTACHMENT.

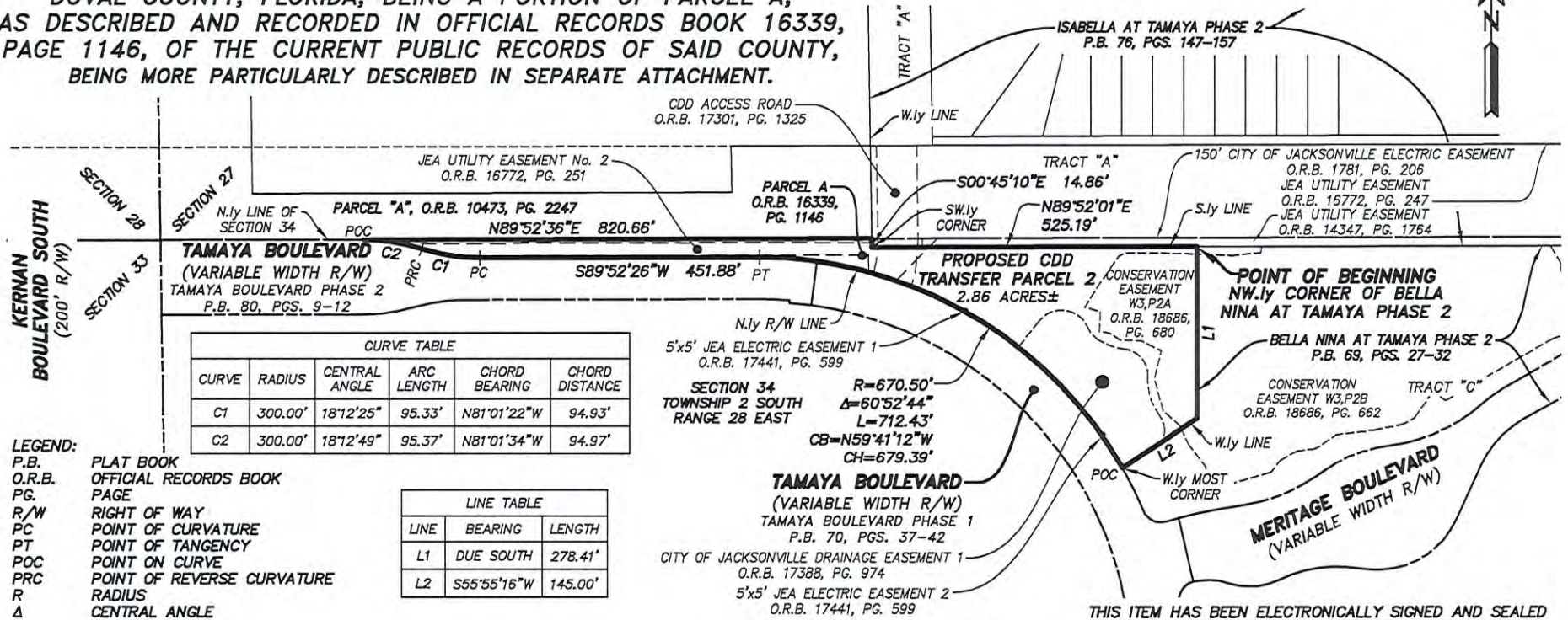

CURVE TABLE					
CURVE	RADIUS	CENTRAL ANGLE	ARC LENGTH	CHORD BEARING	CHORD DISTANCE
C1	300.00'	18°12'25"	95.33'	N81°01'22"W	94.93'
C2	300.00'	18°12'49"	95.37'	N81°01'34"W	94.97'

LINE TABLE		
LINE	BEARING	LENGTH
L1	DUE SOUTH	278.41'
L2	S55°55'16"W	145.00'

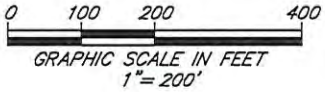

- LEGEND:**
- P.B. PLAT BOOK
 - O.R.B. OFFICIAL RECORDS BOOK
 - PG. PAGE
 - R/W RIGHT OF WAY
 - PC POINT OF CURVATURE
 - PT POINT OF TANGENCY
 - POC POINT ON CURVE
 - PRC POINT OF REVERSE CURVATURE
 - R RADIUS
 - Δ CENTRAL ANGLE
 - L ARC LENGTH
 - CB CHORD BEARING
 - CH CHORD DISTANCE
 - L1 TABULATED LINE DATA
 - C1 TABULATED CURVE DATA

GENERAL NOTES:
 1) THIS IS NOT A SURVEY.
 2) BEARINGS BASED ON THE NORTHERLY LINE OF SECTION 34 AS BEING NORTH 89°52'36" EAST.

ETM
Surveying & Mapping, Inc.
 VISION • EXPERIENCE • RESULTS

14775 Old St. Augustine Road, Jacksonville, FL 32258
 Tel: (904) 642-8550 Fax: (904) 642-4165
 Certificate of Authorization No.: LB 3624

THIS ITEM HAS BEEN ELECTRONICALLY SIGNED AND SEALED USING A DIGITAL SIGNATURE. PRINTED COPIES OF THIS DOCUMENT ARE NOT CONSIDERED SIGNED AND SEALED AND THE SIGNATURE MUST BE VERIFIED ON ANY ELECTRONIC COPIES.



Digital Signature by: Bob L. Pittman, P.S.M.

SCALE: 1"=200'
 DATE: OCTOBER 10, 2023
BOB L. PITTMAN
 PROFESSIONAL SURVEYOR AND MAPPER
 STATE OF FLORIDA PSM No. 4827

EXHIBIT 17



1702 Lindsey Rd
Jacksonville, Fl. 32221
Ph (904) 781-7060 Fax (904) 619-5011

CGC1523954 CMC1250093 CFC1428601 CCC1329086

Tamaya Beach CDD

Attn:Ron -Mgmt

10 19 23

Re:concrete sidewalk--3003 Savona Ct

All Weather Contractors is proposing the following services for the below mentioned prices. Any item not specifically mentioned is subject to a written change order.

- >saw cut and remove a 48 sq ft area of trip hazard concrete sidewalk at the unit listed above in location per management
- >cut out and remove tree roots where the concrete is removed
- >form and pour new 3000 psi concrete with a broom finish where removed to eliminate the trip hazard
- >strip the forms and clean up job and haul away debris

Total Price \$1,770.00

Proposal Signed by _____ **Printed Name** _____

Thank you for your consideration

Scott Haines -C 904.402.6561





EXHIBIT 18



1702 Lindsey Rd
Jacksonville, Fl. 32221
Ph (904) 781-7060 Fax (904) 619-5011

CGC1523954 CMC1250093 CFC1428601 CCC1329086

Tamaya Beach CDD

Attn:Ron -Mgmt

10 26 23

Re:concrete repairs

All Weather Contractors is proposing the following services for the below mentioned prices. Any item not specifically mentioned is subject to a written change order.

- >saw cut and remove the following locations per management listed below (SQ FT)
- >cut out and remove tree roots where the concrete is removed
- >form and pour new 3000 psi concrete with a broom finish where removed to eliminate the trip hazard
- >strip the forms and clean up job and haul away debris
- >any locations with (LIN FT) will be grinded down

*brettungar street

- 2914-6 lin ft
- 3110-6 lin ft
- 3122-6 lin ft
- 3128-6 lin ft
- 3146-6 lin ft

*brettungar ct

- 3098-36 sq ft
- 3074-5 lin ft
- 3068-6 lin ft
- 3056-12 lin ft
- 3050-6 lin ft
- 3038-6 lin ft
- 3032-6 lin ft

*bari ct
-2994-6 lin ft

*Savona Ct
-3063-6 lin ft
-3069-12 lin ft

*danube ct
-3036-36 sq ft
-3078-6 lin ft

*trave ct
-13016-54 sq ft

Total Price \$5,675.00

Proposal Signed by _____ **Printed Name** _____
Thank you for your consideration
Scott Haines -C 904.402.6561

EXHIBIT 19

RESOLUTION NO. 2024-03

BEACH COMMUNITY DEVELOPMENT DISTRICT IMPLEMENTING SECTION 190.006(3), FLORIDA STATUTES, AND REQUESTING THAT THE DUVAL COUNTY SUPERVISOR OF ELECTIONS CONDUCT THE DISTRICT'S GENERAL ELECTIONS; PROVIDING FOR COMPENSATION; SETTING FORTH THE TERMS OF OFFICE; AUTHORIZING NOTICE OF THE QUALIFYING PERIOD; AND PROVIDING FOR SEVERABILITY AND AN EFFECTIVE DATE.

WHEREAS, the Beach Community Development District ("**District**") is a local unit of special-purpose government created and existing pursuant to Chapter 190, *Florida Statutes*, being situated entirely within the City of Jacksonville, Duval County, Florida; and

WHEREAS, the Board of Supervisors of the District ("**Board**") seeks to implement Section 190.006(3), *Florida Statutes*, and to instruct the Duval County Supervisor of Elections ("**Supervisor**") to conduct the District's elections by the qualified electors of the District at the general election ("**General Election**").

NOW, THEREFORE, BE IT RESOLVED BY THE BOARD OF SUPERVISORS OF THE BEACH COMMUNITY DEVELOPMENT DISTRICT:

1. **GENERAL ELECTION SEATS.** Seat 1, currently held by Elena Korsakova, and Seat 3, currently held by Robert Renn are scheduled for the General Election beginning in November 2024. The District Manager is hereby authorized to notify the Supervisor of Elections as to what seats are subject to General Election for the current election year, and for each subsequent election year.

2. **QUALIFICATION PROCESS.** For each General Election, all candidates shall qualify for individual seats in accordance with Section 99.061, *Florida Statutes*, and must also be a qualified elector of the District. A qualified elector is any person at least 18 years of age who is a citizen of the United States, a legal resident of the State of Florida and of the District, and who is registered to vote with the Duval County Supervisor of Elections. Campaigns shall be conducted in accordance with Chapter 106, *Florida Statutes*.

3. **COMPENSATION.** Members of the Board receive \$200 per meeting for their attendance and no Board member shall receive more than \$4,800 per year.

4. **TERM OF OFFICE.** The term of office for the individuals to be elected to the Board in the General Election is four years. The newly elected Board members shall assume office on the second Tuesday following the election.

5. **REQUEST TO SUPERVISOR OF ELECTIONS.** The District hereby requests the Supervisor to conduct the District's General Election in November 2024, and for each subsequent General Election unless otherwise directed by the District's Manager. The District understands that it will be responsible to pay for its proportionate share of the General Election cost and agrees to pay same within a reasonable time after receipt of an invoice from the Supervisor.

6. **PUBLICATION.** The District Manager is directed to publish a notice of the qualifying period for each General Election, in a form substantially similar to **Exhibit A** attached hereto.

7. **SEVERABILITY.** The invalidity or unenforceability of any one or more provisions of this Resolution shall not affect the validity or enforceability of the remaining portions of this Resolution, or any part thereof.

8. **EFFECTIVE DATE.** This Resolution shall become effective upon its passage.

PASSED AND ADOPTED this 20 day of November 2024.

**BEACH
COMMUNITY DEVELOPMENT
DISTRICT**

CHAIRPERSON/VICE CHAIRPERSON

ATTEST:

SECRETARY/ASSISTANT SECRETARY

EXHIBIT A

**NOTICE OF QUALIFYING PERIOD FOR CANDIDATES
FOR THE BOARD OF SUPERVISORS OF THE
BEACH COMMUNITY DEVELOPMENT DISTRICT**

Notice is hereby given that the qualifying period for candidates for the office of Supervisor of the Beach Community Development District (“District”) will commence at noon on June 10, 2024, and close at noon on June 14, 2024. Candidates must qualify for the office of Supervisor with the Duval County Supervisor of Elections located at 105 East Monroe Street, Jacksonville, Florida 32202; Ph: (904) 255-8683. All candidates shall qualify for individual seats in accordance with Section 99.061, *Florida Statutes*, and must also be a “qualified elector” of the District, as defined in Section 190.003, *Florida Statutes*. A “qualified elector” is any person at least 18 years of age who is a citizen of the United States, a legal resident of the State of Florida and of the District, and who is registered to vote with the Duval County Supervisor of Elections. Campaigns shall be conducted in accordance with Chapter 106, *Florida Statutes*.

The Beach Community Development District has two (2) seats up for election, specifically seats 1 and 3. Each seat carries a four-year term of office. Elections are nonpartisan and will be held at the same time as the general election on November 5, 2024, and in the manner prescribed by law for general elections.

For additional information, please contact the Duval County Supervisor of Elections.

Publish on or before May 30, 2024.

EXHIBIT 20

Date of Action Item	Action Item	Status
	Field Operations Manager/Amenity Manager Section	
4/17/2023	FOM to visit Durbin Crossing regarding pool lanes	
7/17/2023	FOM to obtain quotes for beam over visitors entrance lane at guard house	Underway—FOM obtaining additional quotes
7/17/2023	FOM to obtain quote for shade on playground.	Underway. Initial quote provided at 9/18 meeting. Guidance provided to staff regarding future quotes including drawings; also provide financing information when doing budget for FY 2025
9/18/2023	FOM to obtain quotes to have tree stakes removed from landscaping	10/16/2023: Tabled until 11/20 meeting for better direction; FOM has begun removing stakes near Tamaya Hall as time permits.
10/16/2023	FOM to send pictures of DM of Beach Fountains when Pressure Washed	On hold pending direction at 11/20 meeting.
10/16/2023	FOM to obtain a quote for fountain repair in front of Tamaya Hall and inquire about warranty	Done--Charles Aquatics proposal in files for 11/20 meeting
10/16/2023	FOM to contact AED vendor and provide paperwork to DC for contract template	Done
10/16/2023	FOM to obtain quotes for pool lighting replacement	Underway
10/16/2023	FOM to obtain quotes for Tamaya Blvd. lighting and pictures of areas covered by quotes	Underway
10/16/2023	AM to include revenue information in Amenity Reports	Done

10/16/2023	AM to research if CPR classes can be conducted for residents	Underway
10/16/2023	AM to obtain quotes for Summer Camp	Underway
	District Manager Section	
9/18/2023	DM to set up Workshop to discuss overnight parking on roadways and vendor score cards	Done
9/18/2023	DM to check with Skye about having credit cards with "Capital One" type reward points	Underway
9/18/2023	DM to seek reimbursement from ICI for tree removed near basketball court	Underway 11/15: Letter sent
10/16/2023	DM to write to Trustee directing them to invest monies in Florida Prime to the Maximum Extent Possible	Done
10/16/2023	DM to send pictures of pressure washed fountains on Beach Blvd. to Board	On hold pending direction at 11/20 meeting.
10/16/2023	DM to send out approved letter to commercial property owners along Tamaya Boulevard (send UPS Tracking). Amend letter to include language provided by Dr. Renn	Underway 10/20: Letter sent; 10/27 and 11/15: follow ups made
10/16/2023	DM to send Board email from DC regarding ownership of trees on CDD ROW	Done
10/16/2023	DM to include monthly statements from Trustee as part of monthly financials in agenda package.	Done
	District Engineer Section	
10/16/2023	DE to provide DM with specifics for Dead End signs on specific streets	Done
	District Counsel Section	

9/18/2023	DC to provide resolution for the 10/16 meeting regarding tree removals on CDD owned ROW	Underway
10/16/2023	DC to Research the Trees Planted in CDD ROW issue and to Draft Appropriate Letters for Consideration by Board at the 11/20 Meeting	On 11/20 agenda
	Board of Supervisors Section	
10/16/2023	Board to provide DM with Stake Locations for Removal and Ron is to Provide to Tree Amigos for a Quote (per stake removal)	10/31: Email to Supervisors. One Supervisor responded by requested date of 11/7.
10/16/2023	Board to provide DM with requested locations and times for a second speed study	10/31: Email to Supervisors One Supervisor responded by requested date of 11/7.

EXHIBIT 21

BEACH CDD MEETING AGENDA MATRIX

November, 2023	Regular Meeting: 11/20	<p><i>Presentations</i></p> <p><i>Consent Agenda Items</i></p> <ul style="list-style-type: none"> • Meeting Minutes <ul style="list-style-type: none"> ▪ 10/16/2023 Regular Meeting • Unaudited Financials <ul style="list-style-type: none"> ○ September 2023—Corrected Version ○ October 2023 <p><i>Business Items</i></p> <ul style="list-style-type: none"> • Resolution regarding Removal of Trees on CDD Right of Way • Consideration of Proposal for Amenity Center Fountain Repair • Consideration of Amenity Center Fountain Replacement • Consideration to Cut Dead Tree Behind Residence on Ostia Circle • Acceptance of Parcels from Developer • Proposals for sidewalk repairs <ul style="list-style-type: none"> ▪ Savona Court ▪ First Phase • Consideration of Holiday Lighting Proposal • Resolution for 2024 General Electios <p><i>Discussions</i></p> <ul style="list-style-type: none"> • Discipline Process 	<ul style="list-style-type: none"> • Proposal from Charles Aquatics • Proposal from Lake Doctors in 10/16 agenda package • Proposal from Charles Aquatics • Site of trip and fall • Supervisor Korsakova
-----------------------	-----------------------------------	---	---

BEACH CDD MEETING AGENDA MATRIX

Staff Reports

- District Manager
 - Resident(s) Subject to Disciplinary Action
 - Incident Report Tracker
 - Action Item Report
 - Meeting Matrix
 - Memo to Board Regarding Items of Consensus from the 10/25/2023 workshop
 - Request for Clarification
 - Tree Stakes
 - Pressure Washing of Beach Blvd. Monument Fountain

- District Counsel
 - Report on Research on Tree Issue

- District Engineer

BEACH CDD MEETING AGENDA MATRIX

December, 2023

*Regular Meeting:
12/18*

Presentations

Consent Agenda Items

- Meeting Minutes
 - 11/20/2023 Regular Meeting

- Unaudited Financials (November, 2023)

Business Items

Discussions

Staff Reports

- District Manager
 - Resident(s) Subject to Disciplinary Action
 - Incident Report Tracker
 - Action Item Report
 - Meeting Matrix
- District Counsel
- District Engineer

BEACH CDD MEETING AGENDA MATRIX

<i>Unscheduled Items</i>	<p><i>Presentations</i></p> <ul style="list-style-type: none"> • Bank account presentation by Skye Lee <p><i>Consent Agenda Items</i></p> <p><i>Business Items</i></p> <p><i>Discussions (Workshop)</i></p> <ul style="list-style-type: none"> • CDD Agreement to allow HOA to enforce no parking on CDD owned streets • Overnight Parking on Roadway—Make this a violation of Amenity Policies • Vendor Scorecards • Advanced Security Issues • Placement of AED • Additional Testing of Pool Water • Agreement with City of Jacksonville for off-duty patrol of police <p><i>Staff Reports</i></p> <p><i>Public Hearing</i></p> <p><i>Vendor Reports</i></p> <ul style="list-style-type: none"> • Second speed study conducted by Jake 		<ul style="list-style-type: none"> • Could be done during a workshop • 2/7: Reply from HOA • Examples emailed to Board on 9/19 • Based on issue of indemnification, the Board tabled this matter on 7/17/2023. • Supervisor Korsakova has requested receiving the raw data
--------------------------	--	--	---

BEACH CDD MEETING AGENDA MATRIX

SUBJECT	NOTES
Safety and Security	<ul style="list-style-type: none">• Speeding in Community• Single Point of Entry/Sign-In Point for Amenities• Point of Entry for Sidewalks
Expanding Amenities	<ul style="list-style-type: none">• Facilitators
Pocket Parks	<ul style="list-style-type: none">• Beautification

BEACH CDD MEETING AGENDA MATRIX

MAJOR CONTRACT VENDOR NAME/SERVICE	EXPIRATION DATE/COMMENTS
Amenity Management/Vesta Property Services	12/13/2021-9/30/2025 (District 60 days without cause; Contractor has 90 days). First Amendment was effective on 2/7/2022.
Aquatic Management/Lake Doctors	10/1/2022-9/30/2023 (30 days)
Arbitrage Services/LLS Tax Solutions	Period ending 11/3/2023
Audit Services/DMHB	Fiscal Year ending 9/30/2024
Cintas/AED Lease-Purchase	Ending 11/2026
Criminal Background Checks/Screening One	3/15/2023-1 year auto renewal
District Counsel Services/Kutak Rock LLP	12/27/2022-
District Engineer Services/England-Thims & Miller, Inc.	9/18/2023-9/30/2024
District Management Services/DPFG (d/b/a Vesta District Services)	5/1/2022- 9/30/2023-1 year auto renewal
Fire Alarm Monitoring & Inspection/Wayne Automatic Fire Sprinklers, Inc.	10/1/2022-10/1/2023-auto renews for 1 year twice (60 days for failure to perform; 30 days without cause)
Janitorial Services—Jani-King Inc	9/27/2023-9/30/2024 – 1 year auto renewal 5 times (30 days)
Landscape Maintenance/Tree Amigos Outdoor Services, Inc.	7/1/2023-6/30/2026 (60 days for failure to perform; 30 days without cause)
Pest Control/Turner Pest Control	3/23/2017-
Security Guard Service/Advanced Security Specialist & Consulting LLC	1/21/2021- (District and Contractor 30 days without cause); First Amendment was effective on 9/28/2021; Second Amendment was effective on 10/13/2022; Third Amendment was effective on 3/5/2023
Towing Service/ASAP Towing and Storage	12/6/2022-
Website Hosting/Campus Suite	4/1/2022-9/30/2022; 1 year auto renewal

EXHIBIT 22

Beach Community Development District

Vesta District Services
250 International Parkway, Suite 208
Lake Mary, FL 32746
Phone: 321-263-0132

MEMORANDUM

TO: Board of Supervisors,
Beach Community Development District

FROM: David C. McInnes, District Manager

DATE: October 26, 2023

RE: Recommendations from the 10/25/2023 Workshop

The Board of Supervisors held a workshop on October 25, 2023. Three Supervisors were in attendance: Vice Chair Renn and Supervisors Korsakova and Papelbon.

The three participants recommend to the full Board of Supervisors that:

- Post Orders to be written for use at the Guard House
- Advance Security document residents not using TekControl. That information will be provided to the District Manager and an educational email will be sent to the resident regarding the system.
- The District Counsel work with the POA Attorney to see if an agreement can be reached regarding an MOU concerning on-street overnight parking restrictions. Additionally, the District Counsel be directed to research and determine if roads were permitted with parking restriction. If so, then amenity policies be amended to address the on-street overnight parking issue.
- The DM be directed to contact vendors and request that they submit what they recommend a scorecard look like regarding their service
- An E-Blast be sent to the residents when the AED is purchased and installed with links to videos providing instruction on use
- Consideration be given to an amendment to the amenity contract which allows for different chemical parameters than those required under FAC.
- Consideration be given to scheduling 4 to 12 workshops per year
- An E-Blast be sent to residents stating that trees located on CDD Right-of-Way not be cut